

EXHIBIT A

(12) **United States Patent**
Rogers et al.

(10) **Patent No.:** **US 8,206,514 B2**
 (45) **Date of Patent:** ***Jun. 26, 2012**

(54) **MEDICAL IMPLEMENT CLEANING DEVICE**

(75) Inventors: **Bobby E. Rogers**, San Diego, CA (US);
Paul Diperna, San Clemente, CA (US)

(73) Assignee: **Ivera Medical Corporation**, San Diego, CA (US)

(*) Notice: Subject to any disclaimer, the term of this patent is extended or adjusted under 35 U.S.C. 154(b) by 0 days.

This patent is subject to a terminal disclaimer.

(21) Appl. No.: **13/189,457**

(22) Filed: **Jul. 22, 2011**

(65) **Prior Publication Data**

US 2011/0277788 A1 Nov. 17, 2011

Related U.S. Application Data

(63) Continuation of application No. 12/860,825, filed on Aug. 20, 2010, now Pat. No. 7,985,302, which is a continuation of application No. 11/705,805, filed on Feb. 12, 2007, now Pat. No. 7,780,794.

(60) Provisional application No. 60/850,438, filed on Oct. 10, 2006, provisional application No. 60/832,437, filed on Jul. 21, 2006.

(51) **Int. Cl.**

B08B 3/04 (2006.01)
B08B 11/00 (2006.01)
B08B 1/00 (2006.01)

(52) **U.S. Cl.** **134/115 R**; 134/201; 15/97.1; 15/104.92; 15/104.93; 604/267; 604/533

(58) **Field of Classification Search** 134/6, 115 R; 15/97.1, 104.92, 104.93, 104.94; 604/267, 604/533

See application file for complete search history.

(56) **References Cited**

U.S. PATENT DOCUMENTS

4,440,207 A	4/1984	Genatempo et al.
4,778,447 A	10/1988	Velde et al.
5,554,135 A	9/1996	Menyhay
5,954,957 A	9/1999	Chin-Loy et al.
7,922,701 B2	4/2011	Buchman
2004/0258560 A1	12/2004	Lake et al.
2005/0147524 A1	7/2005	Bousquet
2007/0112333 A1	5/2007	Hoang et al.

OTHER PUBLICATIONS

Image File History for Re-examination Control No. 90/009,950, Dated Feb. 24, 2012.

Image File History for Re-examination Control No. 90/009,951, Dated Feb. 24, 2012.

Primary Examiner — Michael Kornakov

Assistant Examiner — Natasha Campbell

(74) *Attorney, Agent, or Firm* — Mintz Levin Cohn Ferris Glovsky and Popeo, P.C.

(57) **ABSTRACT**

A cleaning device for a medical implement is disclosed. The cleaning device includes a cap having an opening to an inner cavity, the opening being adapted to receive a site of the medical implement. The cleaning device further includes a compressible cleaning material that contains a cleaning agent prior to receipt of the site of the medical implement, i.e. the cleaning material is pre-loaded with the cleaning agent. The compressible cleaning material is at least partially secured in the inner cavity and adapted to swab and clean the site with the cleaning agent.

37 Claims, 7 Drawing Sheets

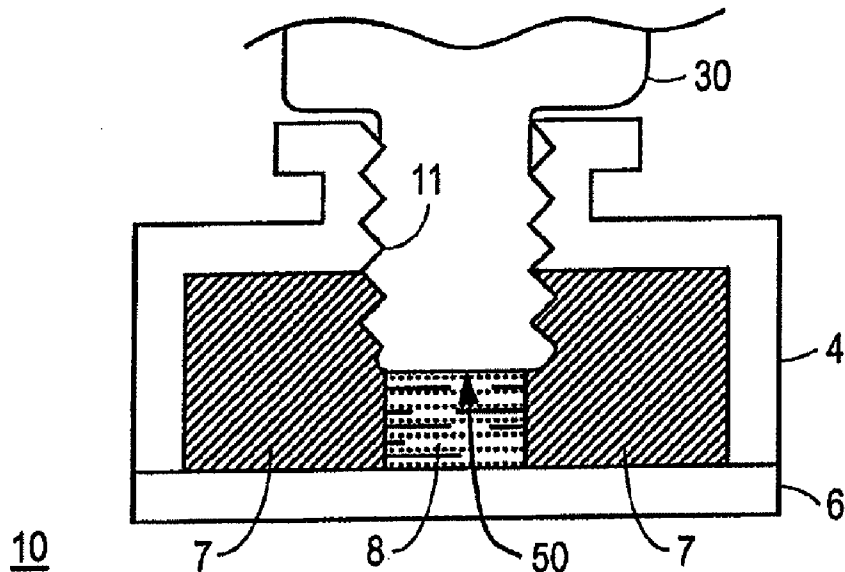

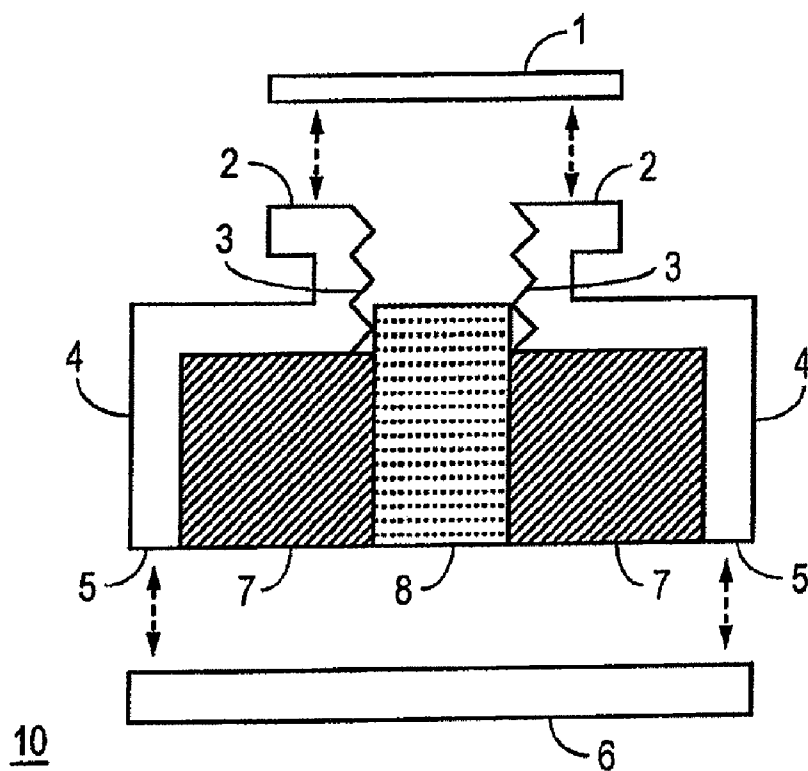

FIG. 1

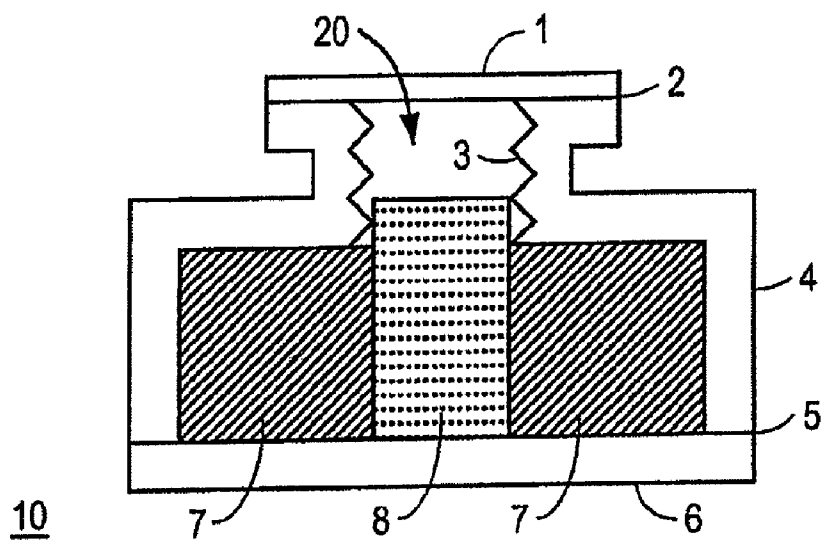
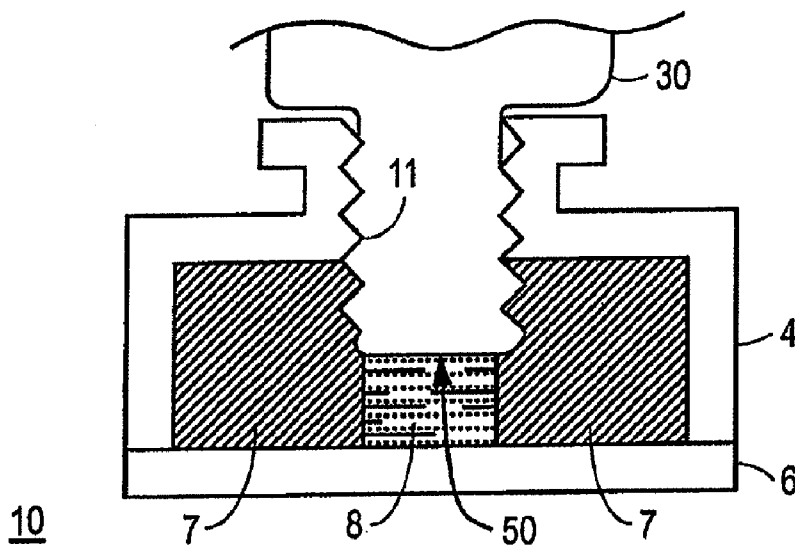
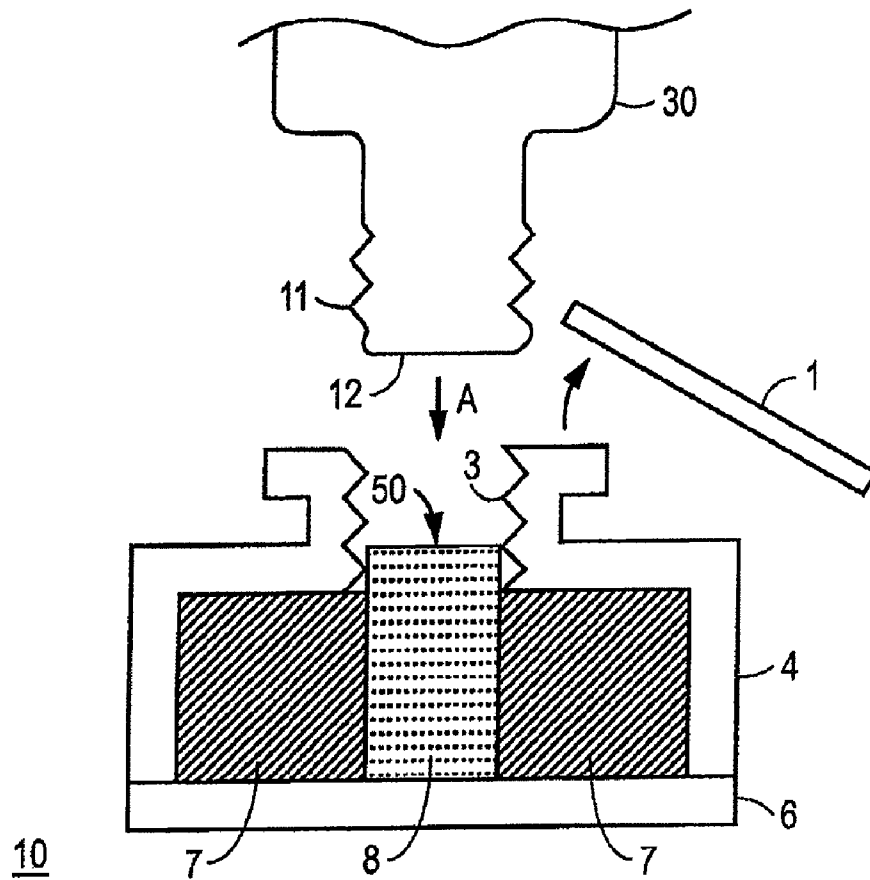

FIG. 2



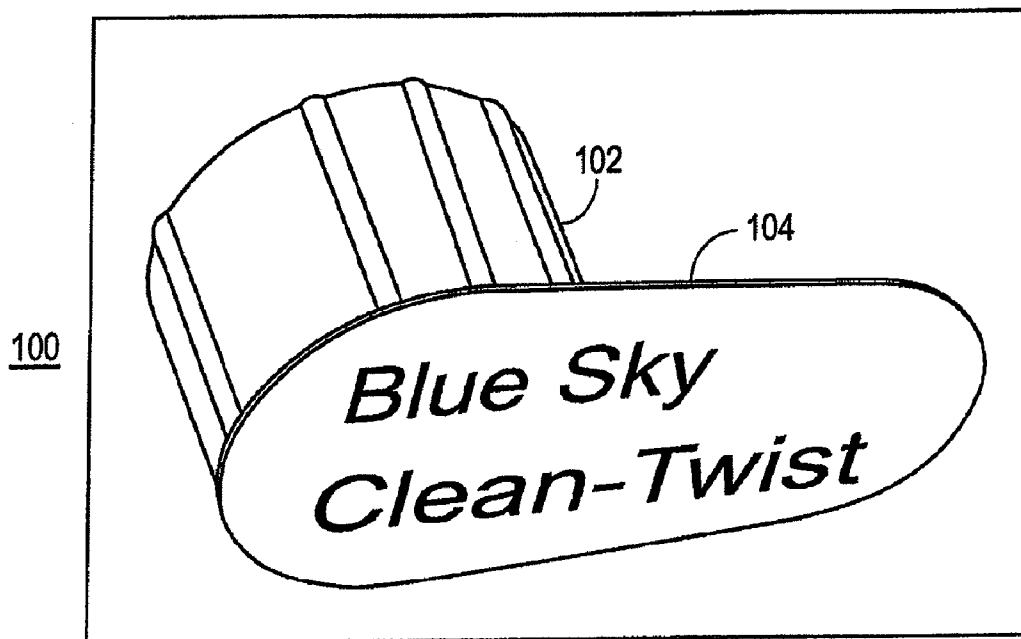

FIG. 5

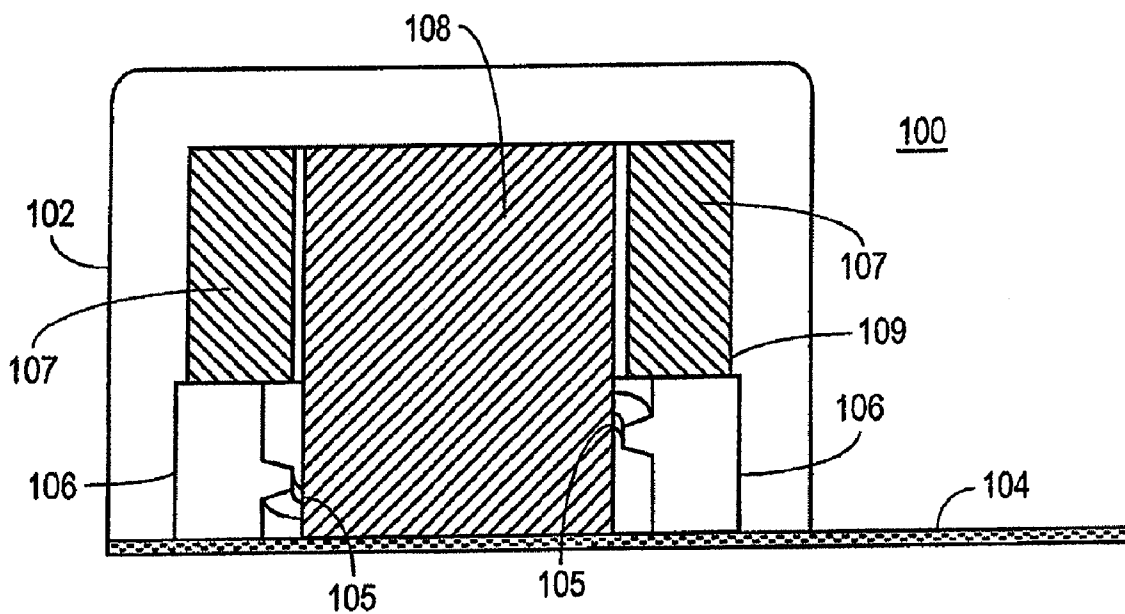

FIG. 6

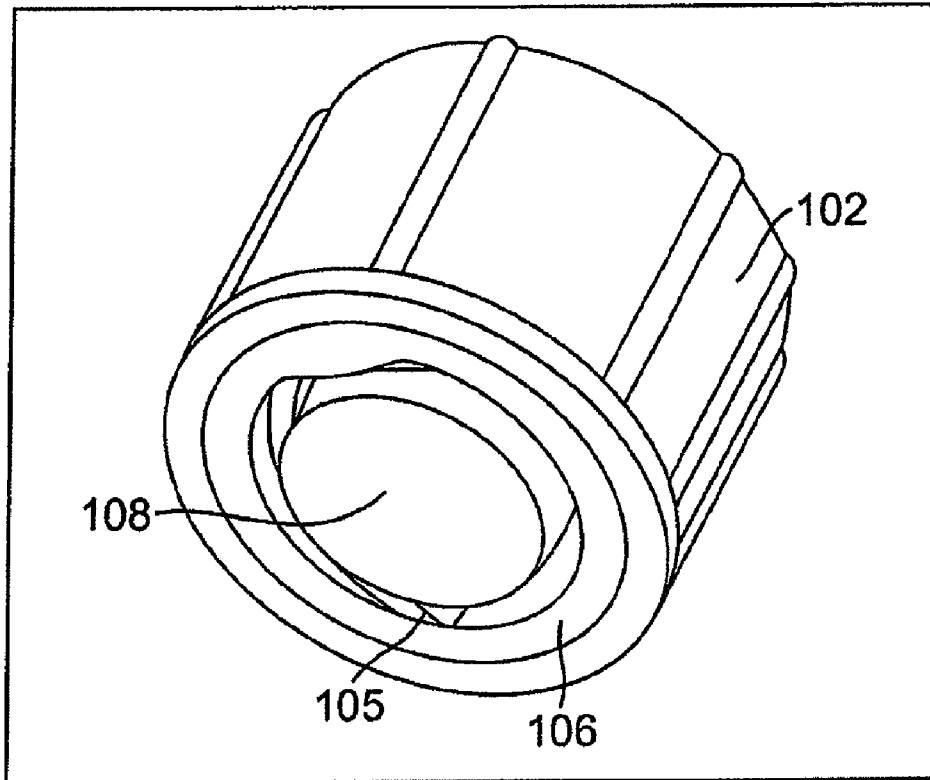

FIG. 7

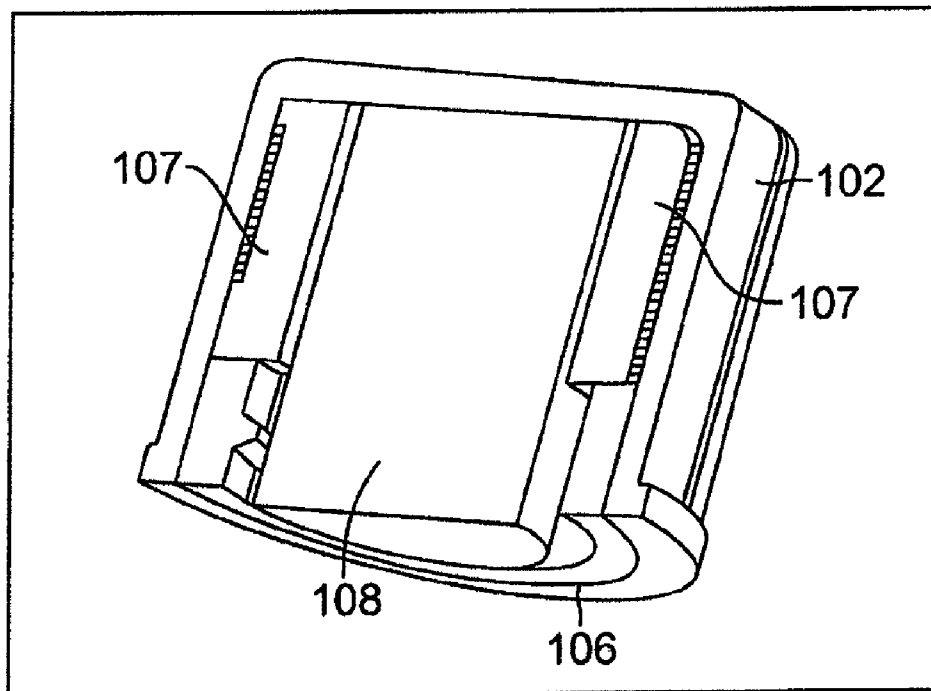

FIG. 8

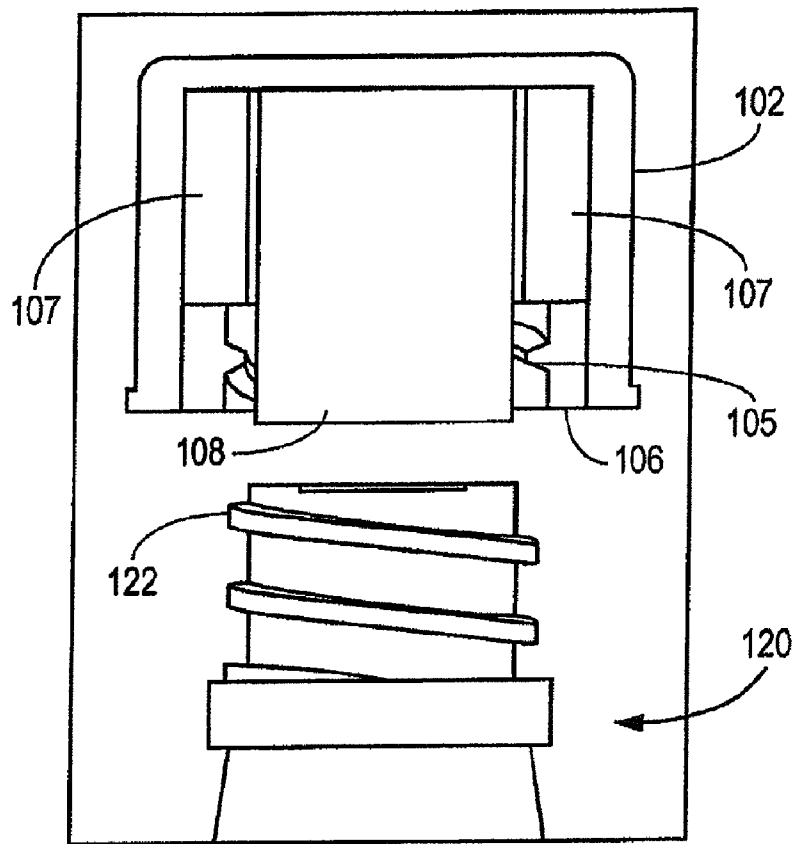

FIG. 9

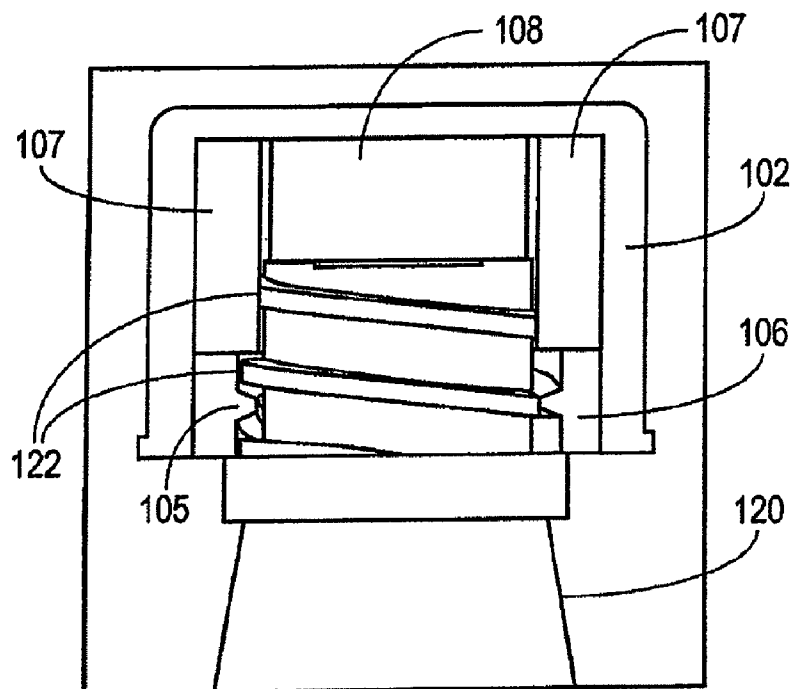

FIG. 10

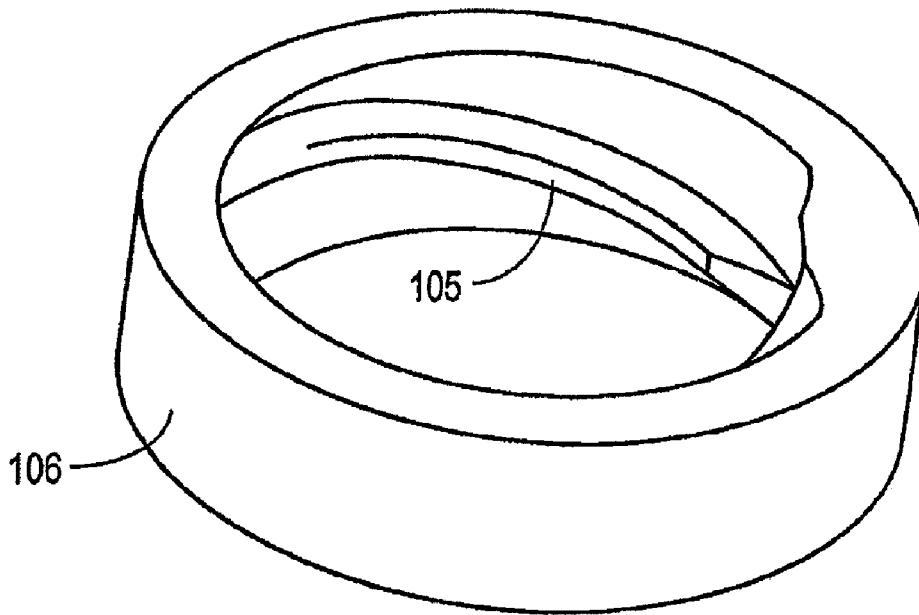

FIG. 11

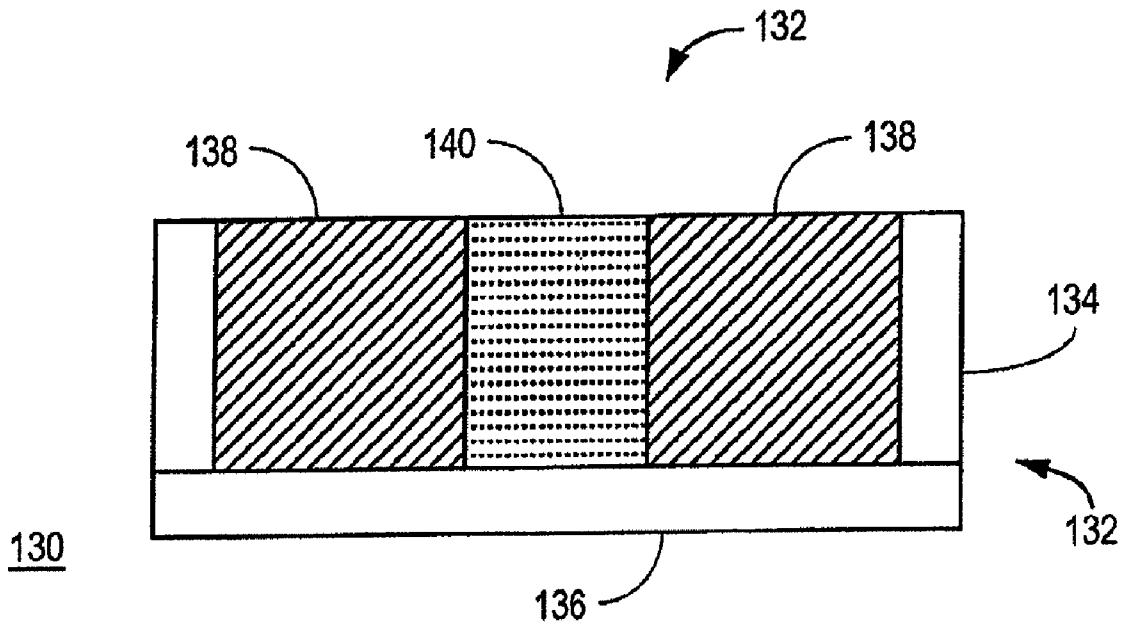

FIG. 12

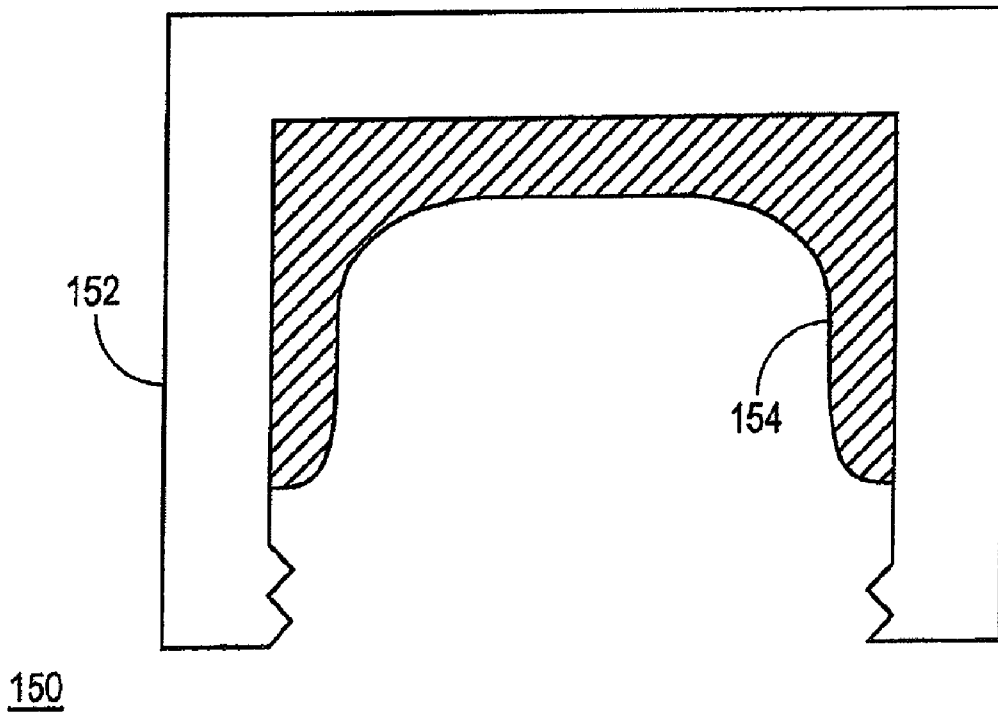

FIG. 13

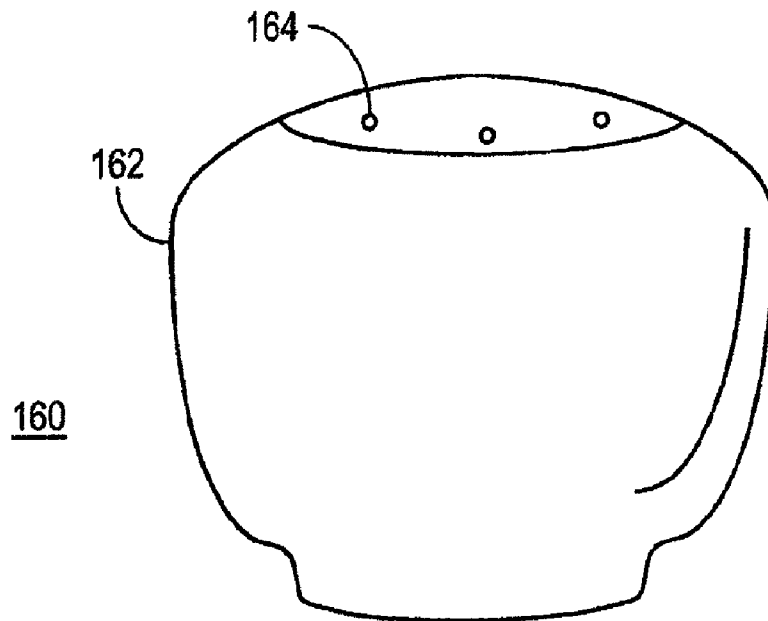

FIG. 14

US 8,206,514 B2

1

MEDICAL IMPLEMENT CLEANING DEVICE

PRIORITY

This application is a continuation of U.S. patent application Ser. No. 12/860,825 filed on Aug. 20, 2010, now U.S. Pat. No. 7,985,302, entitled "Medical Implement Cleaning Device," which is a continuation of U.S. patent application Ser. No. 11/705,805 filed on Feb. 12, 2007, issued on Aug. 24, 2010 as U.S. Pat. No. 7,780,794, and entitled "Medical Implement Cleaning Device," which claims the benefit under 35 U.S.C. §119(e) of U.S. provisional patent application Ser. No. 60/832,437 filed on Jul. 21, 2006 and entitled "Disinfecting Cap" and also claims the benefit under 35 U.S.C. §119(e) of U.S. Provisional patent application Ser. No. 60/850,438 filed on Oct. 10, 2006 and entitled "Disinfecting Cap." The disclosures of all applications to which the current application claims priority are incorporated by reference herein in their entireties.

BACKGROUND

Within the medical field, and in particular the area of infusion of fluids or aspiration of fluids to or from a patient, there is a need to prevent the transmission of pathogens into or onto a patient from a potentially contaminated surface of a medical implement, or "site". Such pathogens include microorganisms such as bacteria and viruses. The transmission of pathogens into a patient may result in an infection that could be life threatening. Specific to healthcare settings, the term "nosocomial infection" describes those infections that originate from or occur in a hospital or hospital-like setting. In the U.S., nosocomial infections are estimated to occur in at least 5% of all acute care hospitalizations. The estimated incidence is more than two million cases per year, resulting in an added expenditure in excess of \$4.5 billion. Nosocomial infections are estimated to more than double the mortality and morbidity risks of any admitted patient, and likely result in about 90,000 deaths a year in the United States. Common sites for such transmissions are found on such medical implements as a luer port, vial, needle free valve, or an injection port of a vessel, tubing, or catheter. Even non-intrusive medical implements such as stethoscopes can transmit pathogens to a patient. The incidence of infection in patients is presently numerous and increasing, and Infection Control Practitioners (ICP's) often cite improper cleaning of sites as a major source of these infections.

Traditionally, cleaning a potentially contaminated surface includes a protocol of alcohol swabbing prior to making the necessary connections to the site. Today alcohol swabs, a small pad of cotton gauze soaked in isopropyl alcohol, are packed individually in a foil package. The foil package is relatively inexpensive, and is used to retain the alcohol within the package and to prevent evaporation. Properly used, the package is opened at or near the site to be swabbed. With gloved hands, the pad is removed by a healthcare provider and wiped across the top and side surfaces of the site, and the pad and foil package are discarded. The site should be allowed to dry, usually twenty to thirty seconds, immediately prior to making any connection. This "drying" period is important: when alcohol dries, it breaks open the cellular walls of microorganisms, thereby killing them.

Unfortunately, because of increased duties and responsibilities, shrinking nursing staffs, and inadequate training, swabbing is often overlooked or is poorly executed. A poorly swabbed site can carry microorganisms that, if allowed to enter a patient's body, can cause serious infection. In addition,

2

supervisory oversight is nearly impossible, because unless a supervisor can actually observe the swabbing being performed, the supervisor cannot know whether or not it was done properly or performed at all. Further, without at least a sufficient microscopic examination for microbial residue, there may be no evidence of an alcohol swab being performed. Thus, a need exists for an apparatus and technique for cleaning a site on a medical implement prior to contact with a patient, and which will eliminate technique-related issues and training issues, and provide an unequivocal indicator that a site is clean prior to accessing a patient's vascular system.

SUMMARY

A cleaning device, system and method for a medical environment is disclosed. In one aspect, the cleaning device includes a cap having an opening to an inner cavity, the opening being adapted to receive a site of the medical implement. The cleaning device further includes a compressible cleaning material that contains a cleaning agent prior to receipt of the site of the medical implement, i.e. the cleaning material is pre-loaded with the cleaning agent. The compressible cleaning material is at least partially secured in the inner cavity and adapted to swab and clean the site with the cleaning agent.

In another aspect, a cleaning system for a threaded medical implement includes a cap having an inner cavity and an opening to receive a site of the medical implement into the inner cavity. The system further includes a threaded ring connected to the inner cavity at the opening to the cap, and having threads that correspond to threads on the threaded medical implement. The system further includes a cleaning material in the inner cavity adapted to provide radial compression against the threaded medical implement, the cleaning material containing a cleaning agent prior to receipt of the site of the medical implement. The opening is preferably covered by a removable vacuum seal.

In yet another aspect, a method of cleaning a site of a medical implement includes the steps of at least partially saturating a cleaning material with a cleaning agent in an inner cavity of a cap; and contacting a top of the site of the medical implement to a first portion of the cleaning material. The method further includes steps of compressing the first portion of cleaning material with the site of the medical implement to contact a side of the site with a second portion of the cleaning material provided around the first cleaning material, and attaching the cap over the site of the medical implement.

In yet another aspect, a cleaning device for a medical implement includes a cap having an opening to an inner cavity, an inner surface of the opening including one or more threads adapted to receive a site of the medical implement. The cleaning device further includes a cleaning material formed of a compressible material that is at least partially secured in the inner cavity, the cleaning material containing a cleaning agent.

In still yet another aspect, a cleaning system for a medical environment includes a plurality of caps. Each cap includes an inner cavity and an opening to receive a site of the medical implement into the inner cavity, and a cleaning material in the inner cavity adapted to provide radial compression against a site of a medical implement, the cleaning material containing a cleaning agent prior to receipt of the site of the medical implement. The system further includes a seal that covers the opening of each of the plurality of caps, and from which

US 8,206,514 B2

3

individual ones of the plurality of caps can be selectively removed to be used for cleaning the site of the medical implement.

The details of one or more embodiments are set forth in the accompanying drawings and the description below. Other features and advantages will be apparent from the description and drawings, and from the claims.

BRIEF DESCRIPTION OF THE DRAWINGS

These and other aspects will now be described in detail with reference to the following drawings.

FIG. 1 is a cross-sectional, exploded view of a cleaning device.

FIG. 2 is a cross-sectional view of an assembled cleaning device.

FIG. 3 illustrates operation of a cleaning device for connection to a site of a medical implement.

FIG. 4 illustrates a cleaning device connected to a medical implement and cleaning a site of the medical implement.

FIG. 5 shows another embodiment of an assembled cleaning device.

FIG. 6 is a cross-sectional view of an assembled cleaning device in accordance with an embodiment.

FIG. 7 is a perspective view of another cleaning device.

FIG. 8 is a cross section of a cleaning device.

FIGS. 9 and 10 show a cleaning device being used to clean a site of a medical implement.

FIG. 11 is a perspective view of a ring that attaches to a corresponding structure of a medical implement.

FIG. 12 is a cross sectional view of another alternative embodiment of a cleaning device.

FIG. 13 shows yet another alternative embodiment of a cleaning device.

FIG. 14 shows a cap of a cleaning device in accordance with some embodiments.

Like reference symbols in the various drawings indicate like elements.

DETAILED DESCRIPTION

In accordance with preferred embodiments, a cleaning device includes a cap having a shape and/or external features to promote easy gripping and a cleaning material in the cap that holds or is in contact with a cleaning agent, such as isopropyl alcohol, for application of the cleaning agent to a site of a medical implement.

The cleaning material can be any substance that can conform, mold or compress in a manner that enables the effective wiping of the site, including the top surface of the site, side surface, and any threads or grooves, if present, and provide the cleaning agent at least at a surface level. Examples of the cleaning material include cotton, open or closed cell foam such as polyethylene foam, or other substance that can hold or carry the cleaning agent. The cleaning agent can be any chemical, substance or material that cleans the site of bacterial or even viral microorganisms, or any carrier that contains such chemical, substance or material. Examples of a cleaning agent include isopropyl alcohol, chlorhexidine, povidone-iodine, hydrogen peroxide, soap, and hydrochloric acid.

The term "medical implement" is used to denote any tool or object that can be used in a medical setting and that can connect to a site cleaning device as described herein according to a number of embodiments. Examples of medical implements include, but are not limited to, access ports on tubing sets (extension sets, T-connectors and IV sets), access ports on catheters (both peripheral and central lines), needle free

4

valves, stopcocks, luer connectors, stethoscopes and other components or devices whereby regular cleaning is desired. Medical implements are commercially available in standard sizes. Thus, the end or opening of a site cleaning device can be provided with fittings to accommodate such standard size medical implements.

The cap of the cleaning device is made of a material that is compatible with the cleaning materials and agents to be used, examples of materials would include, sealed foam, plastic, glass, or metal. The cleaning device may need to undergo sterilization. For securing the cleaning device to another device, the cleaning device can include attachment mechanisms such as "snap-fit" mechanisms or clamps to hold it in place on the other device. Alternatively the cleaning material in the cap may conform to the sides of the medical implement to thereby "grip" and remain secured to the medical implement. The cap also may have threading to secure it in place on a medical implement. The cap may have some cutaway portions on its walls to enable the use of some undercuts during the molding process, and to allow the cleaning material to flex outward both during use. The cap can be made from polyethylene or another material that is stable when in the presence of alcohol or other cleaning agent.

In preferred exemplary embodiments, prior to being applied to a site, and after the cleaning material is provided with a cleaning agent, the opening of the cap is sealed with a foil-based seal or other material suitable for retaining a cleaning agent in the cleaning material and preventing evaporation of the cleaning agent. The cap seal may also be formed in a manner whereby several caps could be attached i.e. a strip, where individual caps can be peeled from the strip in order to be used. These strips of caps can be made conveniently accessible, i.e. hung from intravenous (IV) poles or IV sets, in patient rooms and medication carts, to name just a few. The strips provide the convenience of having several caps available in one location.

The cleaning material in the cap can be an alcohol-soaked piece of gauze, foam or similar cleaning material. The cleaning material can be formed into the general interior shape of the cap from one or more pieces. For instance, the cleaning material can include a ring for circumscriptive coverage and cleaning of the site, and further include a cylinder within the ring for coverage and cleaning on a distal end of the site. A single piece of cleaning material may also be cut or formed to perform the same coverage and cleaning functions as the two pieces described above. The cleaning material may also cover the threads and/or be formed as part of the threads.

In still further embodiments, the cleaning material may be made entirely or partially of the cleaning agent. For example, the cleaning material can be formed of an open cell foam or plastic that is chemically or physically impregnated with a cleaning agent such as povidone or iodine, or isopropyl alcohol.

To further illustrate and describe these concepts, reference is now made to FIG. 1, which shows a cross-sectional, exploded view of a cleaning device, embodied as a cap 10 with a housing 4 that defines an inner cavity 20 of the cap 10. A foil seal 1 is configured to attach to a sealing surface 2 of the housing 4. The housing 4 further includes internal threads 3. In a preferred exemplary embodiment, the internal threads 3 are sized and arranged to accommodate luer threads, i.e. standardized male threads designed to mate with the female threads on a medical implement to which the cap 10 attaches. The housing 4 also has a mating surface 5 for attachment of a bottom portion 6.

Within housing 4 is a first cleaning material 7. The first cleaning material 7 may be attached to the walls of housing 4

US 8,206,514 B2

5

by glue, solvent or some other attachment composition or mechanism, or may be held in the housing 4 by compression or trapped between the bottom portion 6 and housing 4. Ribs or protrusions on the inside of the housing 4 may also be used to prevent the cleaning material 7 from slipping or rotating. The first cleaning material 7 is compressible, and is preferably doughnut-shaped or ring-shaped. The first cleaning material 7 is positioned and configured to compress radially in an outwardly direction to scrub or wipe the circumscriptive surface of the site and the surface of the threads of an inserted medical implement.

A second cleaning material 8 is designed to compress in the axial direction upon insertion of the medical implement and is designed to wipe the distal end and distal surface of the inserted medical implement. The second cleaning material 8 may be attached to the walls of bottom portion 6 by glue, solvent or some other attachment composition or mechanism, or affixed to first material 7 by glue, solvent or some other attachment composition or mechanism. Protrusions on the inside of the bottom portion 6 may also be used to prevent the cleaning material 8 from rotating or removal. The first cleaning material 7 and second cleaning material 8 may be formed from a single piece of compressible cleaning material of cotton, foam or other suitable cleaning material adapted for scrubbing. This single piece may be cut completely or partially cut to achieve a similar effect as two separate pieces of cleaning material.

FIG. 2 illustrates an assembled cap 10. The first and second cleaning materials 7 and 8 in the inner cavity 20 are at least partially saturated with a cleaning agent, such as isopropyl alcohol, or a mix of cleaning agents. The foil seal 1 is then attached to housing 4 at sealing surface 2 by glue, solvent, thermal bonding, etc. A bottom portion 6 is attached to housing 4 at point 5 by glue, welding, solvent, threads or other attachment mechanism or process. With the foil seal 1 and the bottom portion 6 attached to housing 4, the inner cavity 20 is hermetically sealed. The housing 4, bottom portion 6, and first and second cleaning materials 7, 8 are respectively made of a material or cleaning materials that are compatible with the cleaning agent. For instance, if isopropyl alcohol is used for at least part of the cleaning agent, the housing 4 and bottom portion 6 can be constructed of a plastic such as polyethylene. The housing 4 and bottom portion 6 can be formed of a unitary piece of material, as explained further below.

FIG. 3 illustrates a medical implement 30 moving toward housing 4, in a direction A, which should be recognized as a reference only, and that the housing 4 can likewise be moved toward the medical implement 30. The foil seal 1 is removed from housing 4. In alternative embodiments, the foil seal 1 can be a foil pouch or other sterilized material that would inhibit evaporation of the cleaning agent. A distal end surface 12 of the medical implement 30 is eventually contacted with the upper surface 50 of the second cleaning material 8.

As the medical implement 30 continues in direction A, it axially compresses second cleaning material 8 continuing to clean surface 12 with surface 50. This movement also begins to radially compress the first cleaning material 7 and to conform the first cleaning material 7 with, and begin scrubbing, threads 11. The cleaning materials 7 and 8 contain the cleaning agent so as to perform a thorough cleaning of the area about the threads 11 and the surface 12. As threads 11 of the medical implement 30 continue to be rotationally inserted into the threads 3 of the housing, the distal end surface 12 is automatically scrubbed by surface 50 of the second cleaning material 8 and cleaned by cleaning agent held therein, and at least a portion of the side and threads 11 of the medical

6

implement 30 are automatically scrubbed by radial compression of the first cleaning material 7 and cleaned by a cleaning agent held therein. FIG. 4 illustrates the disinfecting cap 10 with a fully inserted medical implement 30.

The cap 10 can be removed immediately from the medical implement 30 after use, or be kept in place. If the cap 10 is removed the medical implement 30 surfaces 11 and 12 will be clean and ready for use upon the drying of the cleaning agent. If the cap 10 is kept secured to medical implement 30, the cleaning agent in cap 10 will evaporate over time thereby destroying any microorganisms on the surfaces 12 and 11 of medical implement 30. The cap 10 then maintains the surfaces 11 and 12 of medical implement 30 in a clean and ready-to-access state by eliminating any forms of touch contamination.

FIGS. 5-10 illustrate an alternate embodiment of a cleaning device 100. FIG. 5 is a perspective view of the cleaning device 100 formed of a cap 102 with a seal 104 that is connected to and covers the opening of the cap 102. The cap 102 can have a number of gripping ridges or projecting members for ease of use. FIG. 6 is a cross-sectional view of the cleaning device 100. The cap 102 forms an inner cavity with one opening that is large enough to receive a site of a medical implement. The seal 104 is affixed to the opening and is preferably entirely removable. In other embodiments, the seal 104 is permanently affixed, and is simply punctured by insertion of a site of a medical implement.

The cap 102 houses a threaded ring 106 proximate to the opening. The threaded ring 106 includes one or more threads 105 and is adapted to receive the site of the medical implement to be disinfected, and thus defines the size and shape of the opening. This embodiment is advantageous because it creates a single circumferential seal point, seal 104 to the opening of cap 102.

In some embodiments, the cap 102 and threaded ring 106 are formed of a unitary piece of material or cleaning material. In other embodiments, the threaded ring 106 fits into a groove 109 that is formed in the inside edge surface of the cap 102 near the opening. In this latter configuration, the groove 109 maintains the position of threaded ring 106 near the open end of the cap where the threaded ring top surface may be flush with or slightly recessed from the cap open end walls, and the threaded ring 106 may also include or create with the cap wall a small vent aperture or opening to allow evaporation of a cleaning agent in the cap 102. The threaded ring 106 can be mechanically kept from rotating with internal ribs or protrusions in cap 102 or groove 109. Threaded ring 106 may be held in place within groove 109 and cap 102 by glue, welding, snap-fit, solvent bonding or any other mechanism or composition known to those of requisite skill.

The cleaning device 100 further includes a first cleaning material 107 that holds the cleaning agent, such as isopropyl alcohol, and a second cleaning material 108 that also holds or is at least partially saturated by the cleaning agent. In preferred exemplary embodiments, the first cleaning material 107 is formed as a hollow cylinder or ring positioned between the threaded ring 106 and the top inside surface of the cap 102, and is adapted for radial compression against a site that is inserted into the cap 102 or over which the cap 102 is placed. In some embodiments, the second cleaning material 108 is formed as a solid cylinder and positioned within the hollow space of the first cleaning material 107, and is adapted for axial compression against a leading edge of the site that is inserted into the cap 102 or over which the cap 102 is placed. In other embodiments, cleaning materials 107 and 108 can be made of a single piece of material and cut or formed so as to achieve the same result as described above. The cleaning

US 8,206,514 B2

7

agent is provided to the cleaning materials **107**, **108** prior to the opening being covered with the seal **104**.

FIG. **7** is a bottom perspective view and FIG. **8** is a cross-sectional view of the cleaning device **100** with the seal **104** removed, showing the cap **102**, threaded ring **106** that sits within the cap **102**, and the second cleaning material **108** inside the cap **102**. The second cleaning material **108** can extend to and slightly beyond the opening of the cap **102**. FIG. **8** further shows the first cleaning material **107** that circumscribes the second cleaning material **108** and being positioned between the threaded ring **106** and the top inner surface of the cap **102**. FIG. **11** illustrates an example of the threaded ring **106** and its threads **105**. An attribute of this embodiment of the threaded ring **106** shown in FIG. **11** is that there are only two opposing threads that travel 180 degrees before terminating. This enables the molding of threaded ring **106** without the use of a screw to create the thread feature in an injection molding tool. The threaded ring **106** can also be produced with an injection molding tool utilizing a screw.

FIG. **9** illustrates the cleaning device **100** about to make contact with a site **120** of a medical implement. As discussed above, the site **120** can be a luer port, a, a needle free valve, an injection port of a vessel, or other medical implement that needs to be cleaned prior to use with a patient. In some embodiments, the site **120** can include a set of threads **122** that correspond to the threads **105** in the threaded ring **106** of the cleaning device **100**. The cleaning materials **107** and **108** are preloaded with a cleaning agent, before removal of the seal and contact by the site **120**. Accordingly, as shown in FIG. **10**, the site **120** makes contact with the cap **102** by a screwing motion relative to the cap **102**. The second cleaning material **108** is compressed axially and swabs against the leading edge of the site **120**, while the first cleaning material **107** is compressed radially and swabs against sides of the site **120**.

FIG. **11** illustrates the molded thread ring **106** with two opposing threads **105** that traverse opposing 180 degree portions of the ring. This design enables the thread ring **106** to be molded without the use of a screw that is typically used to create threaded parts in a molding process. Thus the threaded ring **106** can be manufacture very inexpensively. The threaded ring **106** can also clean some of the threads when the cap is placed into position, and may or may not cover all the threads. In some embodiments, the threaded ring **106** can be molded from the cleaning material, or the cleaning material is formed only of the threaded ring **106**. In such embodiments, the cleaning may only occur on threads of the site and in an axial direction.

FIG. **12** shows an alternative embodiment of a cleaning device **130** having a cap **132** that is filled with a cleaning material. The cap **132** has side walls **134** and a top **136** that define an inner cavity with an opening **132**. The cleaning material includes at least a first cleaning material **138**, such as cotton or foam, that delivers a cleaning agent. The cleaning material can include a second cleaning material **140** to hold more cleaning agent. In some embodiments, the second cleaning material **140** can be circumscribed by the first cleaning material **138**. Alternatively, the first cleaning material **138** can completely envelope the second cleaning material **140**, each providing their own compressibility and capacity to hold a cleaning agent. Still, in other embodiments, the first and second cleaning materials **138**, **140** can be formed of a single piece of material. The cleaning material(s) are filled at least partially with a cleaning agent, prior to sealing of the opening **132** with a seal and closure of the inner cavity.

FIG. **13** shows an alternate embodiment of a cleaning device **150**. In this embodiment, the cleaning device **150**

8

includes a housing **152** that is formed as a threaded cap. The inner surface of the housing **152** is covered, at least in part, by a cleaning layer **154** that is bonded to the inner surface of the housing **152**. The cleaning layer **154** can be a cleaning material such as cotton, foam, or other porous and pliable material that suitably holds and/or delivers a cleaning agent such as isopropyl alcohol. The cleaning layer **154** is sized and positioned inside the housing **152** so as to be able to swab the top and a portion of the sides of a part of a medical implement that is inserted therein, or over which the housing **152** is placed. Accordingly, the cleaning layer **154** can have any thickness or compressibility.

FIG. **14** shows yet another alternative embodiment of a cleaning device **160**, illustrating an outer view of a rounded housing **162** for an expanded inner chamber to hold more cleaning agents or cleaning materials that hold such agents. Holes **164** in the housing **162** can promote evaporation of the cleaning agent, particularly when the housing covers a site of a medical implement to be disinfected. The location of the vent holes is variable and the vent holes can also be sealed with a filter type membrane that permits the drying of the cleaning agents but does not allow entry of microorganisms or fluid.

The use of the various implementations and embodiments above entails the following: the healthcare worker would, with gloved hands, open the foil package and place this cap over the site of a medical implement to be cleaned. Upon placement the alcohol soaked cleaning material wipes all of the port's surfaces. This wipe could be accomplished by either a turning motion (if threads are used) or by simply pushing the cap onto the port. In this way the cap eliminates errors in the practice of swabbing due to poor training or excessive workloads. The cap would then remain secured in place by threads, mechanical tension provided by the foam, cotton, etc., snaps or some other mechanism. A cap in place on a medical implement is a positive indication that a desired site of the medical implement is clean. A vibrant color may be used to allow instant visualization of a cap's presence from a door or hallway. ICP's can review compliance by merely observing sites to see whether or not a cap is in place. The cap could remain in place for periods of up to three days or more. For extended periods the alcohol will likely evaporate, which assures that the site is clean. With the cap in place, it continues to keep the site clean even after the alcohol has evaporated.

Although a few embodiments have been described in detail above, other modifications are possible. For instance, any of the embodiments described above may be sized and scaled for a particular medical implement, such as a stethoscope. Other embodiments may be within the scope of the following claims.

The invention claimed is:

1. A cleaning device for a medical implement, the cleaning device comprising:

a cap having an opening to an inner cavity, the opening for receiving a site of the medical implement;

one or more protrusions extending inwardly at least partially around an inside surface of the cap near a periphery of the opening to the inner cavity, the one or more protrusions to engage an outer surface of the site of the medical implement to maintain the cap on the site of the medical implement;

a cleaning agent that occupies at least some of the inner cavity, the cleaning agent being formulated to clean the site when the opening of the cap receives the site of the medical implement;

US 8,206,514 B2

9

at least one aperture to the inner cavity to allow venting from the inner cavity when the opening of the cap receives the site of the medical implement; and a removable seal that covers the opening to maintain the cleaning agent within the inner cavity prior to receipt of the site of the medical implement.

2. The cleaning device in accordance with claim 1, wherein the at least one aperture is transiently formed during receiving the site of the medical implement.

3. The cleaning device in accordance with claim 1, wherein the at least one aperture is transiently formed as a gap between at least one of the one or more protrusions and an outer surface of the site of the medical implement.

4. The cleaning device in accordance with claim 1, wherein the at least one aperture is a gap between at least one of the one or more protrusions and an outer surface of the site of the medical implement.

5. The cleaning device in accordance with claim 1, wherein the venting from the inner cavity includes venting of at least a portion of the cleaning agent.

6. The cleaning device in accordance with claim 1, wherein the venting from the inner cavity includes releasing pressure from the inner cavity.

7. The cleaning device in accordance with claim 1, wherein the at least one aperture is proximate the one or more protrusions.

8. The cleaning device in accordance with claim 1, wherein the removable seal is connected to the opening prior to being removed.

9. The cleaning device in accordance with claim 1, wherein the at least one aperture is a gap in the one or more protrusions.

10. The cleaning device in accordance with claim 9, wherein the gap in the one or more protrusions is formed between an inner surface of the one or more protrusions and an outer surface of the site of the medical implement.

11. A cleaning device for a medical implement having a threaded access port, the cleaning device comprising:

a cap having an inner cavity for receiving the threaded access port of the medical implement;

a protrusion extending inwardly at least partially around an inside surface of the cap near a periphery of the opening to the inner cavity, the protrusion to engage at least a portion of the threaded access port of the medical implement to maintain the cap on the medical implement;

a cleaning agent that occupies at least some of the inner cavity, the cleaning agent being formulated to clean the threaded access port when the opening of the cap receives the threaded access port of the medical implement;

at least one aperture to the inner cavity to allow venting from the inner cavity when the inner cavity receives the threaded access port of the medical implement; and a removable seal that covers the opening to maintain the cleaning agent within the inner cavity prior to receipt of the site of the medical implement.

12. The cleaning device in accordance with claim 11, wherein the at least one aperture is transiently formed when the inner cavity receives the threaded access port of the medical implement.

13. The cleaning device in accordance with claim 11, wherein the venting from the inner cavity includes venting of at least a portion of the cleaning agent.

14. The cleaning device in accordance with claim 11, wherein the venting from the inner cavity includes releasing pressure from the inner cavity.

10

15. The cleaning device in accordance with claim 11, wherein when the inner cavity receives the threaded access port of the medical implement, at least a portion of threads of the threaded access port are exposed to the cleaning agent.

16. The cleaning device in accordance with claim 11, wherein when the inner cavity receives the threaded access port of the medical implement, at least a portion of threads of the threaded access port extend beyond the protrusion and into the inner cavity.

17. The cleaning device in accordance with claim 11, further comprising a compressible cleaning material in the inner cavity and containing the cleaning agent, the compressible cleaning material adapted to swab and clean the threaded access port with the cleaning agent.

18. The cleaning device in accordance with claim 11, wherein the at least one aperture is transiently formed by a gap between the protrusion and the threaded access port of the medical implement.

19. The cleaning device in accordance with claim 11, wherein the at least one aperture is a gap in the protrusion.

20. The cleaning device in accordance with claim 19, wherein the gap in the protrusion is formed between an inner surface of the protrusion and an outer surface of the threaded access port of the medical implement.

21. A method for cleaning a threaded access port of a medical implement, the method comprising:

providing a cleaning device comprising a cap having an inner cavity for receiving the threaded access port, a protrusion extending inwardly at least partially around an inside surface of the cap near a periphery of the opening to the inner cavity to engage at least a portion of the threaded access port, a cleaning agent that occupies at least some of the inner cavity and being formulated to clean the threaded access port when the opening of the cap receives the threaded access port, at least one aperture to the inner cavity to allow venting from the inner cavity when the inner cavity receives the threaded access port, and a seal that covers the opening to maintain the cleaning agent within the inner cavity prior to receipt of the site of the medical implement;

removing the seal to expose the opening to the threaded access port; and

placing the cap on the threaded access port to contact the threaded access port with the cleaning agent.

22. The method in accordance with claim 21, further comprising venting the inner cavity via the at least one aperture after the cap is placed on the threaded access port.

23. The method in accordance with claim 21, wherein the at least one aperture is transiently formed when the cap covers the threaded access port of the medical implement.

24. The method in accordance with claim 21, wherein the venting includes venting the cleaning agent from the inner cavity.

25. The method in accordance with claim 21, wherein the protrusion includes a thread at the opening to the inner cavity of the cap.

26. The method in accordance with claim 21, wherein the at least one aperture is a gap in the protrusion.

27. The method in accordance with claim 21, further comprising engaging the threaded access port with the protrusion.

28. The method in accordance with claim 26, wherein the gap in the protrusion is formed between an inner surface of the protrusion and an outer surface of the threaded access port of the medical implement.

29. A cleaning system for a plurality of medical implements, the cleaning system comprising:

a strip of sealing material; and

US 8,206,514 B2

11

a plurality of cleaning devices removably attached to the strip of sealing material, each cleaning device being attached such that the sealing material encloses an inner cavity to each cleaning device, each inner cavity having an opening for receiving a site of one of the plurality of medical implements upon removal from the strip of sealing material, each cleaning device further comprising: one or more protrusions extending inwardly at least partially around an inside surface of the cap near a periphery of the opening to the inner cavity, the one or more protrusions to engage an outer surface of the site of one of the plurality of medical implements to maintain the cap on the site of one of the plurality of medical implements;

a cleaning agent that occupies at least some of the inner cavity, the cleaning agent being formulated to clean the site when the opening of the cap receives the site of one of the plurality of medical implements; and

at least one aperture to the inner cavity to allow venting from the inner cavity when the opening of the cap receives the site of one of the plurality of medical implements.

30. The cleaning system in accordance with claim 29, wherein each cleaning device further comprises a cap having ridges for being gripped by a user to position the cleaning device on the site of one of the plurality of medical implements.

31. The cleaning system in accordance with claim 29, wherein the at least one aperture of each cleaning device is

12

transiently formed during receiving the site of one of the plurality of medical implements.

32. The cleaning system in accordance with claim 29, wherein the at least one aperture of each cleaning device is transiently formed as a gap between at least one of the one or more protrusions and an outer surface of the site of one of the plurality of medical implements.

33. The cleaning system in accordance with claim 29, wherein the at least one aperture of each cleaning device is a gap in the one or more protrusions.

34. The cleaning system in accordance with claim 29, wherein the venting from the inner cavity of each cleaning device includes venting of at least a portion of the cleaning agent.

35. The cleaning system in accordance with claim 29, wherein the venting from the inner cavity of each cleaning device includes releasing pressure from the inner cavity.

36. The cleaning system in accordance with claim 29, wherein the at least one aperture of each cleaning device is proximate the one or more protrusions of each cleaning device.

37. The cleaning system in accordance with claim 33, wherein the gap in the one or more protrusions is formed between at least one of the one or more protrusions and an outer surface of the site of one of the plurality of medical implements.

* * * * *