

# EXHIBIT “B”

(12) **United States Patent**  
**Thistle et al.**

(10) **Patent No.:** **US 6,214,025 B1**  
 (45) **Date of Patent:** **Apr. 10, 2001**

(54) **SELF-CENTERING, SELF-EXPANDING AND RETRIEVABLE VENA CAVA FILTER**

FOREIGN PATENT DOCUMENTS

(75) Inventors: **Robert Thistle**, Brockton; **Iiya Yampolsky**, West Roxbury; **Sepideh H. Nott**, Melrose; **Hannah S. Kim**, Stow; **Naroun Suon**, Lawrence; **David Lee Sandock**, deceased, late of Littleton, all of MA (US), by Edna Ruth Sandock, executrix

3417738	11/1985	(DE)	.
0 348 295 A1	12/1989	(EP)	.
0 430 848 A1	5/1991	(EP)	.
0 437 121 A2	7/1991	(EP)	.
0 462 008 A1	12/1991	(EP)	.
0 472 334 A1	2/1992	(EP)	.
8 909 642	7/1989	(FR)	.
2 649 884	1/1991	(FR)	.
2 200 848	8/1988	(GB)	.
2 200 848	2/1991	(GB)	.
835447	5/1979	(SU)	.
1103868	7/1983	(SU)	.
955912	2/1988	(SU)	.
WO 91/04716	4/1991	(WO)	.
WO 91/11972	8/1991	(WO)	.
WO 95/09567	4/1995	(WO)	.

(73) Assignee: **Boston Scientific Corporation**, Natick, MA (US)

(\*) Notice: Subject to any disclaimer, the term of this patent is extended or adjusted under 35 U.S.C. 154(b) by 0 days.

(21) Appl. No.: **09/427,917**  
 (22) Filed: **Oct. 27, 1999**

OTHER PUBLICATIONS

**Related U.S. Application Data**

Kraimps, et al., "Conical Endocaval Filters With Metallic Struts: Search for a New Model", Mar. 1992, Ann. Vasc. Surg., 6:99-110.

(63) Continuation-in-part of application No. 08/849,392, filed on Nov. 10, 1997, now Pat. No. 6,013,093, which is a continuation-in-part of application No. 08/346,733, filed on Nov. 30, 1994, now Pat. No. 5,709,704.

Kraimps, et al., "Optimal Central Trapping (OPCETRA) Vena Cava Filter: Results of Experimental Studies", Nov. 1992, J. of Vasc. and Inter. Rad., 3:697-701.

(51) **Int. Cl.<sup>7</sup>** ..... **A61M 29/00**  
 (52) **U.S. Cl.** ..... **606/200**  
 (58) **Field of Search** ..... 606/200, 108, 606/194, 198; 604/104-108

*Primary Examiner*—Michael Buiz  
*Assistant Examiner*—Hoa B. Trinh  
 (74) *Attorney, Agent, or Firm*—Hoffman & Baron, LLP

(56) **References Cited**

(57) **ABSTRACT**

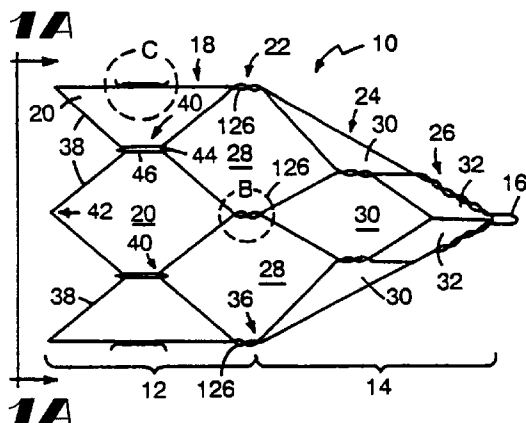
U.S. PATENT DOCUMENTS

3,540,431	11/1970	Mobin-Uddin et al. .
3,952,747	4/1976	Kimmell, Jr. .
4,425,908	1/1984	Simon .
4,494,531	1/1985	Gianturco .
4,619,246	10/1986	Molgaard-Nielsen et al. .
4,643,184	2/1987	Mobin-Uddin .
4,655,771	4/1987	Wallsten .
4,688,553	8/1987	Metals .
4,727,873	3/1988	Mobin-Uddin .
4,781,177	11/1988	Lebigot .

A self-centering blood clot filter is provided. The filter includes an anchoring portion including a generally cylindrical radially expandable body including an axial lumen extending therethrough. The filter further includes a filtering portion including a conical body concentrically aligned within the axial lumen of the anchoring portion. The conical body of the filtering portion is tapered to form a distal tip. As such, the blood clot filter can be properly centered within the lumen of a vessel for effective lysing of blood clots.

(List continued on next page.)

**43 Claims, 10 Drawing Sheets**



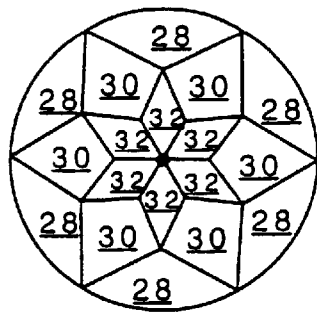
**US 6,214,025 B1**

Page 2

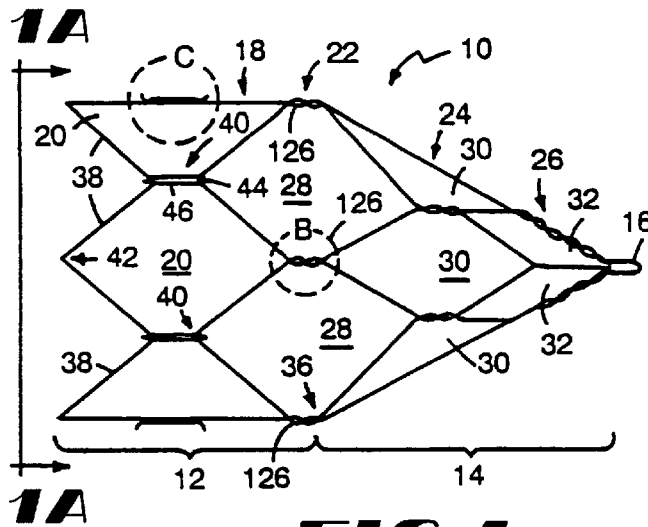
U.S. PATENT DOCUMENTS

			5,135,516	8/1992	Sahatjian et al. .
			5,152,777	10/1992	Goldberg et al. .
4,793,348	12/1988	Palmaz .	5,160,342	11/1992	Reger et al. .
4,817,600	4/1989	Herms et al. .	5,190,546	3/1993	Jervis .
4,830,003	5/1989	Wolff et al. .	5,221,261	6/1993	Termin et al. .
4,832,055	5/1989	Palestrant .	5,224,953	7/1993	Morgentaler .
4,856,516	8/1989	Hillstead .	5,300,086	4/1994	Gory et al. .
4,873,978	* 10/1989	Ginsburg ..... 606/200	5,304,121	4/1994	Sahatjian .
4,943,297	7/1990	Saveliev et al. .	5,304,200	4/1994	Spaulding .
4,954,126	9/1990	Wallsten .	5,324,304	* 6/1994	Rasmussen ..... 606/200
4,957,501	9/1990	Lahille et al. .	5,329,942	7/1994	Gunther et al. .
4,969,891	11/1990	Gewertz .	5,344,427	9/1994	Cottenceau et al. .
4,990,156	2/1991	Lefebvre .	5,370,657	12/1994	Irie .
5,059,205	10/1991	El-Nounou et al. .	5,375,612	12/1994	Cottenceau et al. .
5,061,275	10/1991	Wallsten et al. .	5,382,261	1/1995	Palmaz .
5,071,407	12/1991	Termin et al. .	5,405,377	4/1995	Cragg .
5,108,418	4/1992	Lefebvre .	5,476,508	12/1995	Amstrup .
5,108,419	4/1992	Reger et al. .			
5,133,733	7/1992	Rasmussen et al. .			

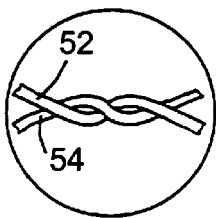
\* cited by examiner



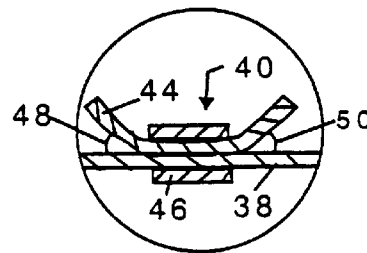
**FIG 1A**



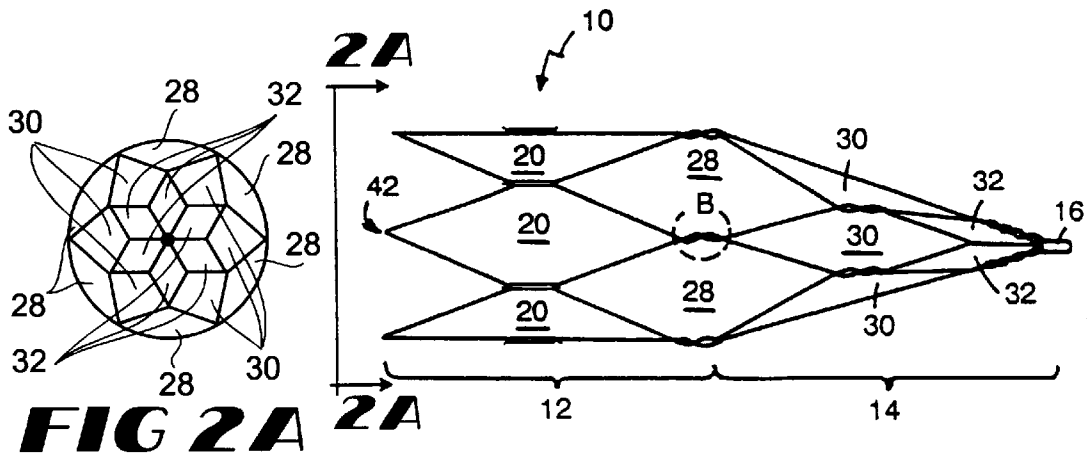
**FIG 1**



**FIG 1B**

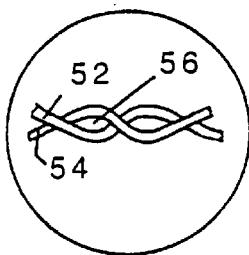


**FIG 1C**

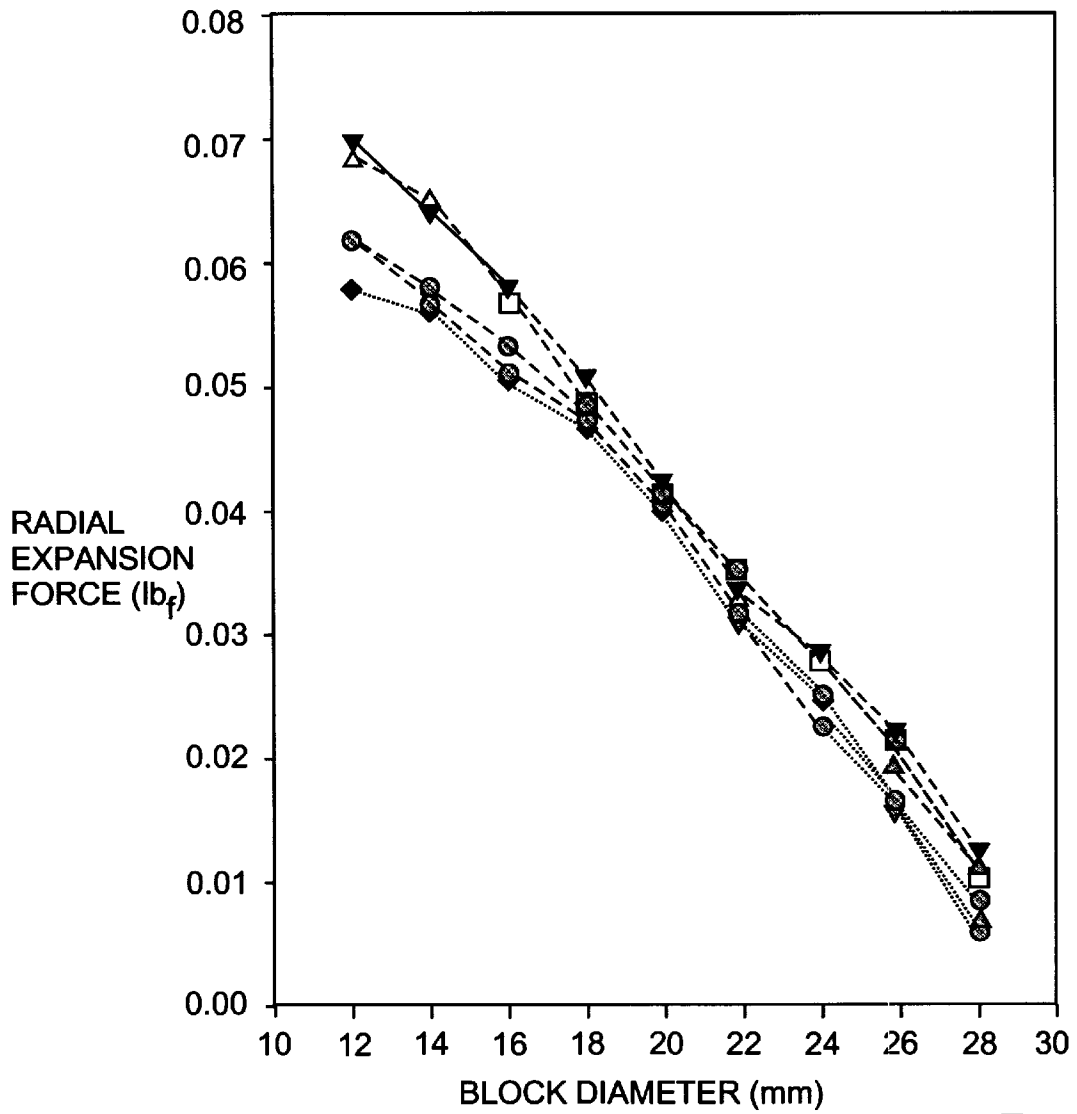


**FIG 2A**

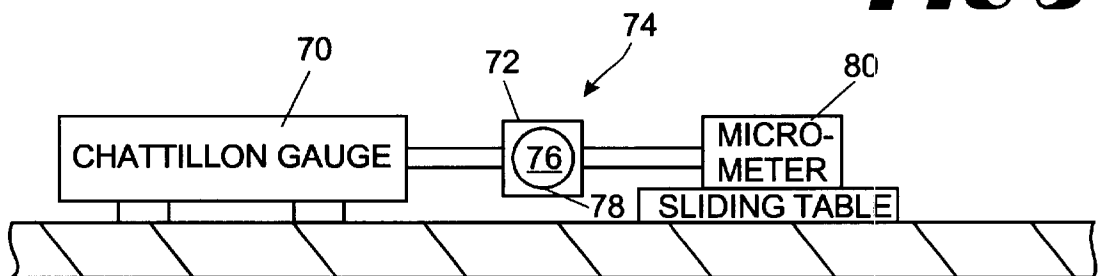
**FIG 2**



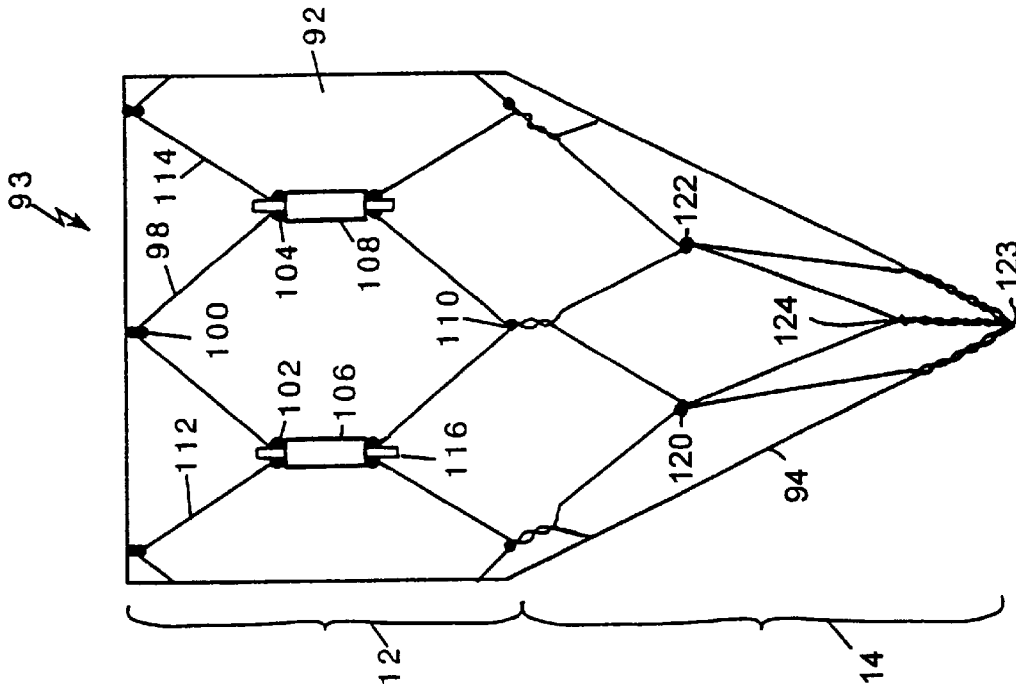
**FIG 2B**



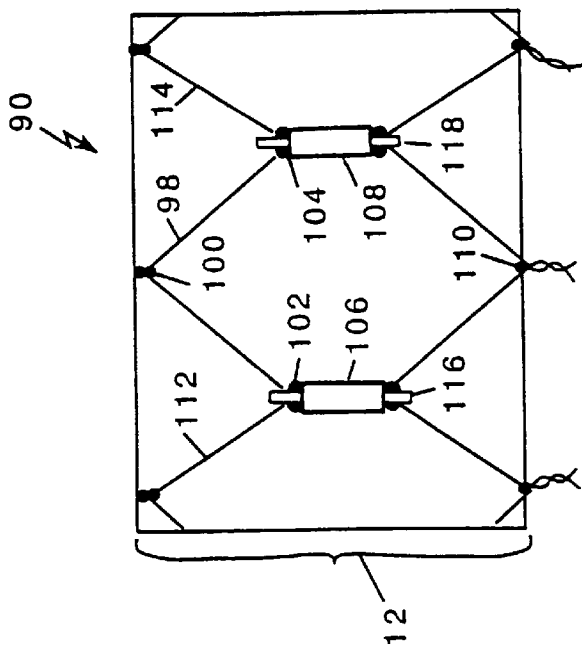
**FIG 3**



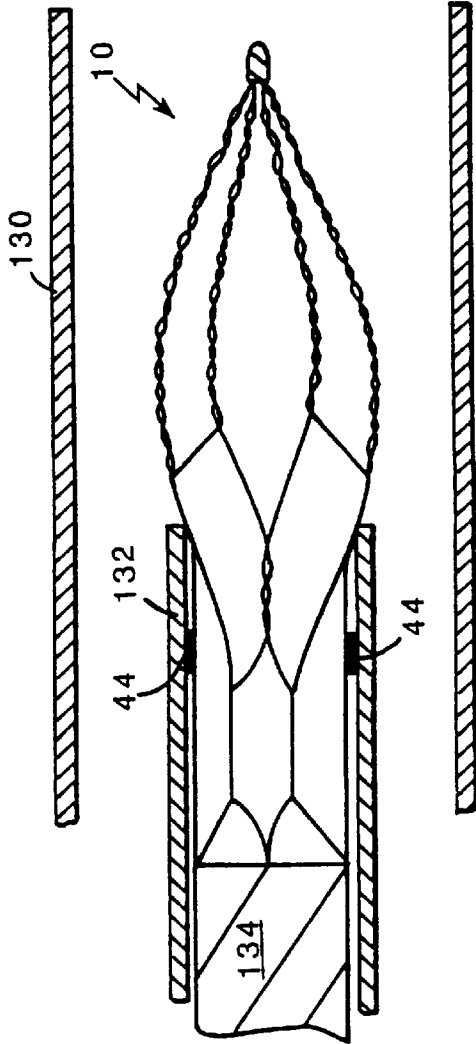
**FIG 3A**



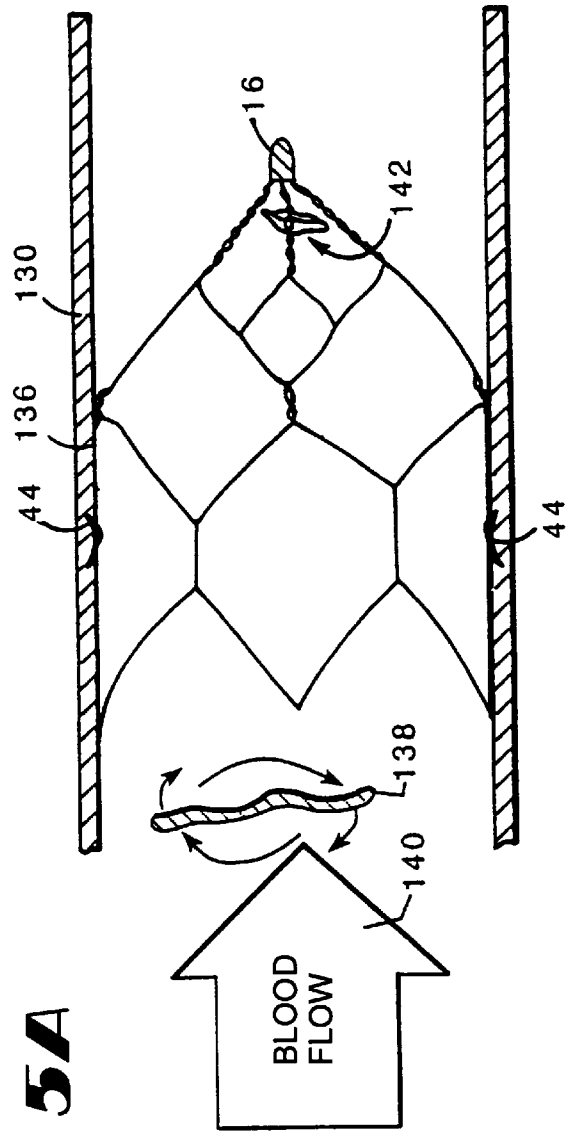
**FIG 4A**



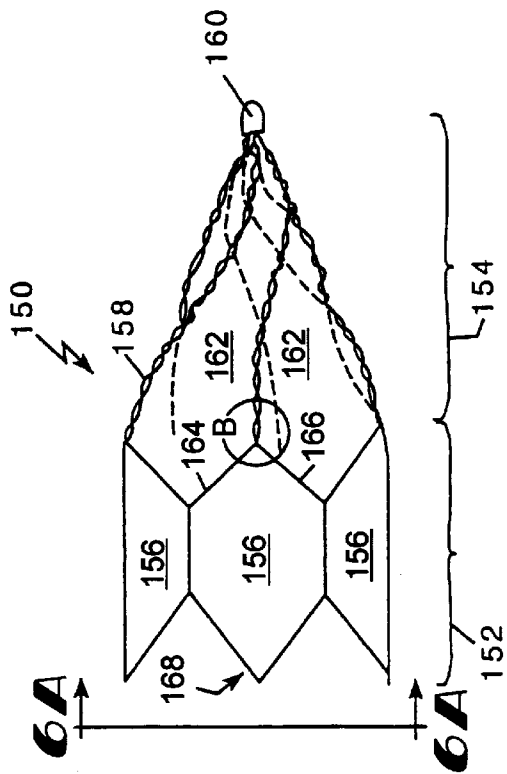
**FIG 4**



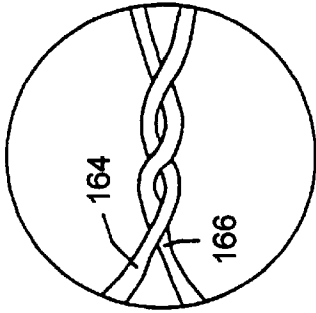
**FIG 5**



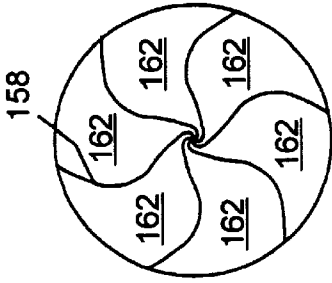
**FIG 5A**



**FIG 6A**



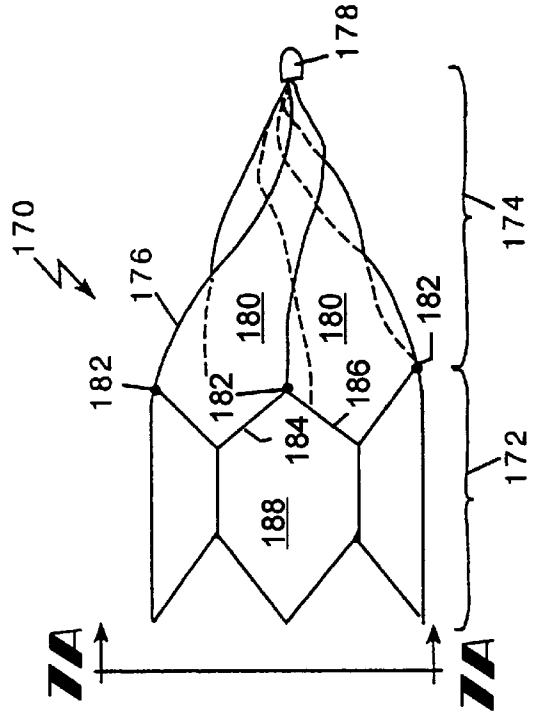
**FIG 6B**



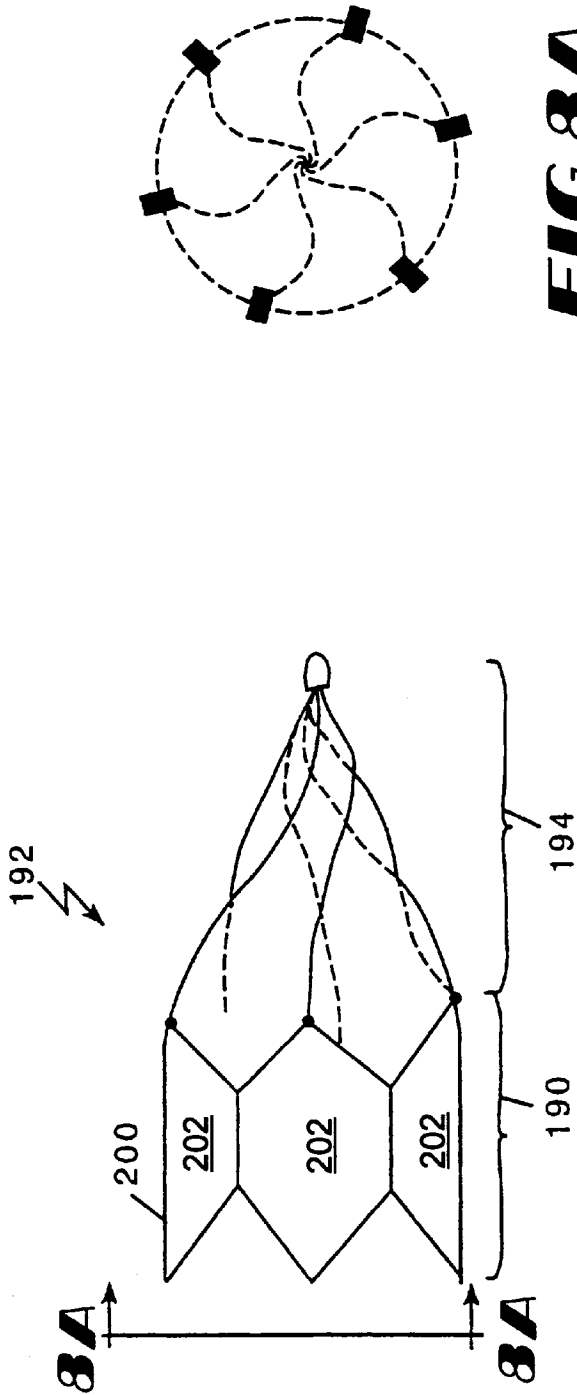
**FIG 7A**

**FIG 6**

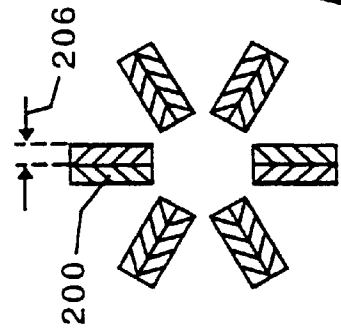
**FIG 7**





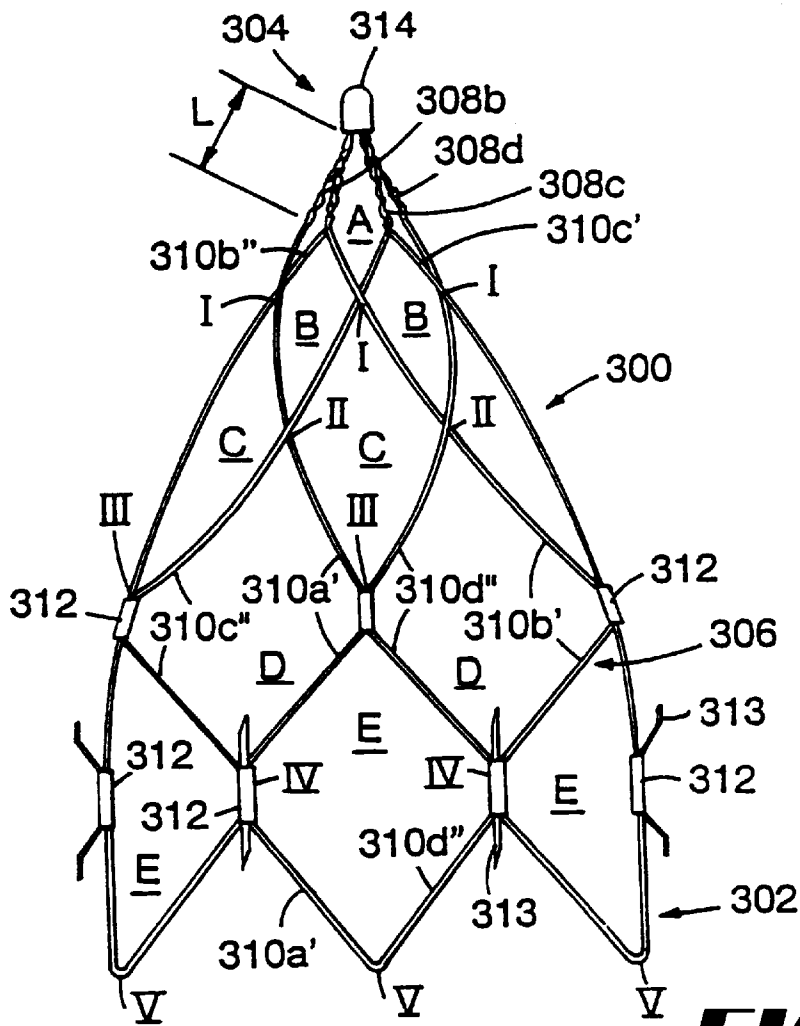


**FIG 8A**

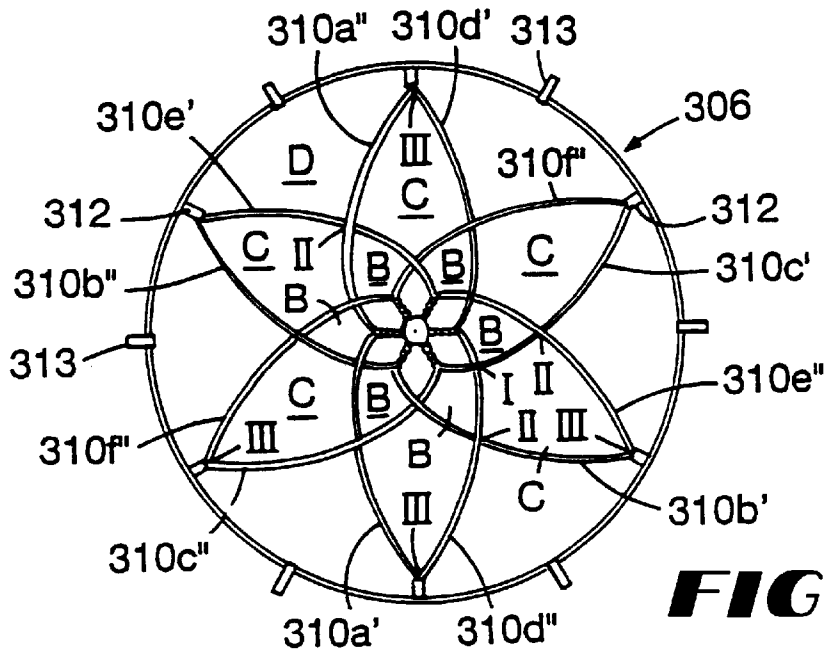


**FIG 8B**

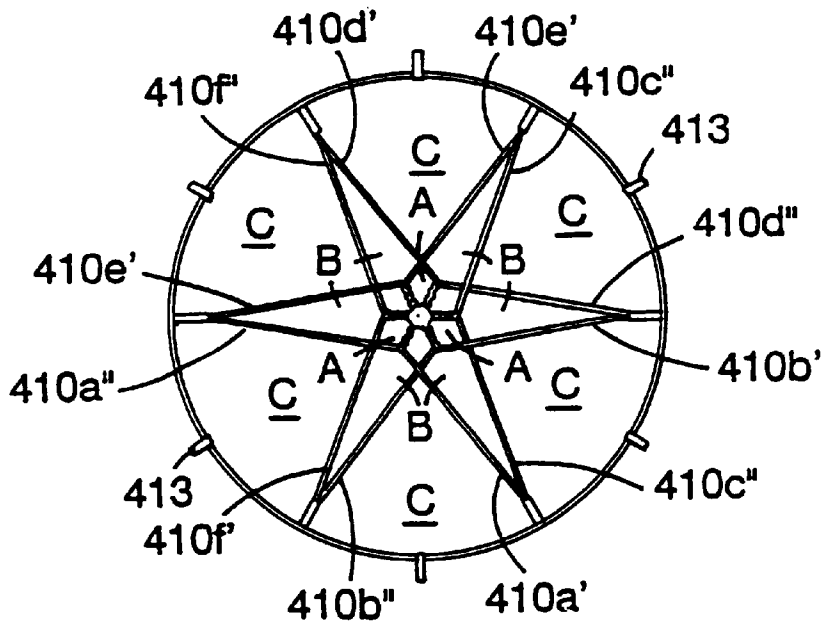
**FIG 8**



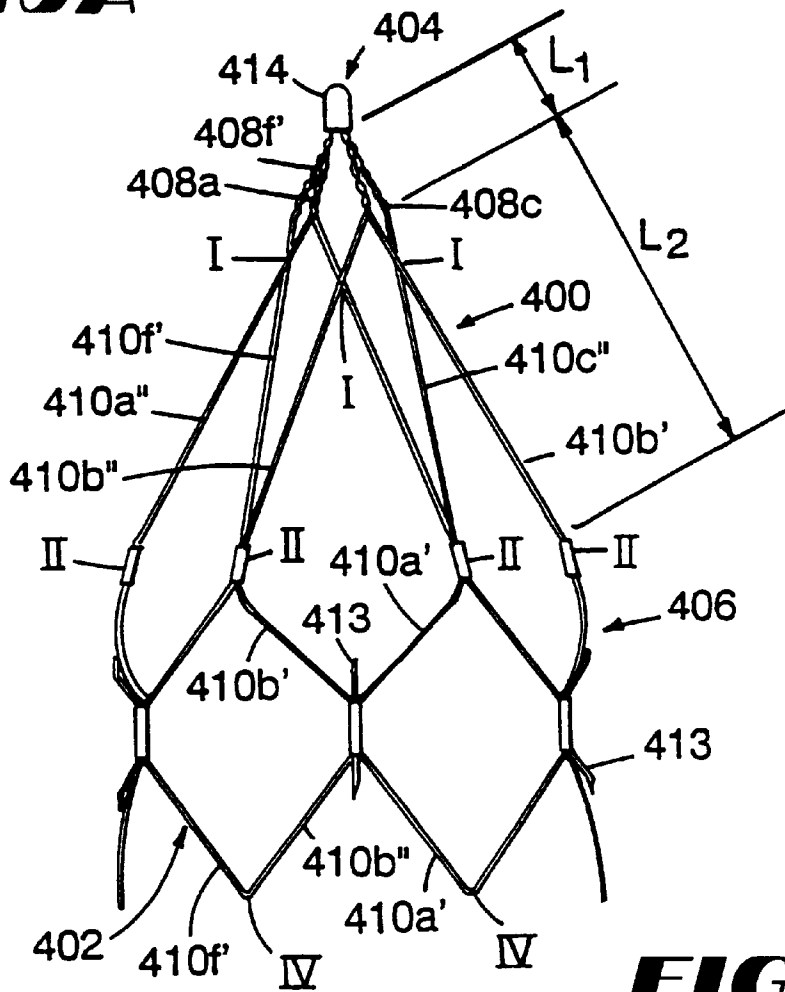
**FIG 9**



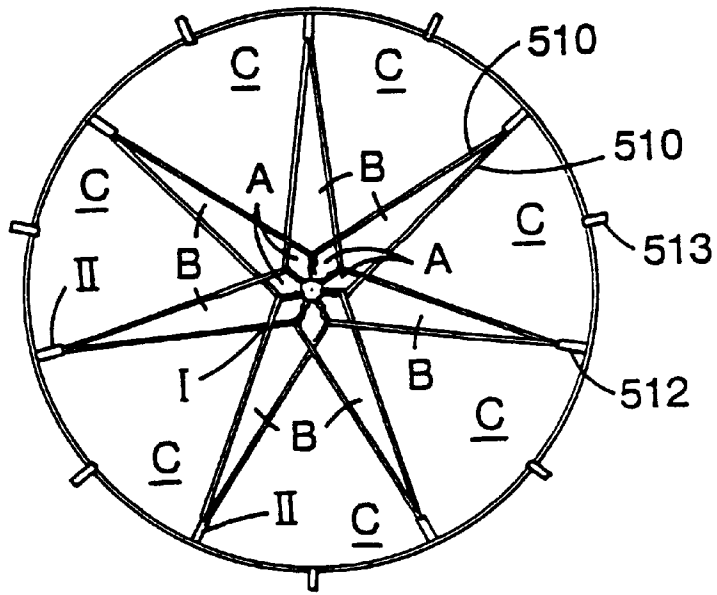
**FIG 9A**



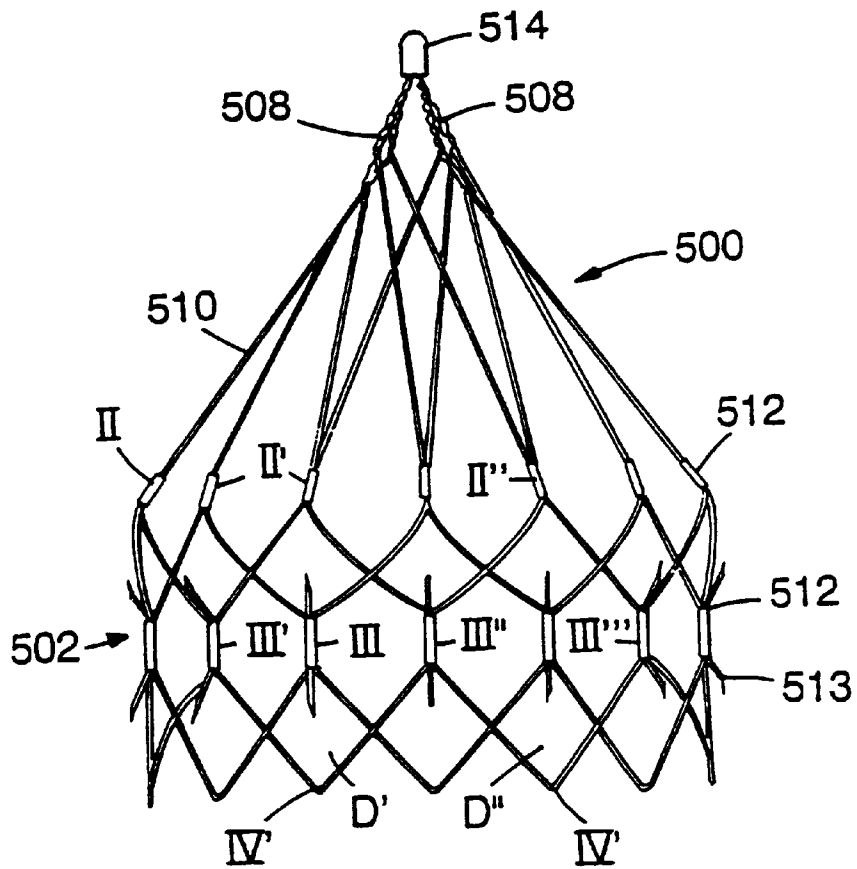
**FIG 10A**



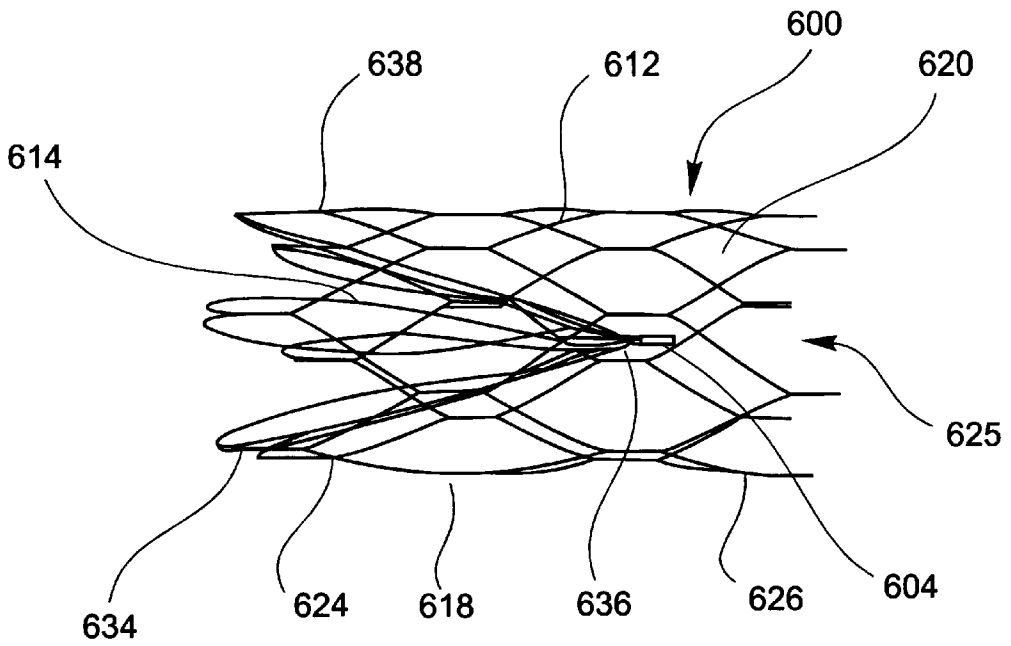
**FIG 10**



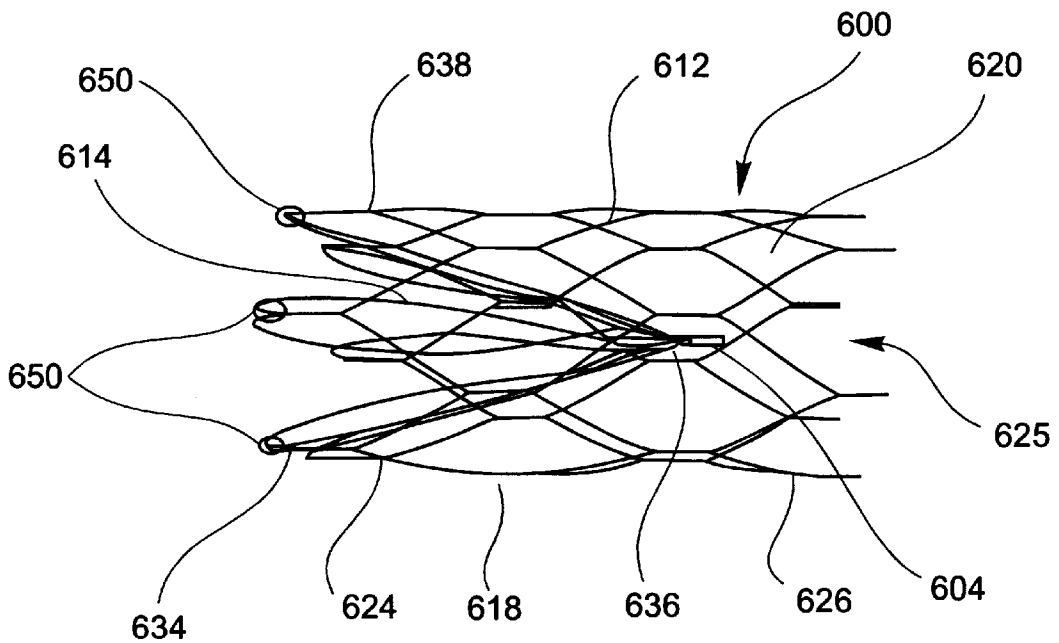
**FIG 11A**



**FIG 11**



**FIG 12 A**



**FIG 12 B**

US 6,214,025 B1

1

**SELF-CENTERING, SELF-EXPANDING AND RETRIEVABLE VENA CAVA FILTER**

This application is a continuation-in-part application of Ser. No. 08/849,392 filed Nov. 10, 1997, now U.S. Pat. No. 6,013,093, which is a continuation-in-part of Ser. No. 08/346,733 filed Nov. 30, 1994, issued as U.S. Pat. No. 5,709,704 on Jan. 20, 1998.

**FIELD OF THE INVENTION**

This invention relates to blood clot filtering.

**BACKGROUND OF THE INVENTION**

Blood clots that form in the lower part of the body may migrate to the heart and may be subsequently pumped to the lungs. Small clots can be absorbed by the body without adverse effect. However, larger clots (e.g., on the order of 3 mm in diameter and 10–30 cm in length) can interfere with the oxygenation of blood and can possibly cause shock or sudden death.

Many transvenous filtering devices have been developed for installation in the vena cava to prevent especially large clots from reaching the lungs. These filters have fine wires positioned in the blood flow to catch and hold clots for effective lysing in the blood stream. Some of these devices are inserted into the vena cava by dissecting the internal jugular vein in the neck or the femoral vein in the groin, inserting a metallic capsule containing a filtering device to the proper position in the vena cava, and releasing the filtering device into the vena cava. More recently, filters have been designed for percutaneous introduction into the vasculature.

U.S. Pat. No. 5,344,427 discloses a filter including extending wire portions folded in the shape of a hairpin into a plurality of resilient triangular fingers. The particular shape of the triangular fingers is meant to enable the wire portions to be moved together easily, for example, for radially contracting the filter for delivery within a vessel. With such a design, however, the finger portions can “bunch up” in a non-symmetrical pattern around the circumference of the device, and can cause improper spacing of the filter element within a vessel.

**SUMMARY OF THE INVENTION**

In one aspect, the invention features a filter sized and constructed to be compressed and passed through the vasculature of a patient to be anchored against an inner wall surface of a blood vessel for capturing blood clots in a blood stream passing therethrough. The filter comprises: an anchoring portion comprising a generally cylindrical self-expanding body formed from resilient material, the generally cylindrical body having proximal and distal ends and defining an axial direction and having a structure of variable size diameter expandable from a low-profile compressed condition to a larger profile expanded condition, wherein the resilient material urges the generally cylindrical body to radially expand and to thereby apply anchoring radial force against the inner wall surface of the blood vessel; and a generally conical filtering portion axially aligned with the generally cylindrical body having an open proximal end coupled to the distal end of the anchoring portion and having an apical distal end. In such an embodiment, the anchoring portion and the filtering portion are substantially nonoverlapping to achieve a low profile compressed condition for delivery of the filter through the vasculature.

2

In a further embodiment, the present invention includes a blood clot filter including an anchoring portion having a generally cylindrical radially expandable body with proximal and distal ends and an axial lumen extending therethrough, with the anchoring portion defining a plurality of closed cells forming a series of circumferential rings. The blood clot filter further includes a filtering portion having a generally conical body concentrically aligned within the axial lumen of the anchoring portion, with the conical body including an open proximal end adjacent the distal end of the anchoring portion and being tapered to form a distal tip. In such an embodiment, the anchoring portion and the filtering portion may be discrete portions fixedly attached at their proximal ends, or may be formed from a single piece of material with the anchoring portion being contiguous with the filtering portion.

Embodiments of the invention may include one or more of the following features. The generally conical filtering portion is preferably formed from a plurality of elongated strands arranged to form a generally conical structure to guide blood clots in the blood stream flowing therepast to the apical distal end of the generally conical filtering portion for lysing. The elongated strands forming the generally conical filtering portion are constructed and arranged to maintain a generally conical shape whether the anchoring portion is in a compressed condition or an expanded condition. The anchoring portion and the filtering portion are preferably constructed and arranged so that the proximal end of the filtering portion conforms to the shape of the cylindrical body of the anchoring portion. The elongated strands are preferably fixedly attached to one another only at the apex of the generally conical filtering portion. The elongated strands may be formed from nitinol (nickel-titanium alloy), plastically deformable material, temperature-sensitive shape memory material with a transition temperature around body temperature, or elastic material having a core formed from radiopaque material. The filter may be coated with a drug for in vivo compatibility. The resilient elongated strands preferably extend from the proximal end of the anchoring portion to the distal apical end of the filtering portion.

The elongated strands of the filtering portion may define a plurality of neighboring filtering cells. According to one embodiment, the neighboring filtering cells are preferably loosely coupled together at the respective areas of contact between neighboring cells. The neighboring cells are preferably coupled together by helical twisting of portions of respective elongated strands of neighboring cells. The portion of the twisted-together elongated strands are preferably capable of slight mutual separation to accommodate changes in the shapes of the cells from the expanded to the compressed conditions.

According to another embodiment, the strands cross one another and are slidably movable relative to each other at their crossing regions.

The generally conical filtering portion preferably comprises at least two rings of cells, wherein the cells of each ring are of substantially equal size and are spaced substantially the same distance from the apical distal end of the filtering portion. The size of the cells in the rings is preferably smaller for cells closer to the apical distal end of the filtering portion than for cells located a greater distance from the apical distal end of the filtering portion.

The elongated strands may be twisted together in twisted groups of strands that converge at the apical distal end of the filter portion. The strands forming each twisted group may diverge from the twisted group and extend in paths there-

US 6,214,025 B1

3

from to the open proximal end of the filter portion. Preferably, the twisted groups are twisted pairs of strands that diverge in either straight paths or spiralling paths that cross one another.

The elongated strands of the filtering portion may be spirally arranged with respect to one another from the proximal end of the filtering portion to the apical distal end of the filtering portion.

The elongated strands are preferably selected to have sufficient rigidity to maintain the generally conical shape of the filtering portion.

The self-expanding anchoring portion preferably comprises a ring of neighboring cells. The cells of the anchoring portion are preferably self-expanding. The cells of the anchoring portion preferably cooperate to urge the generally cylindrical body of the anchoring portion to radially expand from a compressed condition to an expanded condition. The neighboring cells of the anchoring portion are preferably fixedly coupled together at respective areas of contact. The cells of the anchoring portion are preferably formed from one or more resilient elongated strands. When the generally cylindrical body is in a compressed condition, the cells of the anchoring portion are preferably elongated in the axial direction.

In another general aspect, the invention features a blood clot filter comprising: an anchoring portion formed from resilient material having proximal and distal ends and having a generally circular transverse cross-section defining an axial direction, the anchoring portion further having a structure of variable size diameter expandable from a low-profile compressed condition to a larger profile expanded condition, wherein the resilient material urges the anchoring portion to radially expand and to thereby apply anchoring radial force against the inner wall surface of the blood vessel; a filtering portion axially aligned with the generally cylindrical body having an open proximal end coupled to the distal end of the anchoring portion; and one or more hooks fixedly coupled to the anchoring portion formed from compliant material having an original shape that bends under stress yet returns to its original shape when unstressed, said one or more hooks respectively tending to project from the anchoring portion at an acute angle with respect to the axial direction for engagement with a vessel wall, the one or more hooks further being deflectable toward the anchoring portion for achieving a low-profile.

Embodiments of the invention may include one or more of the following features. The hooks are preferably formed from nitinol. The hooks preferably preferentially bend toward and away from the vessel wall engaging portion. The hooks are preferably formed from flat nitinol wire having a width dimension and having a thickness dimension substantially smaller than the width dimension for achieving preferential bending; the flat nitinol wire being oriented so that the thickness dimension of the flat nitinol wire coincides with a radial direction of the anchoring portion. The hooks preferably preferentially bend toward and away from the vessel wall engaging portion.

Among the advantages of the present invention are the following. Because the anchoring portion and the filtering portion have constructions that are optimally designed for their respective functions, the filter can have a low profile while providing a robust design that can readily accommodate different vessel sizes. Furthermore, the anchoring portion serves to center the filtering portion. The filtering portion of the filter should have a small enough capture cross-section to prevent large clots from passing there-

4

through. This requires a sufficient amount of filtering material (e.g., elongated strands) to reduce the capture cross-section. Since the conical filtering portion according to the present invention does not also have to support the filter in the vessel, smaller-sized elements can be used to form the filter to achieve a lower profile. The profile of the present invention can be made small, while providing substantially the same anchoring force and substantially the same filtering efficiency as, e.g., a GREENFIELD® 24 Fr stainless steel filter (available from Medi-Tech, Inc. of Watertown, Mass., U.S.A.). The filter designs minimally disturb blood flow, while achieving a desirable level of filtering efficiency. Since the sizes of the cells of the filtering portion decrease from the proximal end to the distal end, larger cells are positioned near the vessel walls where the flow velocity is relatively low and smaller cells are positioned in the central region of the vessel where the flow velocity is highest and where the most effective clot lysing occurs. Without being limited to a particular theory, it is believed that clots traveling with lower velocity do not pass through the larger size cells in the periphery of the conical filtering portion, but are instead guided to the apical distal end of the filtering portion. Clots traveling with higher velocities in the central region of the vessel, which may otherwise pass through the larger size peripheral cells, are caught in the smaller size cells located at the distal end of the filtering portion. Because the radial force against the vessel wall is distributed along a length of the vessel wall a filter according to the present invention offers higher resistance to migration as well as less trauma to the vessel wall.

Other features and advantages will become apparent from the following description and from the claims. For example, the invention features a process for making a blood clot filter and a method for treating a patient by implanting a blood clot filter into a blood vessel of the patient.

#### BRIEF DESCRIPTION OF THE DRAWING

FIGS. 1 and 1A are diagrammatic side and end views of a filter in an expanded condition. FIGS. 1B and 1C are enlarged views of respective portions of the filter shown in FIG. 1.

FIGS. 2 and 2A are diagrammatic side and end views of a filter in a compressed condition. FIG. 2B is an enlarged view of a portion of the filter of FIG. 2.

FIG. 3 is a plot of radial expansion force provided by a filter as a function of the outer diameter of the filter. FIG. 3A is a diagrammatic side view of a system for measuring the radial force exerted by a filter as a function of the outer diameter of the filter.

FIGS. 4-4A are diagrammatic side views of a filter and forming mandrels at different stages in a process for fabricating the filter shown in FIGS. 1-1B and 2-2B.

FIG. 5 is a diagrammatic side view of a filter being delivered to a blood vessel. FIG. 5A is a diagrammatic side view of a filter anchored in a blood vessel.

FIGS. 6 and 6A are diagrammatic side and end views of a filter. FIG. 6B is an enlarged view of a portion of the filter shown in FIG. 6.

FIGS. 7 and 7A are diagrammatic side and end views of a filter.

FIG. 8 is a diagrammatic side view of a filter. FIGS. 8A and 8B are diagrammatic end views of the filter of FIG. 8 in an expanded condition and in a compressed condition, respectively.

FIGS. 9 and 9A are diagrammatic side and end views of a filter in an expanded condition.

US 6,214,025 B1

5

FIGS. 10 and 10A are diagrammatic side and end views of a filter in an expanded condition.

FIGS. 11 and 11A are diagrammatic side and end views of a filter in an expanded condition.

FIGS. 12A and 12B are diagrammatic side views of a filter according to an alternate embodiment of the present invention.

#### DETAILED DESCRIPTION OF THE INVENTION

Referring generally to FIGS. 1–1C and 2–2B, a blood clot filter 10 includes a generally cylindrical anchoring portion 12 and a generally conical filtering portion 14 terminating at a closed, distal apical end 6. The cylindrical portion uniformly exerts an outward radial force to anchor the filter in a blood vessel (e.g., the vena cava) in which it is disposed; the exerted force being sufficient to prevent migration of the filter in the vessel. The generally cylindrical shape of the anchoring portion conforms to the inner wall surface of a blood vessel and properly centers the filtering portion within the vessel. The filtering portion provides a conical mesh-work across the blood vessel to catch and retain clots in the blood stream.

Cylindrical portion 12 is formed by a ring 18 of circumferentially arranged cells 20. Filtering portion 14 is formed by a series of three rings (22, 24, 26) of relatively loosely connected cells (28, 30, 32, respectively). The size of the cells forming the rings of the filtering portion increases from apical end 16 of the filtering portion to the proximal end 34 of the filtering portion, which is adjacent the distal end 36 of the anchoring portion.

Cells 20 of the cylindrical portion of the filter are defined by elongated strands 38 of resilient material (e.g., nitinol wire). Neighboring cells are fixedly joined together at respective regions of contact 40, e.g., by spot welding, as described in detail below. Fixed regions of contact 40 enable cells 20 in ring 18 to cooperate to urge the anchoring portion into an expanded condition (FIGS. 1–1B). The fixed regions of contact 40 also prevent the elongated strands forming cells 20 from rotating about each other, which might cause hinging and locking between the cells in a manner distorting the cylindrical shape of the anchoring portion. In a compressed condition (FIGS. 2–2B) the longitudinal length of cylindrical anchoring portion 12 increases.

Conical filtering portion 14 is constructed from a series of rings (22, 24, 26) of relatively loosely coupled cells in a manner preserving its generally conical shape, whether the filter is in a compressed condition or an expanded condition. The filtering portion does not need to provide anchoring radial force. However, the material substance forming the conical structure has sufficient structural integrity to prevent large clots in the blood flow from displacing the filtering structure. The size of the cells in the filtering portion are selected to minimally disturb the blood flow (which would otherwise encourage occlusion of the vessel), while still achieving a desired level of blood clot filtering.

In the embodiment shown in FIGS. 1–1C and 2–2B, the cells forming the filtering portion are coupled together by helically twisting together respective portions of the elongated strands defining neighboring cells. This coupling permits some rotation about the joints in a manner that preserves the generally conical shape of the filtering portion, whether the filter is in a compressed condition or an expanded condition.

Comparing FIGS. 1B and 2B, in the expanded condition (FIG. 1B), the twisted wire portions 52, 54, coupling neigh-

6

boring cells in the filtering portion of the filter, are tightly wrapped about each other. However, in a compressed condition (FIG. 2B), wire portions 52, 54 move away from (and rotate about) one another to form gaps 56. This rotation or hinging prevents the build-up of internal forces within the filtering portion, which could cause the filtering portion to bow outward into a hemispherical shape, which would result in less effective blood clot filtering.

Referring back to FIG. 1C, a hook 44 formed from a section of flat nitinol wire is disposed within a tube 46 (e.g., a hypotube) and mounted at regions of contact 40 between neighboring cells in ring 18, which forms the cylindrical portion of the filter. A central region of hook 38 is mounted at regions of contact 40. Hook 44 is bent at its proximal and distal ends to respectively form acute angles 48, 50 with respect to the longitudinal axis of the cylindrical portion. The bent ends of hook 44 are oriented in divergent direction to prevent migration of the filter in proximal and distal directions. The nitinol hooks easily bend to conform to the shape of the cylindrical surface of the anchoring portion to achieve a low profile for delivery of the filter. When the filter is released into a blood vessel, the hooks return to their bent shape for engaging an inner wall surface of the vessel. Fewer hooks may be used (e.g., three hooks symmetrically disposed about anchoring portion 12 may be used) to achieve a lower profile for delivery of the filter.

In a presently preferred embodiment designed for filtering blood clots in a vena cava of about 28 mm diameter, cylindrical portion 12 includes six cells formed from nitinol wire of 0.002–0.01 inch diameter, and preferably 0.008 inch diameter (e.g., nitinol with an  $A_f$  between  $-10^\circ\text{C}$ . and  $+5^\circ\text{C}$ . and constructed so that after drawing the wire has a tensile strength of about 250,000 psi to 300,000 psi, available from Shape Memory Applications of Sunnyvale, Calif, U.S.A.). Each cell in the anchoring portion has four side portions about 13 mm in length. Filter 10 is collapsible to a diameter of 0.08 inch (about 6 Fr). The anchoring portion has an expanded outer diameter of 30–31 mm.

The filtering portion includes three rings of cells of decreasing size from the proximal end 34 to the distal apical end 16. Each of the proximalmost cells in the filtering portion has four side portions: two proximal side portions about 13 mm in length and two distal side portions about 15 mm in length. Each of the intermediate cells in the filtering portion has four side portions: two proximal side portions about 15 mm in length and two distal side portions about 11 mm in length. Each of the distalmost cells of the filtering portion has four sides portions: two proximal side portions about 11 mm in length and two distal side portions about 9 mm in length. The total length of the filter in the expanded condition is about 60 mm, with the filtering portion being about 32–34 mm in length and the anchoring portion being about 26–28 mm in length. Six hooks 44 are symmetrically disposed about the anchoring portion at each of the fixed regions of contact 40. Hooks 44 are made from flat nitinol wire about 5 mm in length, about 0.5 mm in width and about 0.05–0.15 mm thick.

Referring to FIG. 3, the outward radial expansion forces respectively exerted by six different filters of the type shown in FIGS. 1–1C and 2–2B are plotted as a function of the outer diameter of cylindrical portion 12. The measured filters were designed with the specifications recited above. The exerted force generally varies linearly with the diameter of the anchoring portion, with the highest forces being exerted when the filter is in the lower profile conditions (i.e., most compressed). Force levels of 0.01–0.07 pounds are generally acceptable for a typical vena cava of 12–28 mm



US 6,214,025 B1

7

diameter. Much higher force levels may cause the filter to undesirably distort the shape of the vena cava. Also, much lower force levels would not securely anchor the filter in the vena cava and the filter may be displaced.

The number of cells in the anchoring portion and in the filtering portion may be varied to achieve larger sizes or higher forces. For example, to accommodate a so-called "mega-cava" having a diameter of up to 40 mm, the expanded outer diameter of the filter should be selected to be about 42–44 mm and the number of cells in the anchoring portion should be appropriately increased (e.g., nine cells could be used) to achieve proper outward radial force exertion to anchor the filter in the vena cava without migrating or traumatizing the vessel. Instead of increasing the number of cells, the thickness of the wire used to form the cells could be suitably increased to provide the proper amount of anchoring force. Alternatively, the exerted radial force may be increased by providing additional welds at the distal end **36** (FIG. **1**) of the anchoring portion at locations **126**. This increases the structural integrity of each cell **20**, providing higher spring force under compression. The exerted radial force may alternatively be increased by changing the wire alloy or the degree of cold work.

Referring to FIG. **3A**, the outward radial force exerted by a filter was measured using a force gauge **70** (e.g., a Chattillon gauge) attached to one half **72** of a solid block **74** through which cylindrical hole **76** of a preselected diameter is disposed. Block **74** was cut in half through a plane containing the longitudinal axis of cylindrical hole **76**. A filter to be measured was placed in hole **76**. A micrometer **80** attached to the other half **82** of block **74** was used to close the gap between the two halves of block **74**. The force exerted by the filter was measured as a function of filter diameter by performing the measurement with a series of blocks with different preselected diameters.

Referring to FIGS. **4** and **4A**, in a process for fabricating a filter **10**, a cylindrical thermally conductive mandrel **90** (e.g., formed from copper) is sized and constructed to conform to the desired filter size and shape. Mandrel **90** includes a plurality of anchoring pins protruding from its outer surface in a pattern corresponding to the desired cellular pattern for the filter.

As shown in FIG. **4**, the process for fabricating the anchoring portion of the filter includes the following steps. A wirestrand **98** is bent around an anchoring pin **100** to form the proximal end of anchoring portion **12** of the filter. The two ends of wire strand **98** are pulled divergently downward to pins **102**, **104** and through respective hypotubes **106** and **108**. The strands are bent convergently further downward to pin **110** (located about 23 mm distally from anchoring pin **100**), below which they are helically twisted about each other through two turns. The same steps are performed for neighboring strands **112** and **114**. Hooks **116**, **118** are also passed through hypotubes **106**, **108**. The respective hypotube assemblies are joined by resistance welding under an inert gas shield using about 70 ounces of force and about 10 Joules of heat.

As shown in FIGS. **4A**, the process for fabricating the filtering portion includes the following steps. The previously formed anchoring portion **12** of the filter is positioned about a cylindrical portion **92** of a mandrel **93** (e.g., formed from aluminum or stainless steel), which includes a conical portion **94**. The ends of strand **98** are pulled divergently downward to pins **120**, **122** (located about 22 mm proximally from the distal end **123** of mandrel **91**), below which the strands are helically twisted through two turns with

8

respective ends of neighboring strands **112**, **114**. The ends of strand **98** are convergently pulled further downward to pin **124** (located about 8 mm proximally from the distal end **123** of mandrel **91**), below which the ends of strand **98** are helically twisted about each other through about 4–7 turns to the apical distal end of the filtering portion. The resulting six pairs of helically twisted strands are passed through a short hypotube (not shown), the top of which is TIG welded-to securely fix all of the strands.

A metallic wire is wrapped about the filter/mandrel assembly to tightly secure the relative positions of the elongated wire strands defining the cells in the anchoring and filtering portions. The filter and the forming mandrel are then placed in an oven set to a temperature of about 450° C. for a period of 15 to 20 minutes. Prior to this heat treatment the nitinol wires are relatively malleable, but after heat treatment the nitinol wires strands preferentially maintain their shape. Once the mandrel has cooled the anchoring pins are removed and the filter is removed from the mandrel.

Referring to FIGS. **5** and **5A**, a blood clot filter **10** is delivered to a desired location within a vessel **130** (e.g., a vena cava having a diameter on the order of about 20 mm) through a previously inserted teflon sheath **132**. Sheath **132** having an outer diameter on the order of about 3 mm is inserted percutaneously, e.g., via a small opening (on the order of 9 Fr (about 0.117 inch)) in the groin and into the femoral vein of a patient. A pusher **134**, extending proximally to a location outside of the patient, is used to advance filter **10** through the sheath. Once the distal end of the sheath is properly positioned in vessel **130**, pusher **134** advances filter **10** to the distal end of the sheath and holds filter **10** in the desired position in the vessel. The sheath is then pulled back, releasing the filter within vessel **130**, as shown in FIG. **5A**. Once the filter is released, the sheath and the pusher can be withdrawn from the patient as a single unit.

Referring to FIG. **5A**, after the filter is released within vessel **130**, the self-expanding cells of the anchoring portion urge the anchoring portion to outwardly expand against an inner wall surface **136** of vessel **130** with sufficient force to prevent migration of the filter through the vessel. Within sheath **132** hooks **44** lie flat and conform to the shape of the cylindrical portion to allow the filter to slide through the sheath, but when the filter is released from the sheath the hooks spring outwardly from the anchoring portion of the filter for engagement with wall surface **136**. The expansion of the anchoring portion imbeds hooks **44** into the walls of the vessel to further secure the filter within the vessel.

We note that FIGS. **5** and **5A** are not drawn to scale, but instead are drawn diagrammatically for purposes of illustration.

In operation, the filter captures a blood clot **138** in blood flow **140** (e.g., on the order of 1 liter per minute) by guiding the clot to the apical distal end **16** of the filtering portion. Captured clots **142** are maintained in the central region of the blood flow where the velocity is highest to achieve the most effective lysing action.

As mentioned above, the sizes of the cells in the filtering portion are selected to be small enough to capture clots of a specified size with a desired level of efficiency (e.g., with clot capturing efficiency and patency comparable to a GREENFIELD® 24 Fr stainless steel filter, available from Medi-Tech, Inc. of Watertown, Mass., U.S.A.). Thus, it is desirable to reduce the size of the cells to increase the efficiency of clot capture. However, smaller cells create greater turbulence in the blood flow, encouraging clot formation on the filter that may result in the occlusion of a

US 6,214,025 B1

9

vessel. A filter according to the invention minimally disturbs blood flow, while achieving a desirable level of filtering efficiency. The sizes of the cells in the filtering portion decrease the closer they are to the apical distal end 16. Thus, cell size in the filtering portion varies inversely with blood flow velocity: larger cells are positioned near the vessel walls where the flow velocity is relatively low and smaller cells are positioned in the central region of the vessel where the flow velocity is highest. Clots traveling with lower velocity do not pass through the larger size cells in the periphery of the conical filtering portion, but are instead guided to the apical distal end of the filtering portion. Clots traveling with higher velocities in the central region of the vessel, which may otherwise pass through the larger size peripheral cells, are caught in the smaller size cells located at the distal end of the filtering portion.

Other embodiments are also encompassed by the invention. Referring to FIGS. 6-6B, a blood clot filter 150 includes a generally cylindrical anchoring portion 152 and a generally conical filtering portion 154. Anchoring portion 152 includes a ring of cells 156 and is constructed in a similar manner as anchoring portion 12 of filter 10, shown in FIGS. 1-1C and 2-2B. Filtering portion 154 is formed from six spirally arranged legs 158 terminating at an apical distal end 160.

Legs 158 of the filtering portion of the filter are twisted through 90° over a length of about 32-34 mm. Twisting legs 158 creates a series of spirally arranged cells 162. The projection of legs 158 in a plane transverse to the longitudinal axis of the anchoring 35 portion reveals that the cells defined by legs 158 decrease in size from the peripheral edge of the filtering portion to the apical center; the amount of reduction being determined by the twist pitch (degrees of rotation per unit length) and the number of legs 158 in the filtering portion. This reduction in cell size achieves an advantage similar to the advantage achieved by the reduction in cell size in the embodiment of FIGS. 1-1C and 2-2B, as described above.

As shown in FIG. 6B, legs 158 are formed from pairs of elongated strands of resilient material (e.g., nitinol wire) 164, 166 helically twisted about each other. Strands 164, 166 correspond to the respective ends of strands 168 that are bent into a V-shape to form the proximal end of anchoring portion 152. Twisting strands 164, 166 increases the rigidity of legs 158 for maintaining the structural integrity of the generally conical filtering portion. Increasing the rigidity of legs 158 also prevents clots from forcing their way past the filter by displacing the relative positions of the legs.

Referring to FIGS. 7-7A, in another filter embodiment 170, a generally cylindrical anchoring portion 172 is constructed in a similar manner as anchoring portion 12 of filter 10, shown in FIGS. 1-1C and 2-2B. A generally conical filtering portion 174 is formed from six spirally arranged legs 176 terminating at an apical distal end 178.

Legs 176 of filtering portion 174 are twisted through 90° over a length of about 32-34 mm, as in the filter embodiment shown in FIGS. 6-6B, creating a ring of spirally arranged cells 180. However, each leg 176 is formed from the continuation of a single elongated strand (formed from, e.g., nitinol wire) from the anchoring portion. To increase the structural integrity of the anchoring portion and the filtering portion, a series of spot welds 182 are provided at the distal end of the anchoring portion, joining strands 184, 186 that define cell 188.

As shown in FIGS. 8-8B, the anchoring portion 190 of a filter 192 may be formed from flat strands 200 (e.g., formed

10

from superelastic material such as nitinol wire) having a rectangular cross-section. The anchoring portion of the filter is shown in an expanded condition in FIG. 8 and in a compressed condition in FIG. 8A. The flat strands are arranged in the form of a ring of cells 202 (e.g., six cells), with the number and size of the cells being selected to provide a desired level of anchoring force. The width dimension 204 (on the order of 0.5-0.7 mm wide) of flat strands 200 is oriented radially and the thickness dimension 206 (on the order of 0.05-0.15 mm thick) is oriented circumferentially. This strand orientation provides a high radial force-to-compressed profile ratio. Also, use of flat strands facilitates manufacture of the filter because there is more strand material available for welding. A filtering portion 194 (e.g., a conical filtering portion) may be formed from spirally arranged wires as shown or may be formed from rings of cells, as in the filter of FIG. 1. The filtering portion may be formed from the extension of flat strands 200. Alternatively, a filtering portion may be formed from round wire that may be joined to the flat strand anchoring portion by welding with a hypotube arranged as a universal-type hinge, or by using an adhesive or sutures.

Referring now to FIGS. 9-9A, another embodiment of a self-expanding filter, illustrated in an expanded condition, includes a substantially conical-shaped filter portion 300 that has a central apex 304 at one end and is joined at its other, open end 306 to an end of a cylindrical-shaped anchoring portion 302. In the expanded condition, the open end of the filter portion is about 30-31 mm in diameter, and the filter portion has a mean length that is between about 30-40 mm.

Six pairs 308 of twisted strands 310 of resilient nitinol wire extend in a mutually twisted relationship from the apex 304 of the filter for a first distance L. Some of the strands 310 are hidden in the figures. The wire is preferably about 0.008 inches in diameter, and L can be between 0.2-0.5 inches and is preferably approximately 0.25 inches. The twisted pairs 308 diverge from each other as they spread from the center in paths substantially along the surface of an imaginary cone.

At the end of distance L, the strands 310 of each twisted pair 308 diverge from each other in opposite spirals. Strands 310, spiralling in a first sense, are indicated in FIGS. 9 and 9a by a single prime mark ', and strands spiralling in the opposite sense are indicated with a double prime mark ". The pairs of component strands 310 forming each of the twisted pairs 308 are distinguished by letters a-f.

The strands 310 continue along the surface of the imaginary cone, until adjacent strands cross each other at crossing regions, or nodes I. Each of a first ring of six open, generally diamond-shaped cells, A, is thereby defined. On two sides next to the center cells A are defined by adjacently located twisted pairs 308, and on the two more distant sides by oppositely spiralling individual strands 310 that cross at nodes I. Each cell A shares a side formed from a twisted pair 308 with an adjacent cell A.

The strands 310 cross in an overall woven relationship at nodes I. Strand 310a' crosses over strand 310b", whereas at the next laterally adjacent node I, strand 310b' crosses over strand 310c", and so on, alternating about the central axis of the filter. The woven relationship establishes a slidable engagement of the crossing strands 310, permitting the strands to slide relative each other at the nodes I during radial compression or expansion of the filter.

From nodes I the strands 310 continue in their generally spiralling relationship, progressing along the general surface of the imaginary cone. The strands 310 reach and cross

US 6,214,025 B1

11

further oppositely spiralling strand **310** at nodes II. The strands **310** again cross in a woven, slidable relationship such that each strand **310** that passed under a strand **310'** at a node I now crosses over a different one of strands **310'** at a node II.

A second ring of six open, four-sided cells B that are each larger than cells A is thus defined adjacent cells A. Each cell B shares two short sides, located closest to the apical center **304**, with two adjacent cells A, and shares a node I with an adjacent cell B on each laterally spaced corner. The two short sides of each cell B are formed from strands **310** diverging from one of the twisted pairs **308**. For example, strands **310a'** and **310a''** form two sides of one of cells B, strands **310b'** and **310b''** form two sides of the next adjacent cell B, and so on. Two other, longer sides of each cell B are formed from oppositely spiralling strands diverging from the next adjacent twisted pairs **308**. For example, strands **310b''** and **310b'** form the long sides of one of cells B that has short sides formed from strands **310a'** and **310a''**.

The strands **310** continue spiralling from nodes II until they reach joints at a third set of nodes III. A third ring of six open, four-sided cells C, each larger than cells B and A, is thus formed. A corner of each cell C closest the apical center of the filter portion is defined by one of nodes I. Two other corners farther from the apical center are formed from laterally adjacent nodes II. The fourth corner of each cell C is formed from one of nodes III. Two sides of each cell C closest to the apical center are formed by strands **310** that form adjacently located long sides of two adjacent cells B, for example strands **310c''** and **310b'**. Strands forming the two other long sides of the two adjacent cells B, in this instance strands **310a'** and **310d''**, continue past nodes II to form two sides of that cell C farther from the apical center **304**. While strands **310** joined at nodes III are not free to move relative to one another, strands **310** crossing at the other corners of cells C, at nodes I and II, are slidable relative to each other.

Strands **310** diverge from nodes III, although not in a spiralling fashion. For example, strands **310a'** and **310d''** diverge at node III and then join with strands **310c''** and **310b'**, respectively, at nodes IV. A fourth ring of four-sided, open cells D is thereby formed, that are larger yet than cells A, B or C and lie close to parallel with the direction of flow Z. The strands forming each of cells D are fixed together where they cross at two nodes III and one node IV, but are slidable relative to each other at one node II.

The strands connecting between nodes III and IV define the open end **306** of the conical filter portion **300**. These strands **310** also form a boundary for one end of the anchoring portion **302**. The anchoring portion **302** is formed of a fifth ring of six diamond-shaped, open cells E, that lie along the inner wall of the blood vessel, parallel to the direction of blood flow. In the expanded configuration, the anchoring portion **302** is preferably approximately 25 mm long and approximately 30–31 mm in diameter.

Strands forming two sides of each cell D that are farthest from the apical center **304** also form sides of two adjacent cells E. The strands diverge at nodes IV and intersecting strands are joined again at nodes V. In the preferred embodiment shown in FIG. 9, for example; strands **310a'** and **310d''** diverge from node III, are joined to strands **310c''** and **310b'**, respectively at adjacent nodes IV, and diverge from nodes IV and are joined again at node V, which, in this embodiment, is actually a bend in a single strand. In some applications, it may be desirable to form a longer anchoring portion by simply forming one or more additional rings of diamond-shaped, open cells that lie along the lumen wall.

12

Strands **310** are joined at nodes III and IV by positioning a small cylindrical sleeve **312** around a pair of strands and then by welding or crimping the sleeve **312** to the strands. The twisted pairs **308** are joined where they converge at the apex **404** by positioning a sleeve **314** over them and then welding or crimping the pairs **308** and the sleeve together.

Hooks **313** are coupled to the anchoring portion **302** at nodes IV for engaging the inner wall of a blood vessel such that the filter will not slip out of position once emplaced.

The structure of cells A, defined by the twisted pairs **308** in the region adjacent to the center **304** of the filter portion **300**, achieves an open area that is relatively large in the central region of greatest blood flow rate in comparison to the case that would exist if the same number of strands **310** commenced their independent spiralling at the center of the filter unit **300**. The relatively open geometry obtained by twisting the strands **310** into pairs **308** before joining them at the center **304** enhances blood flow and clot-lysing action and reduces any tendency for forming new clots on the filter.

The relatively large openings of cells A, and the progressively larger cells B, C and D, while providing a relatively low flow resistance, are small enough to capture clots effectively, given the respective aspect angles that they present to the flow.

Each filter cell A, B, C and D in this embodiment has at least one node formed by crossing strands that can slide relative to each other when the filter is radially or longitudinally deformed. Cells B and C intermediate the extremities of the conical structure have such slidable engagement at three nodes.

The strands **310** spiral in gently arcuate paths between the twisted pairs **308** and nodes III. There are no sharp bends in the strands where they cross at nodes I or II. This feature enhances the ability of the strands **310** to slide relative to each other at their crossing regions. The woven, crossing, and slidable relationship of the strands **310** at the nodes I and II in this embodiment produces a structural integrity sufficient to maintain the desired conical structure and filtering aspect, while having a degree of sliding self-adjustability when compressed or expanded that contributes to the filter's ability to conform to various size vessels.

Referring now to FIGS. 10 and 10A, another embodiment of a self-expanding filter, illustrated in an expanded condition, includes a substantially conical-shaped filter portion **400** that has a central apex **404** at one end and is joined at its other, open end **406** to an end of a cylindrical-shaped anchoring portion **402**. Like the filter illustrated in FIGS. 9 and 9A, this filter is about 28–30 mm in diameter in the expanded condition and the filter portion is about 30–40 mm long.

Six twisted pairs **408a–f** of elongated strands **410** of nitinol wire extend from the apex for a distance  $L_1$  along the surface of an imaginary cone. The strands **410** forming each twisted pair **408** then diverge from each other at an angle and continue toward the open end **406** in approximately straight paths along the surface of the imaginary cone. Some of the strands **410** and twisted pairs **408** are hidden in the figures. The strands are referenced by letters a–f to indicate the twisted pairs from which they respectively originated.  $L_1$  can range between about 0.2–0.5 inches, and is preferably about 0.25 inches.

A first group of the strands **410** that diverge from the twisted pairs **408** in one direction, indicated by a single prime ', each cross under a strand **410** from an adjacent twisted pair **408** that diverges in the other direction, the second group of strands being indicated by a double prime ''

US 6,214,025 B1

13

". For example, strand **410a'** crosses over strand **410b''**, strand **410b'** crosses under strand **410c''**, etc. The strands **410** are slidably movable relative to each other at the crossing regions, or nodes I, during expansion and compression of the filter.

A first ring of six diamond-shaped open cells A is formed by the twisted pairs **408** and the crossing strands **410**. Each cell A has two sides near the apex **404** that are formed from adjacent twisted pairs **408**, and two sides farther from the apex **404** that are formed from crossing strands **410** that diverge from those two twisted pairs. For example, one of cells A is formed from twisted pairs **408a** and **408b**, and strand **410a'** that crosses under strand **410b''**.

The strands **410** continue in substantially straight paths from nodes I to the open end **404** where pairs of strands are coupled together at nodes II, thereby defining a second ring of six diamond-shaped, open cells B. The distance  $L_2$  between the points of divergence of the strands **310** forming the twisted pairs **308** and the nodes II is preferably approximately 1.1 inch. Each of cells B is defined on two sides nearest the apex **404** by the two strands **410** that diverge from one of the twisted pairs **408** and the two strands from adjacent twisted pairs that cross the first two strands. For example, one of cells B is formed on two sides from strands **410a'** and **410a''** that diverge from twisted pair **408a**, and on two other sides from strands **410c'''** and **410b'** that cross strands **410a'** and **410a''** respectively.

The strands **410** diverge from nodes II and are each joined, at nodes III, with a strand diverging from an adjacent node II, thereby forming a third ring of cells C adjacent the open end **406** of the filter portion **400**. For example, one of cells C is formed from strands **410a'** and **410b''** that cross at a node I, are joined to strands **410c''** and **410f'** respectively at adjacent nodes II, and each diverge therefrom and are joined at a node III. Each of cells C includes only one crossing region, node I, at which the strands are slidably movable relative to each other.

The anchoring portion is formed from a fourth ring of six diamond-shaped cells D, each cell D sharing a side with each of two neighboring cells C. The same strands that diverge from a node II at one corner of each cell D again join at a node IV at an opposite corner of the cell. Adjacent nodes III form the other two corners of each cell D. For example, nodes II', III', IV' and III'' form the corners of cell D', and nodes II'', III'', IV'' and III''' form the corners of an adjacent cell D''. Filter portion **400** has one fewer ring of cells than filter **300**. Cells A and C are each formed from strands forming only one crossing region I where the strands are slidably movable relative to each other. The strands or twisted pairs forming each of cells A and C are joined together at their other corners. There is only one intermediate ring of cells B, and these cells each have only two nodes I where the strands are slidably movable relative to each other.

The strands **410** diverging from the twisted pairs **408** in filter **400**, like the strands **310** in filter **300**, do not exhibit any sharp bends that would interfere with their ability to slide relative to each other. This feature permits a smooth transition from the compressed state to the expanded condition.

Referring now to FIGS. **11** and **11A**, another embodiment of a filter intended for use in an especially large vena cava has an expanded diameter of about 40–43 mm. This embodiment is similar in most respects to the embodiment illustrated in FIGS. **10** and **10A**, however, it has an extra pair of strands **510**. Each coaxial ring of cells in the filter portion **500** has three coaxial rings of cells A, B, and C, and the

14

anchor portion **502** has one ring D. Each ring includes seven cells instead of the six cells in each ring in the embodiment illustrated in FIGS. **10** and **10A**.

Cells A and C each include one crossing region I of strands that are slidably movable relative to each other, and cells B each include two such crossing regions I. The strands defining cells D of the anchor portion **502**, however, are joined together at their crossing regions. For example, nodes II', III', IV' and III'' form the corners of cell D', and nodes II'', III'', IV'' and III''' form the corners of an adjacent cell D''. In each of the embodiments illustrated in FIGS. **10** and **11**, the strands **410**, **510** are joined at nodes III and IV by positioning a small cylindrical sleeve **412**, **512** around a pair of strands and then by welding or crimping the sleeve **412**, **512** to the strands.

Hooks **413**, **513** are coupled to the anchoring portions **402**, **502** at nodes III for engaging the inner wall of a blood vessel such that the filter will not slip out of position once emplaced.

FIGS. **12A** and **12B** depict yet a further embodiment of the present invention. In such an embodiment, blood clot filter **600** includes anchoring portion **612** and filtering portion **614** as in the earlier disclosed embodiments. In particular, blood clot filter **600** is constructed of similar materials and in a similar manner as disclosed with respect to filters **10**, **150**, **170** and **192** depicted in FIGS. **1**, **6**, **7** and **8**, respectively. Moreover, anchoring portion **612** is constructed of similar materials and in a similar manner as disclosed with respect to anchoring portions **12**, **152**, **172**, **190**, **302** and **402**, and filtering portion **614** is constructed of similar materials and in a similar manner as disclosed with respect to filtering portions **14**, **154**, **174**, **194**, **300** and **400**, as depicted in FIGS. **1**, **6**, **7**, **8**, **9** and **10**, respectively.

More particularly, anchoring portion **612** includes a plurality of closed cells **620** which are arranged circumferentially to form a ring **618**. As ring **618** defines the length of anchoring portion **612** and therefore the entire length of blood clot filter **600**, the present invention contemplates including a plurality of rings **618** arranged in an end-to-end fashion to define any particular desired length. Anchoring portion **612** further includes open distal end **624** and open proximal end **626** as well as lumen **625** extending there-through.

As depicted in FIGS. **12A** and **12B**, blood clot filter **600** further includes filtering portion **614** which is concentrically aligned within lumen **625** of anchoring portion **612**. Filtering portion **614** includes open proximal end **634** and tapers to form apex **604** at distal end tip **636**, thus forming a conical body for filtering portion **614**. Proximal end **634** of filtering portion **614** is adjacent distal end **624** of anchoring portion **612**, with the conical body of filtering portion **614** extending concentrically within the interior inner lumen **625** of anchoring portion **612**. In this manner, filtering portion **614** of blood clot filter **600** is properly centered within lumen **625**, thereby symmetrically centering apex **604** within the lumen of the blood vessel, being uniformly spaced from anchoring portion **612** and from the wall of the blood vessel.

Filtering portion **614** may be formed in any arrangement, such as described herein with respect to the embodiments depicted in FIGS. **1–10**. For example, filtering portion **614** may include a plurality of cells circumferentially aligned and coupled as described with respect to FIGS. **1–2**, or may include helical or spiral legs or strands as described with respect to FIGS. **6–10**. As such, filtering portion **614** can be constructed as described with respect to such embodiments herein.

Anchoring portion 612 and filtering portion 614 may be provided as contiguous members, as depicted in FIG. 12A. In such an embodiment, blood clot filter 600 is formed from a single piece of material, with distal end 624 of anchoring portion 612 and proximal end 634 of filtering portion 614 being contiguous with respect to each other. Preferably, this is accomplished by providing the elongated strands 638 which form the cells 620 of anchoring portion 612 as a continuous portion which inverts at distal end 624 to form filtering portion 614. This is most preferably accomplished by helically twisting together respective portions of the elongated strands defining neighboring cells of anchoring portion 612 which form ring 618 adjacent distal end 624 of anchoring portion 612, and then bending the elongated strands into lumen 625 of anchoring portion 614 to form filtering portion 614. The helical twisting at the coupling between cells is further described herein with respect to the embodiments shown in FIGS. 1B and 2B. Such helical twisting further permits some rotation about the joints, thereby permitting sufficient movement of the strands and providing a hinging effect. As such, bending of the strands into lumen 625 to form filtering portion 614 may be accomplished due to flexing and hinging at the helically twisted coupling.

Alternatively, portion 612 and filtering portion 614 may be provided as separate, discrete members, as depicted in FIG. 12B. In this manner, anchoring portion 612 and filtering portion 614 may be independently fabricated and then attached to each other to form blood clot filter 600. In this embodiment, anchoring portion 612 and filtering portion 614 are discrete portions which are fixedly attached at distal end 624 of anchoring portion 612 and proximal end 634 of filtering portion 614, for example through attachment means 650.

Attachment means 650 may be any known attachment means. Preferably, attachment means 650 is a suture or knot which is capable of tying between distal end 624 of anchoring portion 612 and proximal end 634 of filtering portion 614. Attachment means 650 may be provided in either a tight engagement or a loose engagement. Preferably, attachment means 650 is provided in a loose engagement, so as to permit movement at the juncture between distal end 624 of anchoring portion 612 and proximal end 634 of filtering portion 614, thereby providing a hinge-like engagement.

By providing blood clot filter 600 with filtering portion 614 concentrically aligned within the lumen of anchoring portion 612, filtering portion 614 may be turned inside out, thereby extending filtering portion 614 outside of lumen 625 of anchoring portion 612. In this manner, blood clot filter 600 can be retrieved from an implant site and explanted from the blood vessel. This may be accomplished from the hinging effect provided through the helical twisting of the strands, and by the hinge-like engagement provided by anchoring portions 650 between distal end 624 of anchoring portion 612 and proximal end 634 of filtering portion 614.

As indicated, anchoring portion 612 is formed of closed cells 620 circumferentially arranged to form rings 618. Such an arrangement provides anchoring portion 612 with a symmetrical, uniform diameter. As noted, filtering portion 614 is positioned within lumen 625 of anchoring portion 612 and is tapered in the form of a conical body, with apex 604 formed at distal end 636 thereof. By providing the conical body of filtering portion 614 within lumen 625 in this manner, uniform spacing of filtering portion 614 and apex 604 within anchoring portion 612 is effectively achieved due in part to the uniform diameter of anchoring portion 612. Thus, filtering portion 614 is provided with a self-centering

characteristic, and blood clot filter 600 can be effectively centered within the lumen of the blood vessel.

Moreover, the symmetrical, uniform diameter of anchoring portion 612 provides a uniform radial expansion force of blood clot filter 600 within a blood vessel. Such uniform radial expansion force promotes a desired tissue response and further ensures reliable anchoring of blood clot filter 600 centrally within the vessel.

Although the invention has been described in connection with blood clot filtering in the vena cava, the present invention would also be useful for filtering clots in other areas of the vascular anatomy. For example, blood clot filtering may be useful in vessels leading to the brain. The filter used in such applications would be constructed of appropriate size and of appropriate material to provide proper anchoring force against an inner wall surface of the vessel in which the filter is disposed.

In further embodiments, the respective strands 38 and hooks 44 in regions of contact 40 (FIG. 1) in the anchoring portion of the filter may be joined together using laser welding along a length of about, e.g., 2-3 mm, instead of using a hypotube and resistance welding.

In other embodiments, the filter may be of the non-self-expanding type, preferably delivered using a catheter having an expandable balloon. The cells can be made of plastically deformable material, which may be, for example, tantalum, titanium, or stainless steel.

In still other embodiments, the filter may be formed of a temperature-sensitive shape memory material with a transition temperature around body temperature. The filter may then be delivered in a compressed condition in one crystalline state and expanded by crystalline phase transformation when exposed to body temperature.

In other embodiments, at least a portion of the filter may be formed from nitinol wire having a core of tantalum wire or other radiopaque material, as described in U.S. Ser. No. 07/861,253, filed Mar. 31, 1992 and U.S. Ser. No. 07/910,631, filed Jul. 8, 1992, both of which are herein incorporated by reference. This enhances the radiopacity of the filter so that the filter may be viewed using X-ray fluoroscopy to monitor placement and operation of the filter.

In still other embodiments, the filter may be coated with a drug for in vivo compatibility prior to delivery into the body. For example, the filter may be coated with heparin, as described in U.S. Pat. Nos. 5,135,516 and 5,304,121, which are herein incorporated by reference.

Other embodiments are within the scope of the claims.

What is claimed is:

1. A blood clot filter comprising:

- a anchoring portion comprising a radially expandable body which in the uncompressed state is generally cylindrical having first and second ends and including an axial lumen extending therethrough, said anchoring portion including a plurality of closed cells forming a series of circumferential rings; and
  - a filtering portion comprising a generally conical body concentrically aligned with said axial lumen of said anchoring portion, said conical body including an open end adjacent said anchoring portion, said conical body tapering to form a tip.
2. A blood clot filter as in claim 1, wherein said anchoring portion is radially compressible and self-expandable.
3. A blood clot filter as in claim 1 said closed cells connecting said anchoring portion and said filtering portion.
4. A blood clot filter as in claim 1, wherein said filter is formed from a single piece of material and said anchoring portion is contiguous with said filtering portion.

17

5. A blood clot filter as in claim 1, wherein said plurality of circumferential cells includes adjacent cells fixedly joined together at respective regions of contact.

6. A blood clot filter as in claim 1, wherein said filtering portion includes a plurality of circumferential cells.

7. A blood clot filter as in claim 6, wherein said plurality of cells form a series of circumferential rings, said series of circumferential rings decreasing in circumference along the axis of said filtering portion toward said distal tip.

8. A blood clot filter as in claim 1, wherein said plurality of circumferential cells includes adjacent cells fixedly joined together at respective regions of contact.

9. A blood clot filter as in claim 1, wherein said filtering portion is formed from a plurality of elongated strands arranged to form a generally conical structure, said plurality of elongated strands extending from said open distal end of said filtering portion and tapering to form said distal tip of said filtering portion.

10. A blood clot filter as in claim 9, wherein said elongated strands are fixedly attached to one another only at said tip of said filtering portion.

11. A blood clot filter as in claim 10, wherein said elongated strands extend from said open distal end of said filtering portion in a spiral to said distal tip to form said filtering portion.

12. A blood clot filter as in claim 11, wherein said elongated strands spiral in the same helical direction toward said tip.

13. A blood clot filter as in claim 11, wherein said elongated strands spiral in opposing helical directions toward said tip.

14. A blood clot filter as in claim 13, wherein said elongated strands spiral in opposing helical directions to form a plurality of cells defining said filtering portion.

15. A blood clot filter as in claim 14, wherein said elongated strands forming said plurality of cells are slidably movable with respect to each other.

16. A blood clot filter as in claim 1, wherein said anchoring portion and said filtering portion are formed from material selected from the group consisting of polymeric material, metallic material and shape-memory material.

17. A blood clot filter as in claim 16, wherein said shape-memory material is nitinol.

18. A blood clot filter as in claim 1, wherein said anchoring portion includes hooks for attaching said filter to an interior of a luminal surface.

19. A blood clot filter comprising:

an anchoring portion, comprising a radially expandable body, said radially expandable body including an axial lumen extending therethrough and which in the uncompressed state is generally cylindrical, said anchoring portion including axially aligned elongate strands which cooperate to urge the anchoring portion into a generally cylindrical expanded configuration; and

a filtering portion comprising a generally conical body concentrically aligned with said axial lumen of said anchoring portion and tapering from said anchoring portion,

wherein said anchoring portion and said filtering portion are substantially non-overlapping.

20. A blood clot filter as in claim 19, wherein said elongate strands extend into said filter portion to form said conical body.

21. A blood clot filter as in claim 19, wherein said elongate strands extend to form a plurality of closed cells which transition from said cylindrical anchoring portion to said conical filtering portion and wherein said elongate strands cooperate to prevent distortion of said cylindrical configuration.

18

22. A blood clot filter as in claim 19, wherein said anchoring portion and said filtering portion are formed from a single piece of material.

23. A blood clot filter as in claim 19, wherein said anchoring portion includes hooks extending therefrom.

24. A blood clot filter of claim 19, wherein said anchoring portion includes closed cells.

25. A blood clot filter of claim 19, wherein said filtering portion includes closed cells.

26. A blood clot filter of claim 25, wherein said closed cells in said filtering portion are diamond shaped.

27. A blood clot filter of claim 19, wherein said filter is formed of nitinol.

28. A blood clot filter comprising:  
an anchoring portion, comprising a radially expandable body including axial lumen extending therethrough and which in the uncompressed state is generally cylindrical; and

a filtering portion comprising a generally conical body concentrically aligned with said axial lumen of said anchoring portion and tapering from said anchoring portion;

wherein the transition between said anchoring portion to said filtering portion is formed by closed cells.

29. A blood clot filter as in claim 28, wherein a portion of said closed cells extends between said anchoring portion and said filtering portion.

30. A blood clot filter of claim 28, wherein said tapering of said conical body is external to said cylindrical portion.

31. A blood clot filter of claim 28, wherein said tapering section of said conical section is internal to said cylindrical portion.

32. A blood clot filter of claim 28, wherein said anchoring portion includes hooks extending therefrom.

33. A blood clot filter of claim 28, wherein said filtering portion includes closed cells.

34. A blood clot filter of claim 28, wherein said filter is formed of nitinol.

35. A blood clot filter of claim 28, wherein said filter is formed from a single piece of material.

36. A blood clot filter comprising:  
an anchoring portion, comprising a radially expandable body which is generally cylindrical in the uncompressed state and having an axial lumen extending therethrough, said anchoring portion including axially aligned elongate strands which define wall portions of closed cells and which cooperate to form said cylindrical shape of said anchoring portion; and

a filtering portion, comprising a generally conical body concentrically aligned with and tapering from said anchoring portion.

37. A blood clot filter as in claim 36, wherein said anchoring portion further includes closed cells formed by elongate strands.

38. A blood clot filter of claim 36, wherein the transition between said anchoring portion and said filtering portion is formed by said closed cells.

39. A blood clot filter of claim 36, wherein said anchoring portion includes hooks extending therefrom.

40. A blood clot filter of claim 36, wherein said filter is formed from a single piece of material.

41. A blood clot filter of claim 36, wherein said filtering portion includes closed cells.

42. A blood clot filter of claim 36, wherein said filter is formed of nitinol.

43. A blood clot filter of claim 36, wherein said filtering portion includes closed cells which are diamond shaped.

UNITED STATES PATENT AND TRADEMARK OFFICE  
**CERTIFICATE OF CORRECTION**

PATENT NO. : 6,214,025 B1  
DATED : April 10, 2001  
INVENTOR(S) : Thistle et al.

Page 1 of 1

It is certified that error appears in the above-identified patent and that said Letters Patent is hereby corrected as shown below:

Title page.

The Attorney, Agent or Firm incorrectly reads "Hoffman & Baron LLP"; the patent should read -- Hoffmann & Baron, LLP --.

Column 17.

Line 9, the printed patent incorrectly reads "toward said distal tip"; and as amended at page 3 of the Reponse to Office Action dated September 8, 2000, should read -- toward said tip --.

Line 15, the printed patent incorrectly reads "from said open distal end of": and as amended at page 3 of the Response to Office Action dated September 8, 2000, should read -- from said open end of --.

Line 16, the printed patent incorrectly reads "from said distal tip of"; and as amended at page 3 of the Response to Office Action dated September 8, 2000, should read -- from said tip of --.

Line 22, the printed patent incorrectly reads "said open distal end of said" and as amended at page 4 of the Response to Office Action dated September 8, 2000, should read -- said open end of said --;

Line 23, the printed patent incorrectly reads "spiral to said distal tip"; and as amended at page 4 of the Response to Office Action dated September 8, 2000, should read -- spiral to said tip --.

Signed and Sealed this

Nineteenth Day of February, 2002

Attest:



Attesting Officer

JAMES E. ROGAN  
Director of the United States Patent and Trademark Office