

UNITED STATES PATENT AND TRADEMARK OFFICE

---

BEFORE THE PATENT TRIAL AND APPEAL BOARD

---

ZIMMER HOLDINGS, INC.  
and ZIMMER, INC.,  
Petitioner,

v.

BONUTTI SKELETAL INNOVATIONS LLC,  
Patent Owner.

---

Case IPR2014-00191  
Patent 7,837,736 B2

---

Before WILLIAM V. SAINDON, MICHAEL R. ZECHER, and  
RICHARD E. RICE, *Administrative Patent Judges*.

RICE, *Administrative Patent Judge*.

DECISION  
Institution of *Inter Partes* Review  
37 C.F.R. § 42.108

## I. INTRODUCTION

Zimmer Holdings, Inc. and Zimmer, Inc. (“Petitioner”) filed a corrected Petition (Paper 8, “Pet.”) requesting an *inter partes* review of claims 15-28 and 31-36 of U.S. Patent No. 7,837,736 B2 (Ex. 1001, “the ’736 Patent”). The owner of the ’736 Patent, Bonutti Skeletal Innovations LLC (“Patent Owner”), did not file a preliminary response. We have jurisdiction under 35 U.S.C. § 314.

The standard for instituting an *inter partes* review is set forth in 35 U.S.C. § 314(a), which provides as follows:

**THRESHOLD** -- The Director may not authorize an *inter partes* review to be instituted unless the Director determines that the information presented in the petition filed under section 311 and any response filed under section 313 shows that there is a reasonable likelihood that the petitioner would prevail with respect to at least 1 of the claims challenged in the petition.

Based upon this standard, we determine that the information presented in the Petition establishes that there is a reasonable likelihood that Petitioner would prevail with respect to claims 15-22, 26-28, and 31-36, but not claims 23-25 of the ’736 Patent. Accordingly, pursuant to 35 U.S.C. § 314, we authorize an *inter partes* review to be instituted only as to claims 15-22, 26-28, and 31-36.

### A. *Related Proceeding*

Petitioner represents that the ’736 Patent is asserted by Patent Owner against Petitioner in litigation titled *Bonutti Skeletal Innovations, LLC v. Zimmer Holdings, Inc.*, No. 1:12-cv-01107-GMS (D. Del). Pet. 1; *see* Paper 5, 2.

*B. The '736 Patent (Ex. 1001)*

The '736 Patent, titled "MINIMALLY INVASIVE SURGICAL SYSTEMS AND METHODS," issued on November 23, 2010, based on U.S. Patent Application No. 11/928,898, filed on October 30, 2007. The '736 Patent claims priority to U.S. Patent Application No. 10/681,526, filed on October 8, 2003, which is a continuation of U.S. Patent Application No. 10/191,751, filed on July 8, 2002. The '736 Patent also claims priority to a number of earlier-filed U.S. patent applications.

Figure 90 of the '736 Patent, which is reproduced below, depicts rotating platform knee implant 1290.

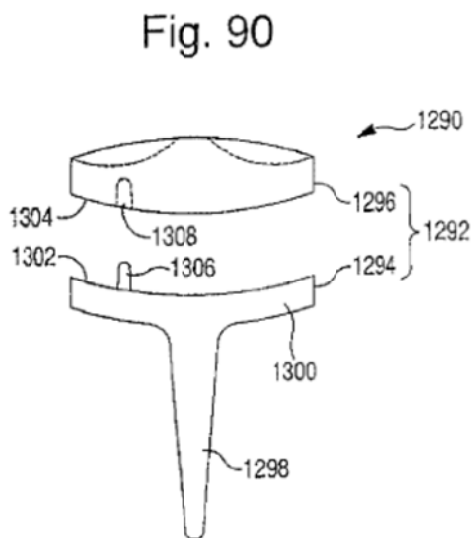

Figure 90 is a schematic illustration of tibial component 1292 of rotating platform knee implant 1290.

As depicted in Figure 90, tibial component 1292 includes tray 1294 and bearing insert 1296. Ex. 1001, 101:14-15. Tray 1294 includes tapered spike 1298 and plate member 1300. *Id.* at 101:15-16. The specification discloses that plate

member 1300 has a concave, spherically-shaped plateau surface (superior surface 1302). *Id.* at 101:18-20. Superior surface 1302 is provided with post 1306. *Id.* at 101:28-29. As described in the specification, post 1306 cooperates with recess 1308 located on bearing insert 1296 to permit rotation of bearing insert 1296 with respect to tibial tray 1294. *Id.* at 101:28-31.

Post 1306 is offset medially toward the medial compartment of the knee. *Id.* at 101:56-57; fig. 90. “In prior art rotating platform designs,” according to the specification, “the post is substantially in line with the central keel.” *Id.* at 101:58-59. The ’736 Patent discloses that “[o]ffsetting post 1306 more toward the medial compartment of the knee recreates the natural pivoting motion o[f] the knee, with less translation medially, a more stable joint medially, and more rotational arc or more movement laterally.” *Id.* at 101:63-67.

### *C. Illustrative Claims*

Claims 15 and 31 are independent. Claims 16-28 depend directly or indirectly from claim 15, and claims 32-36 depend directly from claim 31. Claims 15 and 23 are reproduced below:

15. A device to replace an articulating surface of a first side of a joint in a body, the joint having first and second sides, comprising:

a base component, including a bone contacting side connectable with bone on the first side of the joint, and a base sliding side on an opposite side of said base component relative to said bone contacting side;

a movable component, including a movable sliding side, said movable sliding side being matably positionable in sliding engagement with said base sliding side, and an articulating side on an opposite side of said

movable component relative to said movable sliding side, shaped to matingly engage an articulating surface of the second side of the joint;

a protrusion extending from one of said base sliding side or movable sliding side, said protrusion substantially offset with respect to a midline of the first side of a joint;

a recess sized to receive said protrusion, disposed in the other of said base sliding side or movable sliding side, said protrusion and recess matable to constrain movement of said first and second components relative to each other, thereby promoting movement of the joint within desired anatomical limits.

23. The device of claim 15, wherein said protrusion is a dovetail pin and said recess is a dovetail tail, together forming a dovetail joint.

*D. The Asserted Prior Art*

Petitioner contends that the “priority date” (earliest effective filing date) for the challenged claims of the ’736 Patent is July 8, 2002. Pet. 14. Petitioner relies upon the following prior art references (*id.* at 4):

Walker	US 5,755,801	May 26, 1998 (filed July 18, 1994)	Ex. 1002
Insall ’283	US 6,319,283 B1	Nov. 20, 2001 (filed July 2, 1999)	Ex. 1003
Insall ’658	US 6,068,658	May 30, 2000 (filed Mar. 9, 1998)	Ex. 1004

Petitioner asserts that Walker is prior art to the challenged claims under 35 U.S.C. § 102(b), and Insall '283 and Insall '658 are prior art to the challenged claims under 35 U.S.C. § 102(a) and (e). *Id.* at 15, 18, and 20-21.

*E. The Asserted Grounds*

Petitioner challenges claims 15-28 and 31-36 of the '736 Patent on the following grounds (*id.* at 4-5):

Reference(s)	Basis	Claims Challenged
Walker	§ 102(b)	15-22, 25-28, and 31-36
Walker and Insall '283	§ 103	15-22, 25-28, and 31-36
Walker and Insall '658	§ 103	15-28 and 31-36
Walker, Insall '658, and Insall '283	§ 103	15-28 and 31-36
Insall '658	§ 102(a), (e) <sup>1</sup>	15, 16, 18-28, 31, and 34-36
Insall '283	§ 102(a), (e)	15, 16, 18-22, 25-28, 31, and 34-36

---

<sup>1</sup> Petitioner states on page 5 of the Petition that the statutory basis for the fourth-listed ground is 35 U.S.C. § 102(b). This statement is inconsistent with the statement on pages 20-21 of the Petition that Insall '658 is prior art to the challenged claims under 35 U.S.C. § 102(a) and (e). Accordingly, we treat the fourth-listed ground as asserted under 35 U.S.C. § 102(a) and (e), not 35 U.S.C. § 102(b).

## II. ANALYSIS

### A. Claim Construction

Consistent with the statute and legislative history of the Leahy-Smith America Invents Act, Pub. L. No. 112-29, 125 Stat. 284 (2011) (“AIA”), we interpret claims using the “broadest reasonable construction in light of the specification of the patent in which [they] appear[.]” 37 C.F.R. § 42.100(b); *see* Office Patent Trial Practice Guide, 77 Fed. Reg. 48,756, 48,766 (Aug. 14, 2012). There is a “heavy presumption” that a claim term carries its ordinary and customary meaning. *CCS Fitness, Inc. v. Brunswick Corp.*, 288 F.3d 1359, 1366 (Fed. Cir. 2002). However, a “claim term will not receive its ordinary meaning if the patentee acted as his own lexicographer and clearly set forth a definition of the disputed claim term in either the specification or prosecution history.” *Id.* “Although an inventor is indeed free to define the specific terms used to describe his or her invention, this must be done with reasonable clarity, deliberateness, and precision.” *In re Paulsen*, 30 F.3d 1475, 1480 (Fed. Cir. 1994). Also, we must be careful not to read a particular embodiment appearing in the written description into the claim if the claim language is broader than the embodiment. *See In re Van Geuns*, 988 F.2d 1181, 1184 (Fed. Cir. 1993) (“[L]imitations are not to be read into the claims from the specification.”). The broadest reasonable construction of a means-plus-function limitation “is that statutorily mandated in [paragraph f<sup>2</sup> of 35 U.S.C. § 112].” *In re Donaldson Co.*, 16 F.3d 1189, 1194-95 (Fed. Cir. 1994).

---

<sup>2</sup> We note that the provisions of former 35 U.S.C. § 112 ¶ 6 have been re-codified, without change, as 35 U.S.C. § 112 ¶ f.

Here, challenged claim 25 recites “*means* associated with said protrusion to prevent a separation of said base sliding side and said movable sliding side.” Ex. 1001, 114:61-63 (emphasis added). The use of “means” creates the presumption that claim 25 recites a means-plus-function limitation. *See Personalized Media Commc’ns, LLC v. Int’l Trade Comm’n*, 161 F.3d 696, 703 (Fed. Cir. 1998); *Rodime PLC v. Seagate Tech., Inc.*, 174 F.3d 1294, 1302 (Fed. Cir. 1999) (“Because the element uses the word “means,” this court presumes that § 112 ¶ 6 applies. This court next looks to whether the element specifies a function for performing the claimed means.”). Claim 25 clearly recites a function for performing the claimed “means,” i.e., “to prevent a separation of said base sliding side and said movable sliding side.” “[E]ven if the claim element specifies a function, [however,] if it also recites sufficient structure or material for performing that function, § 112 ¶ 6 does not apply.” *Rodime*, 174 F.3d at 1302 (citation omitted). As claim 25 does not recite sufficient structure or material for performing the specified function, the “means” clause is a “means-plus-function” limitation.

Because claim 25 contains a means-plus-function limitation, the Petition is required to state how the means-plus-function limitation in claim 25 should be construed, and should have identified “the specific portions of the specification that describe the structure, material, or acts corresponding to each claimed function.” *See* 37 C.F.R. § 42.104(b)(3). The Petition does not provide this required claim construction analysis for claim 25. We will not go through the specification of the ’736 Patent and determine the corresponding structure and equivalents thereto for the means-plus-function limitation recited in claim 25—this



is something that Petitioner should have done in its Petition. In view of Petitioner's failure to comply with 37 C.F.R. § 42.104(b)(3), we do not construe the means-plus-function limitation in claim 25.

*B. Alleged Grounds of Unpatentability*

We turn now to Petitioner's asserted grounds of unpatentability to determine whether Petitioner has met the threshold standard of 35 U.S.C. § 314(a). Below, we separately analyze: (1) claims 15-22, 26-28, and 31-36; (2) claim 25; and (3) claims 23 and 24.

*1. Claims 15-22, 26-28, and 31-36 as Anticipated by Walker*

Based on the current record, we are persuaded that Walker anticipates claims 15-22, 26-28, and 31-36 of the '736 Patent. *See* Pet. 28-36.

*a. Walker (Ex. 1002)*

Walker relates to prostheses for knee replacement, and discloses an embodiment comprising: a femoral component having at least one condylar bearing surface; a tibial component having tibial platform 41; meniscal component 44 located between the condylar bearing surface and the tibial platform; and stud 42 upstanding from the platform and received in slot 43 in the meniscal component. Ex. 1002, 1:56-65, 4:7-14. "Rotation of the meniscal component 44 about an axis X at the edge of the tibial platform is controlled by a semi-circular abutment 50 which is upstanding at the medial side of the platform." *Id.* at 4:22-25, figs. 2, 2a, & 2b. "A recess or notch 51 is formed in the corresponding portion

of the meniscal component and is rounded as shown to allow approximately 2 mms movement in an anterior and posterior direction.” *Id.* at 4:25-28, figs. 2, 2a, & 2b.

Petitioner’s declarant, Arthur G. Erdman, Ph.D., provides an annotated version of Figure 2 of Walker, reproduced below.

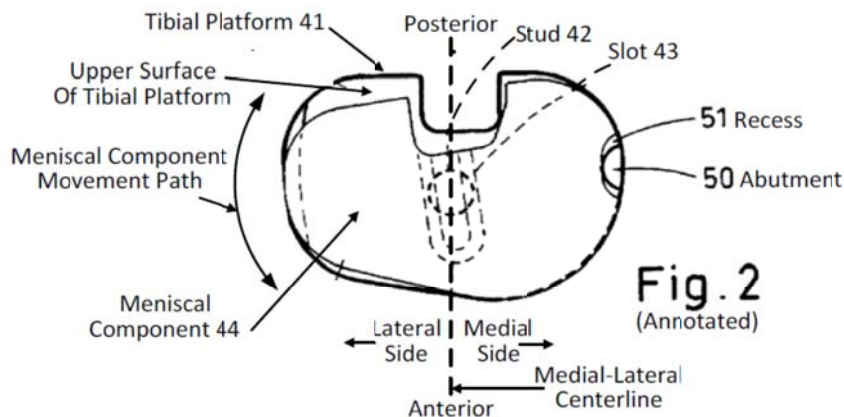

Petitioner’s annotated version of Figure 2 of Walker

Ex. 1005 (Erdman declaration) ¶ 45; *see* Pet 17.

Dr. Erdman testifies that the embodiment depicted in Figure 2 of Walker “has a meniscal component 44 that rotates about an abutment 50 (i.e., a projection or post) on the medial side of the tibial platform 41.” Ex. 1005 ¶ 45. As shown in Figure 2, “[t]he meniscal component 44 is fitted to the tibial platform 41 by engaging the abutment 50 in a recess or notch 51 in the medial side of the meniscal component.” Ex. 1005 ¶ 45.

*b. Analysis*

Claim 15 is directed to a joint replacement device including a base component having a protrusion (or a recess), and a movable component having a recess (or a protrusion). Ex. 1001, 114:5-27. Claim 15 recites “said protrusion

substantially offset with respect to a midline of the first side of a joint,” and “said protrusion and recess matable to constrain movement of said first and second components relative to each other, thereby promoting movement of the joint within desired anatomical limits.” *Id.* at 114:20-21, 24-27.

Claim 16 specifies that the protrusion and recess are substantially offset from a center of the device. *Id.* at 114:28-30. Claims 17 and 18 both specify that the joint is a knee, and claim 17 further specifies that the offset is medial. *Id.* at 114:31-38. Claim 19 requires a second base component connectable to the second side of the joint. *Id.* at 114:39-42. Claim 20, which depends from claim 19, additionally specifies the components are connectable, respectively, to the tibia and the femur. *Id.* at 114:43-47. Claim 21 specifies that the rotation is about an axis of the protrusion. *Id.* at 114:48-51. Claim 22 recites “said protrusion is a pin, and said recess is a hole sized to receive said pin. *Id.* at 114:52-53. Claim 26 recites that “not all articulating compartments of the joint are replaced by said device.” *Id.* at 114:64-65. Claim 27 specifies a location in the body where the joint is located, e.g., a finger. *Id.* at 114:66-67. Claim 28 recites “said protrusion is offset with respect to an axis passing through the anterior-posterior or the medial-lateral center of said base component or movable component.”

Claim 31 is directed to a knee arthroplasty device including a tibial tray having a post (or a cavity), and a tibial tray insert having a cavity (or a post). *Id.* at 115:35-55. Claim 31 recites “said post or cavity offset from at least one of a medial-lateral centerline and an anterior-posterior centerline of said tibial tray,” and “said tibial tray insert rotationally moves with respect to said tibial tray, about said post . . . such that the rotation of the tibial tray insert is asymmetric with

respect to at least one of the medial-lateral centerline and the anterior-posterior centerline of said tibial tray.” *Id.* at 115:38-40, 50-55.

Claims 32 and 33 specify that the offset is medial with respect to a medial-lateral centerline of the tibial tray and the tibial tray insert, respectively. *Id.* at 115:56-116:4. Claims 34 and 35 both recite “the tibial tray has a keel with a central axis”; claim 34 additionally recites “said post or cavity of said tibial tray is offset from the central axis of said keel, and claim 35 additionally recites “said mating post or mating cavity of said tibial tray insert is offset from the central axis of said keel.” *Id.* at 116:5-12. Claim 36 recites “a proximal surface of said tibial tray insert includes a mound interposing a medial condyle receiver and a lateral condyle receiver.” *Id.* at 13-16.

Petitioner asserts that Walker discloses a mobile bearing prosthesis that includes every limitation of claims 15-22, 26-28 and 31-36. Pet. 28 (citing Ex. 1005 ¶¶ 45-69); *see also id.* at 28-35 (claim chart). Having reviewed Petitioner’s assertions and the cited portions of the record, we are persuaded that Petitioner has demonstrated a reasonable likelihood of prevailing on its contention that Walker anticipates claims 15-22, 26-28 and 31-36 of the ’736 Patent.

## 2. Claim 25

Claim 25 recites “[t]he device of claim 15, further including means associated with said protrusion to prevent a separation of said base sliding side and said movable sliding side.” Ex. 1001, 114:61-63. Petitioner alleges claim 25 is anticipated by each of Walker, Insall ’283, and Insall ’658, and as obvious over the combination of Walker and either or both of Insall ’283 and Insall ’658. *See* Pet.

4-5. As discussed above, however, Petitioner has failed to provide the claim construction analysis required by 37 C.F.R. § 42.104(b)(3) for the means-plus-function limitation recited in claim 25. For this reason alone, we are not persuaded Petitioner has demonstrated a reasonable likelihood of prevailing on its contention that claim 25 of the '736 Patent is unpatentable as alleged.

### 3. *Claims 23 and 24*

Claim 23 recites “[t]he device of claim 15, wherein said protrusion is a dovetail pin and said recess is a dovetail tail, together forming a dovetail joint.” Claim 24 depends from claim 23, and recites “said dovetail joint is elongated, extends in a substantially anterior-posterior orientation, and enables anterior-posterior displacement of the base sliding side relative to the movable sliding side.”

Petitioner contends that claims 23 and 24 would have been obvious over (i) Walker and Insall '658 or (ii) Walker, Insall '658, and Insall '283. Pet. 42-44. Petitioner directs our attention to “the complimentary-shaped and interlocking guide 23 and track (including recess 30 and slot 32) of the Insall '658 patent as elements corresponding to the ‘dovetail’ structures in claims 23 and 24 when those terms in claims 23 and 24 are given their broadest reasonable interpretations.” *Id.* at 27-28; *see also id.* at 42-44.

Insall '658 discloses a mobile bearing prosthesis having meniscal component 7 and tibial platform 20. Ex. 1004, 3:28-39; *see* Ex. 1005 ¶ 91. Dr. Erdman provides an annotated version of Figure 6 of Insall '658, reproduced below.

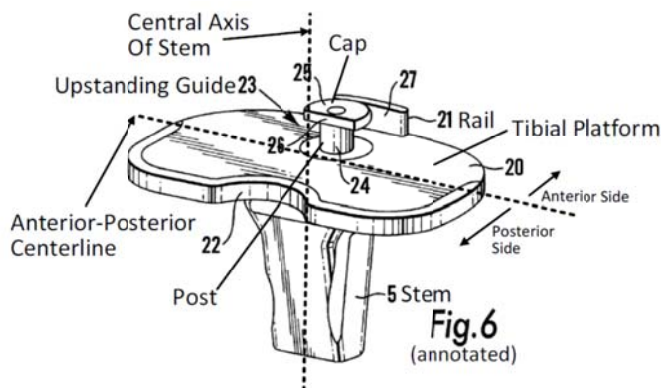

Petitioner's annotated version of Figure 6 of Insall '658

Ex. 1005, ¶ 91; *see* Pet. 22.

As shown in Figure 6, guide 23 comprising cylindrical post 24 and cap 25 stands in an upright position on the tibial platform. *See* Ex. 1005 ¶ 92. The cap is fixed to the top of the post. Ex. 1004, 3:50, fig. 6. Dr. Erdman also provides an annotated version of Figure 5 of Insall '658, reproduced below.

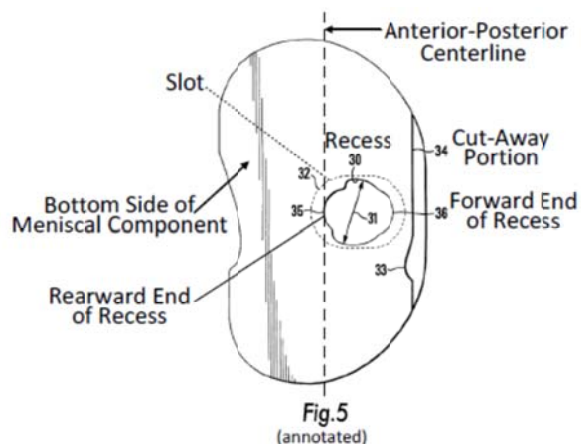

Petitioner's annotated version of Figure 5 of Insall '658

Ex. 1005, ¶ 92; *see* Pet. 22.

As shown in Figure 5, the meniscal component includes recess 30 and slot 32 (together referred to as “the track”). *See* Ex. 1005 ¶ 93 (citing Ex. 1004,

1:42-67); Pet 23. Dr. Erdman testifies “[t]he upstanding guide 23, recess 30, and slot 32 cooperate to retain the meniscal component 7 on the tibial platform 20, *while allowing the meniscal component to both rotate about the guide and move in the anterior-posterior direction.*” Ex. 1005 ¶ 91 (citing Ex. 1004, Abstr., 2:42-46) (emphasis added). We discuss this functionality further below.

Petitioner relies on Dr. Erdman’s declaration in asserting it would have been obvious “to substitute the guide and track of the Insall ’658 patent for the abutment and recess, respectively, in the Walker patent.” Pet. 43 (citing Ex. 1005 ¶¶ 47, 49). In this regard, Dr. Erdman testifies “it would have been a matter of routine engineering and design choice to replace the recess 51 [of Walker] with a hole or slot that extends partially into the meniscal component 44 . . . to permit relative rotational movement of the meniscal component 44 and tibial tray 41.” Ex. 1005 ¶ 47. Dr. Erdman further testifies “evidence that it would have been a matter of routine skill and design choice to substitute a round post and mating hole, respectively, for the abutment 50 and recess 51 to define the rotational axis of the meniscal component is provided by the Insall ’658.” *Id.* ¶ 49. “The Insall ’658 patent also shows a post and hole (i.e., upstanding guide 23, and recess 30 and slot 32) for this purpose.” *Id.*

As for the “dovetail joint” limitation, Petitioner additionally asserts, “[t]he guide 23 and track of the implant shown in the Insall ’658 patent [are] structurally at least equivalent to a dovetail joint, and [are] functionally substantially the same as a dovetail joint.” Pet. 43. Claims 23 and 24, however, explicitly require a “dovetail joint,” not a structure that is “structurally at least equivalent to a dovetail joint” or “functionally substantially the same as a dovetail joint.” *See id.* As

described in Insall '658, the guide comprises a cylindrical post with a cap and the track comprises a recess and a slot. Ex. 1004, 3:44-4:12, figs. 5 & 6. Petitioner has not persuaded us that a person of ordinary skill in the art at the time of the invention would have considered the guide and track of Insall '658 to disclose or suggest the “dovetail joint” recited in claims 23 and 24.<sup>3</sup> Accordingly, we determine that Petitioner has not demonstrated a reasonable likelihood of prevailing on its contention that the subject matter of claims 23 and 24 would have been obvious over (i) Walker and Insall '658 or (ii) Walker, Insall '658, and Insall '283.

#### 4. *Remaining Grounds of Unpatentability*

Petitioner contends that claims 15, 16, 18-28, 31, and 34-36 are unpatentable under 35 U.S.C. § 102(a) and (e) as anticipated by Insall '658; claims 15, 16, 18-22, 26-28, 31, and 34-36 are unpatentable under 35 U.S.C. § 102(a) and (e) as anticipated by Insall '283; and claims 15-22, 26-28, and 31-36 are unpatentable under 35 U.S.C. § 103 as obvious over Walker and either or both of Insall '283 and Insall '658. Those grounds of unpatentability are redundant to the grounds of unpatentability on which we initiate an *inter partes* review. Accordingly, we do not authorize an *inter partes* review on any of those grounds of unpatentability. *See* 37 C.F.R. § 42.108(a).

---

<sup>3</sup> Dr. Erdman's declaration does not discuss claims 23 and 24 or the “dovetail joint” limitation recited in those claims.



### III. CONCLUSION

For the forgoing reasons, we determine that there is a reasonable likelihood that Petitioner would prevail in its challenge of claims 15-22, 26-28, and 31-36 of the '736 Patent as anticipated under 35 U.S.C. § 102(b) by Walker. We, however, have not made a final determination on the patentability of the challenged claims.

### IV. ORDER

Accordingly, it is

ORDERED that pursuant to 35 U.S.C. § 314, an *inter partes* review is hereby instituted as to claims 15-22, 26-28, and 31-36 of the '736 Patent based on anticipation under 35 U.S.C. § 102(b) by Walker;

FURTHER ORDERED that no other grounds of unpatentability are authorized for the *inter partes* review as to claims 15-28 and 31-36 of the '736 Patent; and

FURTHER ORDERED that pursuant to 35 U.S.C. § 314(d) and 37 C.F.R. § 42.4, notice is hereby given of the institution of a trial on the ground of unpatentability authorized above; the trial commences on the entry date of this decision.

Case IPR2014-00191  
Patent 7,837,736 B2

For PETITIONER:

Walter C. Linder  
Daniel Lechleiter  
FAEGRE BAKER DANIELS LLP  
[Walter.Linder@FaegreBD.com](mailto:Walter.Linder@FaegreBD.com)  
[Daniel.Lechleiter@FaegreBD.com](mailto:Daniel.Lechleiter@FaegreBD.com)

For PATENT OWNER :

Cary Kappel  
William Gehris  
DAVIDSON, DAVIDSON & KAPPEL, LLC  
[ckappel@ddkpatent.com](mailto:ckappel@ddkpatent.com)  
[wgehris@ddkpatent.com](mailto:wgehris@ddkpatent.com)