

(12) **United States Patent**
Lyren

(10) **Patent No.:** **US 8,506,642 B1**
(45) **Date of Patent:** **Aug. 13, 2013**

(54) **HIP IMPLANT WITH POROUS BODY**

(76) Inventor: **Philip Scott Lyren**, Cleveland Heights, OH (US)

(*) Notice: Subject to any disclaimer, the term of this patent is extended or adjusted under 35 U.S.C. 154(b) by 1524 days.

(21) Appl. No.: **11/409,611**

(22) Filed: **Apr. 24, 2006**

Related U.S. Application Data

(63) Continuation of application No. 10/446,069, filed on May 27, 2003, now abandoned.

(51) **Int. Cl.**
A61F 2/32 (2006.01)

(52) **U.S. Cl.**
USPC **623/22.11**

(58) **Field of Classification Search**
USPC 623/23.15, 23.26, 23.28–30, 23.34, 623/23.36, 23.44, 23.5–52, 23.55, 23.57, 623/23.6–61, 23.63, 23.75–76
See application file for complete search history.

(56) **References Cited**

U.S. PATENT DOCUMENTS

3,605,123	A *	9/1971	Hahn	623/23.55
3,662,405	A *	5/1972	Bortz et al.	623/23.51
3,707,006	A *	12/1972	Bokros et al.	424/422
3,808,606	A *	5/1974	Tronzo	428/613
3,906,550	A *	9/1975	Rostoker et al.	623/23.55
3,938,198	A *	2/1976	Kahn et al.	623/22.15
4,244,689	A *	1/1981	Ashman	433/175
4,292,695	A *	10/1981	Koeneman	623/23.44
4,314,381	A *	2/1982	Koeneman	623/23.17
4,406,023	A *	9/1983	Harris	623/23.29
4,551,863	A *	11/1985	Murray	623/22.43

4,657,552	A *	4/1987	Karpf	623/23.15
4,713,076	A *	12/1987	Draenert	623/23.6
4,878,919	A *	11/1989	Pavlansky et al.	623/23.18
4,919,670	A *	4/1990	Dale et al.	623/19.14
4,938,409	A *	7/1990	Roberts	228/178
4,976,738	A *	12/1990	Frey et al.	623/23.54
4,997,444	A *	3/1991	Farling	623/23.51
5,002,578	A *	3/1991	Luman	623/22.42
5,002,581	A *	3/1991	Paxson et al.	623/22.44
5,015,256	A *	5/1991	Bruce et al.	128/898
5,024,670	A *	6/1991	Smith et al.	128/898
5,047,054	A *	9/1991	Vijayan et al.	623/23.6
5,108,452	A *	4/1992	DeMane et al.	623/22.42
5,201,766	A *	4/1993	Georgette	128/898
5,219,363	A *	6/1993	Crowninshield et al.	623/23.34
5,236,457	A *	8/1993	Devanathan	128/898
5,282,861	A *	2/1994	Kaplan	
5,286,260	A *	2/1994	Bolesky et al.	623/22.42
5,443,510	A *	8/1995	Shetty et al.	419/2
5,443,512	A *	8/1995	Parr et al.	623/23.51
5,443,515	A *	8/1995	Cohen et al.	623/17.16
5,489,306	A *	2/1996	Gorski	623/23.55
5,504,300	A *	4/1996	Devanathan et al.	219/121.64

(Continued)

OTHER PUBLICATIONS

J.D. Bobyn, "Characteristics of bone ingrowth and interface mechanics of a new porous tantalum biomaterial" The Journal of Bone and Joint Surgery, Sep. 5, 1999.

(Continued)

Primary Examiner — Mary Hoffman

(57) **ABSTRACT**

A hip implant having two distinct bodies, a neck body and a bone fixation body. The neck body is formed from a solid metal and has an interface for connecting to a femoral ball. The bone fixation body has an elongated shape and is formed as a porous structure that is inserted into an intramedullary canal of a patient.

4 Claims, 3 Drawing Sheets

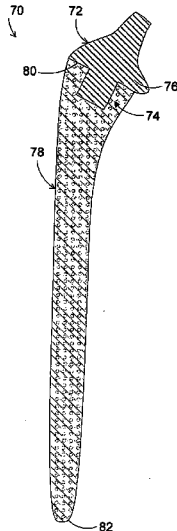

(56)

References Cited

U.S. PATENT DOCUMENTS

5,507,814 A * 4/1996 Gilbert et al. 623/23.52
 5,522,894 A * 6/1996 Draenert 623/23.61
 5,571,185 A * 11/1996 Schug 623/22.11
 5,580,352 A * 12/1996 Sekel 623/22.46
 5,653,764 A * 8/1997 Murphy 623/23.15
 5,658,352 A * 8/1997 Draenert 623/22.4
 5,702,483 A * 12/1997 Kwong 623/22.4
 5,800,560 A * 9/1998 Draenert 623/22.43
 5,876,446 A * 3/1999 Agrawal et al. 623/23.61
 5,993,716 A * 11/1999 Draenert 264/221
 6,066,176 A * 5/2000 Oshida 623/23.62
 6,296,667 B1 * 10/2001 Johnson et al. 623/23.61
 6,464,728 B1 * 10/2002 Murray 623/22.42
 6,497,728 B2 * 12/2002 Yong 623/23.46
 6,746,488 B1 * 6/2004 Bales 623/23.51
 7,135,044 B2 * 11/2006 Bassik et al. 623/22.42
 7,914,584 B2 * 3/2011 Bigsby et al. 623/22.42
 7,981,161 B2 * 7/2011 Choi et al. 623/22.42

8,048,167 B2 * 11/2011 Dietz et al. 623/22.42
 2002/0151984 A1 * 10/2002 White 623/23.22
 2003/0074079 A1 * 4/2003 McTighe et al. 623/22.42
 2004/0243246 A1 * 12/2004 Lyren 623/22.11
 2005/0043811 A1 * 2/2005 Doubler et al. 623/22.42
 2006/0134157 A1 * 6/2006 Lehman et al. 424/422
 2007/0043447 A1 * 2/2007 Cheal et al. 623/22.43

OTHER PUBLICATIONS

J.D. Bobyn, "Characterization of new porous tantalum biomaterial for reconstructive orthopedics" 66th Meeting of the American Academy of Orthopedic Surgeons Feb. 4-8, 1999.
 S.A. Hacking, "Fibrous tissue ingrowth and attachment to porous tantalum" Journal of Biomedical Materials Research, 52, 631-638, 2000.
 Zhang Y, "Interfacial frictional behavior: cancellous bone, cortical bone, and a novel porous tantalum biomaterial" Journal of Musculoskeletal Research, 3(4):245-251 (1999).

* cited by examiner

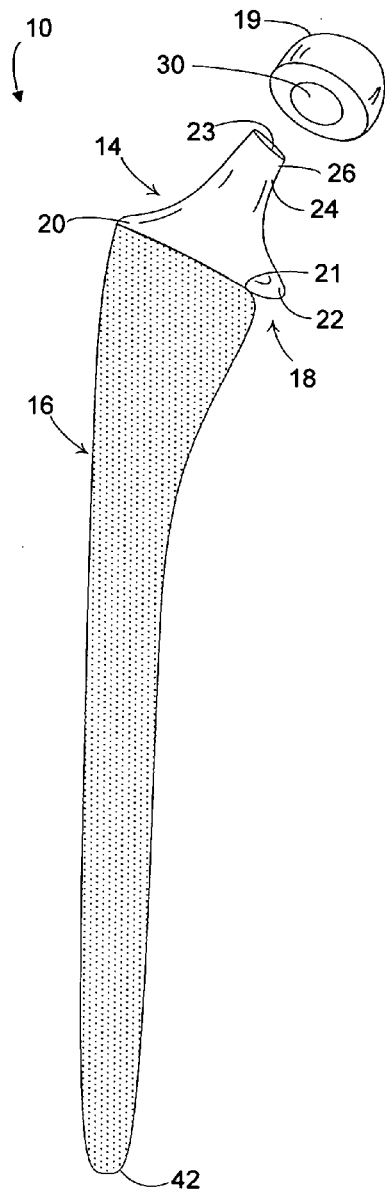

Fig. 1

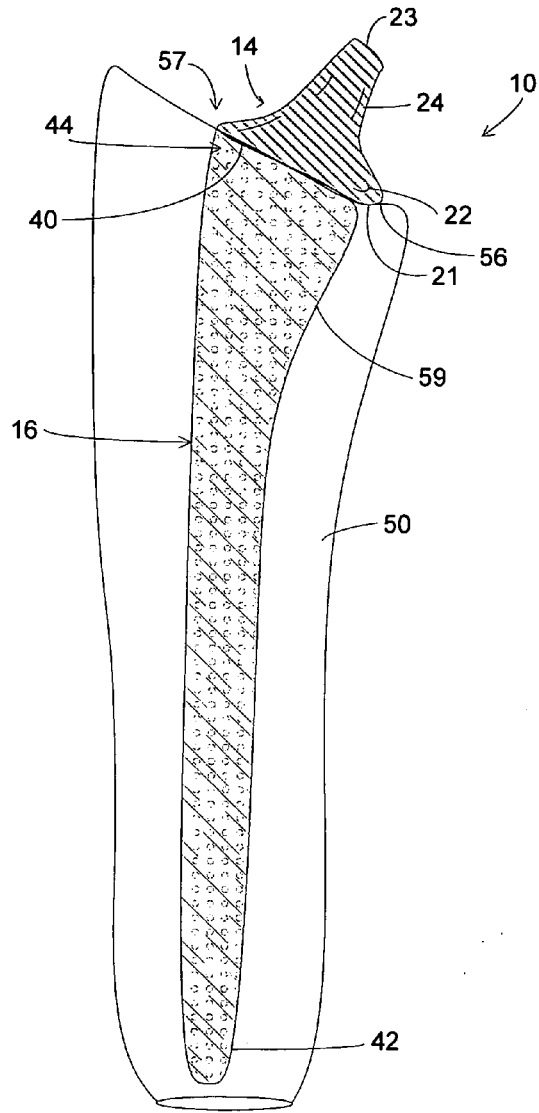

Fig. 2

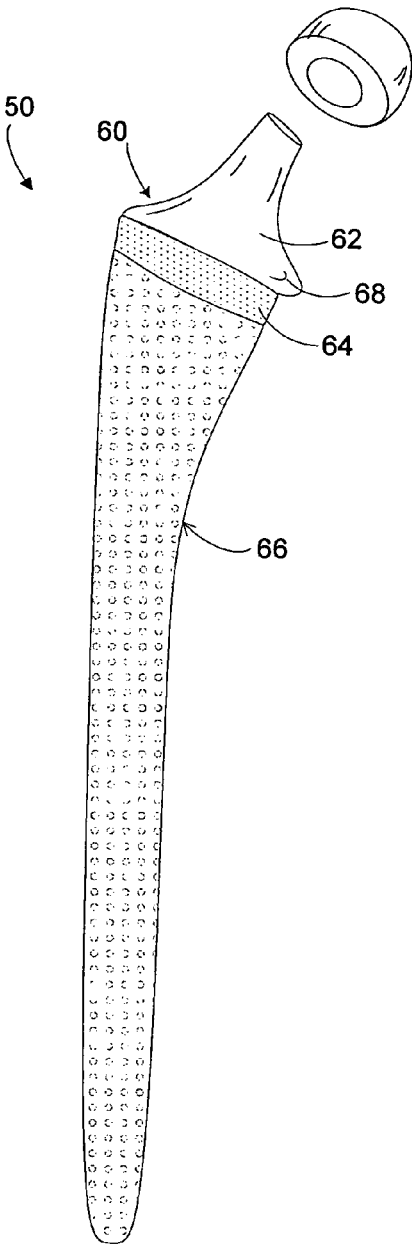

Fig. 3

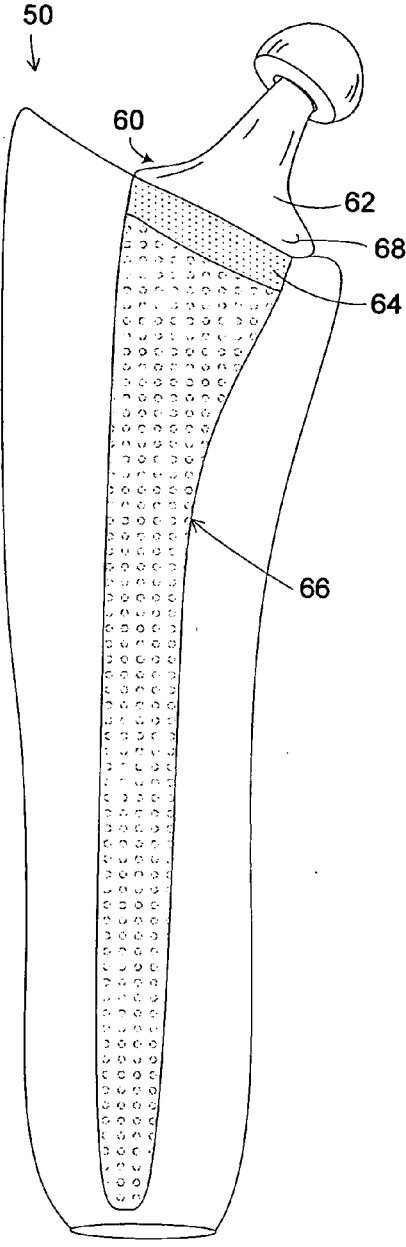

Fig. 4

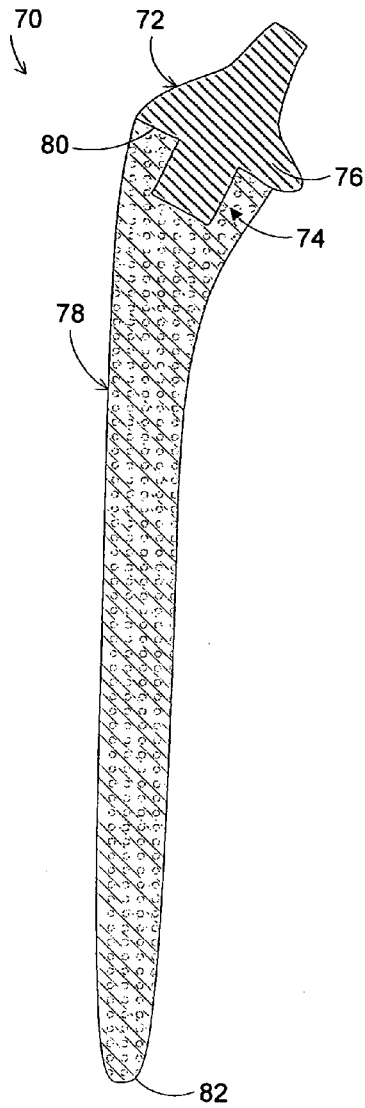

Fig. 5

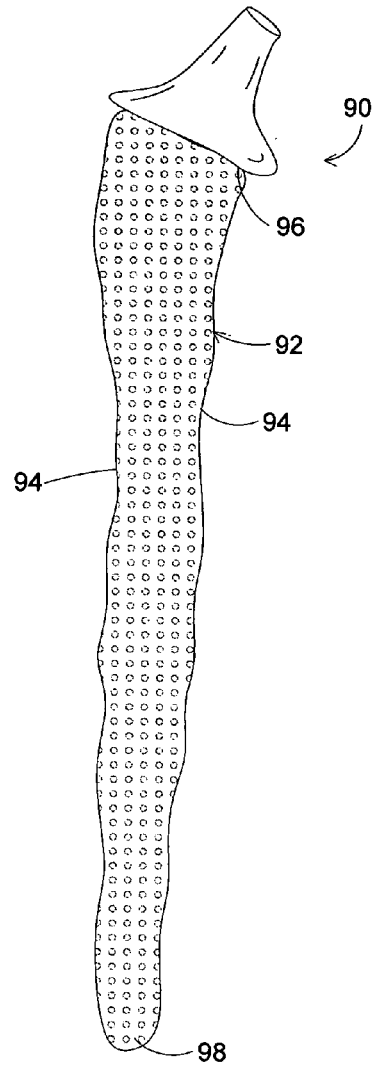

Fig. 6

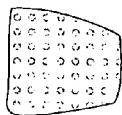

Fig. 7

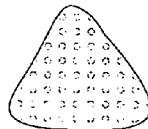

Fig. 8

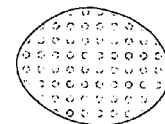

Fig. 9

1

HIP IMPLANT WITH POROUS BODY

This application is a continuing application of Ser. No. 10/446,069 filed on May 27, 2003 now abandoned and entitled "Hip Implant with Porous Body."

FIELD OF THE INVENTION

The disclosure herein generally relates to hip implants for osseointegration into bone and, more particularly, to hip implants having a porous body.

BACKGROUND OF THE INVENTION

Much effort has been directed to integrating hip implants into surrounding bone. Ideally, a hip implant would be placed into the femur, and thereafter bone would readily grow into the surface of the implant. To achieve this objective, many different surface technologies have been applied to hip implants. In some instances, the surface of the implant is roughened, grit-blasted, plasma-sprayed, or microtextured. In other instances, the surface is coated with a biological agent, such as hydroxylapatite (known as HA). In all of these instances, the goal is the same: Produce a surface on the hip implant into which surrounding bone will grow or bond.

Porous coatings have also been applied to surfaces of hip implants. These coatings are advantageous since bone will indeed grow into a portion of the outer most surface of the implant. Osseointegration, to a limited extent then, has been achieved with porous coated surfaces. These surfaces though are far from ideal in terms of accepting and encouraging bone growth into the body of the implant.

As one disadvantage, porous surfaces are often thin coatings applied to the metallic substrate of the implant. Bone surrounding the implant can only grow into the thin coating itself. Bone cannot grow through the coating and into the metallic substrate. The depth of bone growth into the implant is limited to the depth of the porous coating. Bone simply cannot grow completely through the implant or deeply into the body of the implant.

It therefore would be desirable to have a hip implant that offers optimum anchoring in bone with bone growth into a porous body.

SUMMARY OF THE INVENTION

The present invention is directed toward a femoral hip implant for integrating with surrounding bone. In one exemplary embodiment, the implant includes two separate and distinct bodies, a neck body and a bone fixation body. Together, these bodies form a complete femoral hip implant.

The neck body is located at the proximal end of the implant and includes an interface adapted to connect with a femoral ball component. In an exemplary embodiment, this interface comprises an elongated cylindrical shaft or neck adapted to matingly engage with a cylindrical recess in the femoral ball component.

In one exemplary embodiment, the neck body is formed of a solid metal piece, such as titanium, titanium alloy, or other metals or alloys suitable for a hip prosthesis. The body is formed from a machining process and has a base portion that may comprise a collar. The neck extends outwardly away from the base portion.

The bone fixation body is formed of a porous metal, such as titanium or other metals or alloys suitable for a hip prosthesis. In one exemplary embodiment, the body is formed with a sintering process, is completely porous, and does not include

2

a metal substrate. In cross section then, the body has a porous structure with no solid metal substrate.

The neck body (formed of solid metal) and the bone fixation body (formed of a completely porous structure) are permanently connected together. When connected, the two bodies form a hip implant. In one exemplary embodiment, these two bodies are connected with a sintering process.

In one exemplary embodiment, the bone fixation body portion of the hip implant is completely porous. This porous structure extends entirely through the body of the implant along the region where the implant engages femoral bone. As such, the depth of bone growth into the implant is not restricted to a thin porous coating. Instead, bone can grow deeply into the body of the implant or completely into and even through the body of the implant. The implant, then, can become fully integrated into surrounding bone with the structure of bone dispersed throughout the body of the implant.

In one exemplary embodiment, the geometric structure of the porous body may be shaped and sized to emulate the shape and size of natural bone surrounding the implant. Specifically, the porous structure of the bone fixation body thus replicates the porous structure of natural bone itself. The porous structure, thus, readily accepts and encourages surrounding bone to grow into and even through the body of the implant.

In one exemplary embodiment, the bone fixation body may be doped with bone growth agents to enhance and stimulate bone growth. These agents can be placed throughout the bone fixation body so bone grows deeply into the implant or completely through the implant. Bone growth, as such, is not restricted to the surface of the implant.

As noted, the porous structure of the implant enables bone to grow deeply into or completely through the implant itself. Growth deep into the body of the implant provides an extremely strong interface between the implant and surrounding natural bone. As such, the likelihood that the implant will loosen is greatly reduced. Further, the overall long-term acceptance of the implant in the bone is increased. Further yet, the porous structure of the bone fixation body reduces the overall weight of the hip implant.

BRIEF DESCRIPTION OF THE DRAWINGS

FIG. 1 is a side view of one embodiment of a hip implant of an exemplary embodiment of the present invention.

FIG. 2 is a cross-sectional view of the implant of FIG. 1 embedded in the intramedullary canal of a femur.

FIG. 3 is a side view of another exemplary embodiment of a hip implant of the present invention.

FIG. 4 is a cross-sectional view of FIG. 3 showing the hip implant embedded in the intramedullary canal of a femur.

FIG. 5 is a side cross-sectional view of yet another exemplary embodiment of a hip implant of the present invention.

FIG. 6 is a side view of yet another exemplary embodiment of the present invention.

FIG. 7 is a top view of a horizontal cross section of an exemplary embodiment of the present invention.

FIG. 8 is a top view of a horizontal cross section of another exemplary embodiment of the present invention.

FIG. 9 is a top view of a horizontal cross section of yet another exemplary embodiment of the present invention.

DETAILED DESCRIPTION

Referring to FIGS. 1 and 2, a hip implant 10 is shown according to an exemplary embodiment of the invention. Implant 10 is preferably constructed of a biocompatible mate-

rial such as titanium, titanium alloy, or other metals or alloys suitable for a hip prosthesis. Implant **10** comprises two primary components or bodies, a neck body **14** and a bone fixation body **16**.

The neck body **14** is located at the proximal end **18** of the hip implant **10** and functions to connect the hip implant **10** to a spherically shaped femoral ball **19** and acetabular component (not shown). The neck body extends from a flat or planar distal end surface **21** to a proximal end surface **23**. Further, the neck body has a base portion **20** that includes a collar **22** adapted to seat against a resected or end portion of a femur. An interface is adapted to connect the neck body to the femoral ball. A neck portion **24** extends outwardly from the base portion **20**. This neck portion has a short cylindrical configuration and has an end **26** with a slight taper. This end **26** is adapted to be received in a correspondingly shaped and sized cylindrical recess **30** in the femoral ball **19**. Together, end **26** and recess **30** form a Morse taper connection.

Preferably, the neck body **14** is formed of a biocompatible metal, such as a solid metal piece of titanium, titanium alloy or other metals or alloys suitable for a hip prosthesis. The body can be machined to have a size and shape shown in the figures or other sizes and shapes adapted for use as a hip implant.

The bone fixation body **16** has an elongated tapering shape that extends from a flat or planar proximal end surface **40** to a rounded distal end surface **42**. The distal end surface **21** of neck body **14** connects or fuses to the proximal end surface **40** of the bone fixation body **16** at a junction **44**.

In the exemplary embodiments of FIGS. **1** and **2**, bone fixation body **16** is formed from a porous metal, such as titanium. The body has a completely porous structure that extends throughout the entire body from the proximal end surface **40** to distal end surface **42**. Specifically, as shown in FIG. **2**, body **16** does not include a solid metal substrate.

FIG. **2** shows the implant **10** embedded in a femur **50** of a patient. In this embodiment, the implant is embedded into the intramedullary canal **52** of the femur. The length of the bone fixation body **16** extends along the region where the implant contacts surrounding bone. As shown, the collar **22** seats against a resected end **56** of the femur above an entrance **57** to the intramedullary canal **59**. In this embodiment, the bone fixation body **16** extends into the intramedullary canal, and the neck body **14** extends outwardly from the resected end of the intramedullary canal and femur. Further, the proximal end surface **40** is adjacent the entrance **57** to the intramedullary canal.

As noted, the bone fixation body **16** has a porous structure that extends throughout the body from the proximal end surface to the distal end surface. By "porous," it is meant that the material at and under the surface is permeated with interconnected interstitial pores that communicate with the surface. The porous structure can be formed by sintering titanium, titanium alloy powder, metal beads, metal wire mesh, or other suitable materials, metals, or alloys known in the art.

The porous structure of body **16** is adapted for the ingrowth of cancellous and cortical bone spicules. In the exemplary embodiment, the size and shape of the porous structure emulates the size and shape of the porous structure of natural bone. Preferably, the average pore diameter of body **16** is about 40 μm to about 800 μm with a porosity from about 45% to 65%. Further, the interconnections between pores can have a diameter larger than 50-60 microns. In short, the geometric configuration of the porous structure should encourage natural bone to migrate and grow into and throughout the entire body **16**.

Although specific ranges are given for pore diameters, porosity, and interconnection diameters, these ranges are exemplary and are applicable to one exemplary embodiment. In other embodiments, these ranges could be modified, and the resulting hip implant still within the scope of the invention.

Preferably, body **16** is created with a sintering process. One skilled in the art will appreciate that many variations exist for sintering, and some of these variations may be used to fabricate the present invention. In the exemplary embodiment, the neck body is formed from a solid piece of metal and prepared using conventional and known machining techniques. Next, a ceramic mold is provided. The mold has a first cavity that is sized and shaped to match the size and shape of the bone fixation body. In this first cavity, the sintering material can be placed. The mold also has a second cavity that is adjacent and connected to the first cavity. This second cavity is sized and shaped to receive the neck body. The neck body is positioned in the second cavity such that the distal end surface is adjacent and continuous with the first cavity.

The sintering material is then placed into the first cavity. This material may be a titanium alloy powder, such as Ti-6Al-4V. Some of this powder will contact the distal end surface of the neck body. The mold is then heated to perform the sintering process. During this process, as the material in the first cavity heats and sinters, the bone fixation body forms and simultaneously bonds or fuses to the distal end surface of the neck body.

The size and shape of the pores and porous structure produced in the first cavity depend on many factors. These factors include, for example, the temperature obtained in the furnace, the sintering time, the size and shape of sintering material, the composition of the sintering material, and the type of ceramic mold used. These factors (and others) can be varied to produce a bone fixation body in accordance with the present invention. Further, these factors (and others) can be varied to produce a strong bond between the bone fixation body and neck body.

Once the sintering process is finished, the neck body is directly fused to the bone fixation body. These two bodies are now permanently connected together to form the hip implant.

In the aforementioned sintering process, the bone fixation body simultaneously forms and attaches to the neck body. One skilled in the art though will appreciate that each of these bodies can be fabricated independently and subsequently connected together. If the bodies are made separately, then they may be attached or fused together using known welding or brazing techniques, for example.

In FIG. **1**, for example, the bone fixation body has an elongated tapering body with a slight bow. The bone fixation body, though, may have other configurations and still be within the scope of the invention. The size and shape of the body depend on the size and shape of the cavity of the mold during the sintering process. This cavity can be shaped, for example, to emulate the natural size, shape, and contour of a human intramedullary canal. As such, the bone fixation body will more naturally fit into the intramedullary canal and conform to the natural anatomical contours of a human patient.

FIGS. **3** and **4** show another hip implant **50** according to an exemplary embodiment of the invention. With some differences, implant **50** is similarly configured to the implant **10**. As one difference, the neck body **60** of implant **50** has two different and distinct regions on its outer surface. A first region **62** has a smooth outer surface. A second region **64** has a bone-engaging surface that is contiguous and adjacent to the first region **62** on one side and contiguous and adjacent to the porous bone fixation body **66** on the other side. The second

5

region is non-porous and is shaped as a band that extends completely around the neck body. This second region can be formed on the outer surface of the neck body with various techniques. These techniques include, for example, coating with HA, grit-blasting, etching, micro-texturing, other non-porous surface treatments, or combinations of these techniques. This surface **64** is provided as an intermediate zone between the porous body and the smooth first region **62**.

As shown in FIG. 4, the second region **64** is below collar **68** and is positioned into the intramedullary canal to contact bone. Region **64**, then, contacts bone, and region **62** does not contact bone and extends above it.

FIG. 5 shows another implant **70** according to another exemplary embodiment of the invention. With some differences, implant **70** is similarly configured to the implant **10**. As one difference, neck body **72** includes a male protrusion **74** that extends outward from base portion **76**. This protrusion **74** is adapted to extend partially into the bone fixation body **78** of implant **70**.

The protrusion **74** forms a core for the bone fixation body. As shown in FIG. 5, this protrusion extends past the proximal end surface **80** and into the bone fixation body. The depth of the protrusion into the bone fixation body can be increased or decreased in various embodiments and still remain within the scope of the invention. For example, the protrusion can partially extend into the bone fixation body and remain substantially near the proximal end surface. Alternatively, the protrusion can extend farther into the bone fixation body toward the distal end surface **82**. In this latter embodiment, the protrusion gradually tapers as it extends toward the distal end surface.

The size and shape of the protrusion can also have various embodiments and still remain within the scope of the invention. For example, the protrusion can be cylindrical or polygonal, such as rectangular or square. Other configurations are possible as well; the protrusion can taper or have longitudinal ribs placed along its outer surface. The size and shape of the protrusion can have various embodiments to serve various functions. For example, the protrusion can be sized and shaped to provide a strong connection between the neck body and bone fixation body. The protrusion can be sized and shaped to provide an anti-rotational interface between the neck body and bone fixation body. Further, the protrusion can be sized and shaped to provide additional strength to the bone fixation body or more equally or efficiently distribute loads from the neck body to the bone fixation body. Other factors as well may contribute to the design of the protrusion.

FIG. 6 shows another implant **90** according to an exemplary embodiment of the invention. Implant **90** has a bone fixation body **92** with an outer surface that has a plurality of undulations **94**, such as hills and valleys. These undulations may be provided as tiny ripples or waves. Alternatively, the undulations may be larger and more rolling. Regardless, the undulations are adapted to firmly secure the implant into the intramedullary canal of the femur after the implant is placed therein.

As shown in FIG. 6, the undulations extend along the entire length of the bone fixation body **92** from the proximal end surface **96** to the distal end surface **98**. In alternative embodiments, the undulations do not extend along the entire length of the bone fixation body, but partially extend along this body.

FIGS. 7-9 show various longitudinal cross-sectional shapes of the bone fixation body for different exemplary embodiments of the invention. The bone fixation body may have one single longitudinal cross-sectional shape, or the

6

body may have numerous different longitudinal cross-sectional shapes. FIGS. 7-9 represent examples of some of these shapes.

FIG. 7 shows a trapezoidal longitudinal cross-sectional shape. FIG. 8 shows a triangular longitudinal cross-sectional shape. FIG. 9 shows an elliptical or oval longitudinal cross-sectional shape.

The bone fixation body can be adapted to induce bone growth partially into or entirely through the body. The body, for example, can be doped with biologically active substances. These substances may contain pharmaceutical agents to stimulate bone growth all at once or in a timed-release manner. Such biological active substances are known in the art.

Although illustrative embodiments have been shown and described, a wide range of modifications, changes, and substitutions is contemplated in the foregoing disclosure; and some features of the embodiments may be employed without a corresponding use of other features. Accordingly, it is appropriate that the appended claims be construed broadly and in a manner consistent with the scope of the embodiments disclosed herein.

What is claimed is:

1. A hip implant, comprising:

a neck body having a proximal end that connects with an acetabular component, having a distal end surface with an elongated protrusion that extends outwardly therefrom, and being formed of solid metal; and

a bone fixation body having an elongated tapering shape and being formed as a completely porous metal structure that extends throughout an exterior and an interior of the bone fixation body and that includes a proximal end that engages the distal end surface of the neck body at an interface,

wherein the interface has a trapezoidal cross-sectional shape in which the trapezoidal cross-sectional shape continues and tapers in a distal direction toward a distal end of the bone fixation body,

wherein the bone fixation body is made separately from the neck body, and the bone fixation body is bonded to the neck body after the bone fixation body is made separately from the neck body,

wherein the elongated protrusion of the neck body forms a core for the bone fixation body and tapers and extends into an opening of the bone fixation body such that the porous metal structure completely surrounds and engages an exterior surface of the elongated protrusion that extends into the bone fixation body,

wherein the elongated protrusion is shaped to provide an anti-rotational interface between the neck body and the bone fixation body, and

wherein the porous structure of the bone fixation body has a size and a shape that emulate a size and a shape of a porous structure of natural human bone.

2. A hip implant, comprising:

a neck body having a proximal end engageable with an acetabular component, having a distal end surface with an elongated protrusion that extends outwardly therefrom, and being formed of solid metal; and

a bone fixation body having an elongated shape that tapers from a proximal end to a distal end, being formed as a completely porous metal structure in which the porous metal structure extends throughout an exterior and an interior of the bone fixation body and extends from the proximal end to the distal end, and having the proximal end of the bone fixation body engaged with the distal end surface of the neck body at an interface,

7

wherein the interface has a trapezoidal cross-sectional shape in which the trapezoidal cross-sectional shape continues and tapers in a distal direction toward the distal end of the bone fixation body;

wherein the elongated protrusion of the neck body tapers and extends into an opening of the bone fixation body such that the porous metal structure surrounds and engages an exterior surface of the elongated protrusion that extends into the bone fixation body,

wherein the bone fixation body is formed separately from the neck body and then is bonded with the neck body at the interface and at the exterior surface of the elongated protrusion,

wherein the elongated protrusion forms a core for the bone fixation body and has a non-circular shape that is shaped to provide an anti-rotational interface between the neck body and the bone fixation body, and

wherein the porous structure of the bone fixation body emulates a porous structure of natural human bone.

3. A hip implant, comprising:

a neck body that is solid metal and includes a proximal end that engages with an acetabular component and a base portion with a male protrusion that extends outwardly from the base portion; and

a bone fixation body that includes an elongated shape that tapers, is formed as a porous metal structure in which the completely porous metal structure extends throughout an exterior and an interior of the bone fixation body and

8

extends from a proximal end that engages the base portion of the neck body at an interface to a distal end of the bone fixation body,

wherein the interface has a trapezoidal cross-sectional shape in which the trapezoidal cross-sectional shape continues and tapers in a distal direction toward the distal end of the bone fixation body,

wherein the male protrusion of the neck body extends into an opening of the bone fixation body such that the porous metal structure surrounds and engages an exterior surface of the male protrusion that extends into the bone fixation body,

wherein the bone fixation body is made separately from the neck body and then attached to the neck body at the interface and at the exterior surface of the male protrusion,

wherein the male protrusion forms a core for the bone fixation body,

wherein the male protrusion is shaped to provide an anti-rotational interface between the neck body and the bone fixation body, and

wherein the porous structure of the bone fixation body emulates a porous structure of natural human bone.

4. The hip implant of claim 3, wherein the male protrusion extends toward a distal end surface of the bone fixation body, and gradually tapers as it extends toward the distal end surface of the bone fixation body.

* * * * *