

UNITED STATES PATENT AND TRADEMARK OFFICE

BEFORE THE PATENT TRIAL AND APPEAL BOARD

VARIAN MEDICAL SYSTEMS, INC.,
Petitioner,

v.

WILLIAM BEAUMONT HOSPITAL,
Patent Owner.

Case IPR2016-00163
Patent 6,842,502 B2

Before MICHAEL W. KIM, KALYAN K. DESHPANDE, and
MATTHEW R. CLEMENTS, *Administrative Patent Judges*.

CLEMENTS, *Administrative Patent Judge*.

FINAL WRITTEN DECISION
35 U.S.C. § 318(a) and 37 C.F.R. § 42.73

I. INTRODUCTION

A. *Background*

Varian Medical Systems, Inc. (“Petitioner”) filed a Petition to institute an *inter partes* review of claims 43–46, 48–55, 57, 59–66, and 68 of U.S. Patent No. 6,842,502 B2 (Ex. 1201, “the ’502 Patent”). Paper 1 (“Pet.”). William Beaumont Hospital (“Patent Owner”) filed a Preliminary Response. Paper 11 (“Prelim. Resp.”).

On May 6, 2016, we instituted an *inter partes* review of claims 43–46, 48–55, 57, 59–66, and 68 based on the two grounds of unpatentability set forth in the Petition. Paper 14 (“Dec.”). After institution of trial, Patent Owner filed a Patent Owner Response (Paper 25, “PO Resp.”) and Petitioner filed a Reply (Paper 50, “Pet. Reply”).¹ Petitioner relies on the Declarations of James Balter, Ph.D. (Exs. 1202, 1500). Patent Owner relies on the Declaration of Ali Bani-Hashemi, Ph.D. (Ex. 2080). Patent Owner also filed a Motion to Exclude (Paper 59, “PO Mot.”), to which Petitioner filed an Opposition (Paper 65, “Pet. Opp.”) and Patent Owner filed a Reply (Paper 69, “PO Reply”).

An oral hearing was held on January 31, 2017. Paper 76 (“Tr.”).

After the oral hearing, we authorized additional briefing on the proper claim construction of the phrase “wherein said computer receives said image of said object and based on said image sends a signal to said radiation source that controls said path of said radiation source,” recited in claim 1. Paper 75.

¹ Petitioner’s Motion to Seal (Paper 49) was granted in our Order of January 3, 2017 (Paper 56). Unless otherwise indicated, all references herein to the Reply will be to the public version (Paper 51).

Patent Owner filed a Response (Paper 77) and Petitioner filed a Response (Paper 78).

The Board has jurisdiction under 35 U.S.C. § 6. In this Final Written Decision, issued pursuant to 35 U.S.C. § 318(a) and 37 C.F.R. § 42.73, we determine that Petitioner has not met its burden of showing, by a preponderance of the evidence, that any claim for which trial was instituted is unpatentable. Patent Owner's Motion to Exclude is *denied*.

B. Related Proceedings

Petitioner and Patent Owner identify the following district court proceedings concerning the '502 Patent: *Elekta Ltd. and William Beaumont Hosp. v. Varian Med. Sys.*, Case No. 2:15-cv-12169-AC-MKM (E.D. Mich.). Pet. 1; Paper 9, 1. Petitioner and Patent Owner identify further the following *inter partes* reviews also directed to the '502 Patent: IPR2016-00160, IPR2016-00162, and IPR2016-00166. Pet. 1; Paper 9, 2. Patent Owner identifies additionally the following *inter partes* reviews directed to U.S. Patent No. 7,471,765 B2, which claims priority to the '502 Patent: IPR2015-00169, IPR2016-00170, and IPR2016-00171. Paper 9, 2. Patent Owner identifies also the following *inter partes* review directed to U.S. Patent No. 7,826,592 B2, which claims priority to the '502 Patent: IPR2016-00187. Paper 9, 3.

C. The '502 Patent

The '502 Patent discloses that it is directed to a cone-beam computed tomography ("CBCT") system that employs an amorphous silicon flat-panel imager ("FPI") for use in radiotherapy applications where images of a patient are acquired with the patient in a treatment position on a treatment table. Ex. 1201, 1:11–17. Figure 17(b) (below) depicts a diagrammatic

view of one orientation of an exemplary wall-mounted cone beam computerized tomography system employing a flat-panel imager. Ex. 1201, 6:53–56.

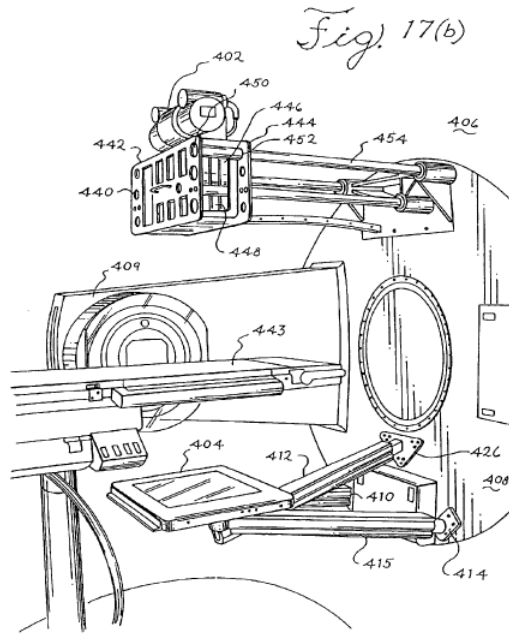

Specifically, Figure 17(b) depicts wall-mounted cone beam computerized tomography system 400 includes an x-ray source, such as x-ray tube 402, and flat-panel imager 404 mounted on gantry 406. Ex. 1201, 19:64–67. X-ray tube 402 generates beam of x-rays 407 in a form of a cone or pyramid. Ex. 1201, 19:67–20:2. Flat-panel imager 404 employs amorphous silicon detectors. Ex. 1201, 20:6–7.

D. Illustrative Claims

Petitioner challenges claims 43–46, 48–55, 57, 59–66, and 68 of the '502 Patent. Claims 43 and 60 are the only independent claims at issue, and are reproduced below:

43. A method of treating an object with radiation, comprising:
 - move a radiation source about a path;

direct a beam of radiation from said radiation source towards an object;

emitting an x-ray beam in a cone beam form towards an object;

detecting x-rays that pass through said object due to said emitting an x-ray beam with a flat-panel imager;

generating an image of said object from said detected x-rays,

wherein said generating comprises forming a computed tomography image of said object based on said detected x-rays,

wherein said image contains at least three dimensional information of said object based on one rotation of said x-ray source around said object; and

controlling said path of said radiation source based on said image.

60. A method of treating an object with radiation, comprising:

move a radiation source about a path;

direct a beam of radiation from said radiation source towards an object;

emitting an x-ray beam in a cone beam form towards an object;

detecting x-rays that pass through said object due to said emitting an x-ray beam with a flat-panel imager; generating an image of said object from said detected x-rays,

wherein said generating comprises forming a computed tomography image of said object based on said detected x-rays,

wherein said image contains at least three dimensional information of said object based on one rotation of said x-ray source around said object; and

controlling a radiation therapy treatment plan involving said radiation source based on said image.

E. Instituted Grounds of Unpatentability

We instituted *inter partes* review of claims 43–46, 48–55, 57, 59–66, and 68 on the following grounds.

Reference(s)	Basis	Challenged Claims
Jaffray 1999 SPIE, ² Jaffray 1999 JRO, ³ Adler, ⁴ and Depp ⁵	§ 103(a)	43–46, 48–55, 57, 59
Jaffray 1999 SPIE, Jaffray 1999 JRO, Adler, Depp, and Yan ⁶	§ 103(a)	60–66, 68

II. ANALYSIS

A. Claim Construction

In an *inter partes* review, a claim in an unexpired patent shall be given its broadest reasonable construction in light of the specification of the patent in which it appears. 37 C.F.R. § 42.100(b); *see also* *Cuozzo Speed Techs., LLC v. Lee*, 136 S.Ct. 2131, 2142 (2016) (affirming that USPTO has statutory authority to construe claims according to 37 C.F.R. § 42.100(b)). Under the broadest reasonable construction standard, claim terms are given their ordinary and customary meaning, as would be understood by one of

² D.A. Jaffray et al., *Performance of a Volumetric CT Scanner Based Upon a Flat-Panel Imager*, SPIE, 3659:204–14 (Feb. 1999) (Ex. 1205, “Jaffray 1999 SPIE”).

³ D.A. Jaffray et al., *A Radiographic and Tomographic Imaging System Integrated into a Medical Linear Accelerator for Localization of Bone and Soft-Tissue Targets*, Int. J. Radiation Oncology Biol. Phys., 45:773–89 (Oct. 1999) (Ex. 1206, “Jaffray 1999 JRO”).

⁴ U.S. Patent No. 5,207,223, issued May 4, 1993 (Ex. 1203).

⁵ U.S. Patent No. 5,427,097, issued June 27, 1995 (Ex. 1204).

⁶ D. Yan et al., *The Use of Adaptive Radiation Therapy to Reduce Setup Error: A Prospective Clinical Study*, Int’l J. Radiation Oncology Biol. Phys., 41:715–20 (1998) (Ex. 1207, “Yan”).

ordinary skill in the art in the context of the entire disclosure. *In re Translogic Tech., Inc.*, 504 F.3d 1249, 1257 (Fed. Cir. 2007). Any special definition for a claim term must be set forth in the specification with reasonable clarity, deliberateness, and precision. *In re Paulsen*, 30 F.3d 1475, 1480 (Fed. Cir. 1994). We must be careful not to read a particular embodiment appearing in the written description into the claim if the claim language is broader than the embodiment. *In re Van Geuns*, 988 F.2d 1181, 1184 (Fed. Cir. 1993). Only terms which are in controversy need to be construed, and then only to the extent necessary to resolve the controversy. *Vivid Techs., Inc. v. Am. Sci. & Eng'g, Inc.*, 200 F.3d 795, 803 (Fed. Cir. 1999).

Petitioner proposes constructions for “based on one rotation,” “three dimensional information,” and “a computer . . . that controls said path of said radiation source.” Pet. 12–14. In our Decision on Institution, we determined that it was necessarily to construe only “three dimensional information.” Dec. 6–8. Patent Owner contests our construction of “three dimensional information.” PO Resp. 11–14. Specifically, Patent Owner contends that “three dimensional information” must be construed in the context of the claim phrase “a computed tomography image of said object based on said detected x-rays, wherein said image contains at least three dimensional information of said object based on one rotation of said x-ray source around said object,” as recited in independent claims 43 and 60. *Id.*

In addition, after oral argument, we authorized briefing on the correct construction of “wherein said computer receives said image of said object and based on said image sends a signal to said radiation source that controls

said path of said radiation source.”⁷ Paper 75. Both parties submitted briefing. Papers 77, 78.

For purposes of this Decision, we determine that it is necessary to construe only (1) the claim phrase containing “three dimensional information;” and (2) “controlling [said path of / a radiation therapy treatment plan involving] said radiation source based on said image.”

1. *“a computed tomography image of said object based on said detected x-rays, wherein said image contains at least three dimensional information of said object based on one rotation of said x-ray source around said object”*

Independent claims 43 and 60 each recite “a computed tomography image of said object based on said detected x-rays, wherein said image contains at least three dimensional information of said object based on one rotation of said x-ray source around said object.” Petitioner asserts that “three dimensional information” should be construed as “information concerning three dimensions of an object (such as length, width, and depth).” Pet. 14 (citing Ex. 1201, 3:40–43; Ex. 1202 ¶ 37); Pet. Reply 1–5 (citing Exs. 1500 ¶¶ 7–23⁸; 1502, 78:22–80:16, 83:14–87:11, 135:10–

⁷ Independent claim 43 recites a commensurate limitation: “controlling said path of said radiation source based on said image.” Independent claim 60 recites a commensurate limitation: “controlling a radiation therapy treatment plan involving said radiation source based on said image.”

⁸ In evaluating the assertions set forth in the Declaration of James Balter Ph.D. in Support of Petitioner’s Reply (Ex. 1500), we considered Patent Owner’s Motion for Observations on the Cross-Examination of Dr. James Balter (Paper 58) and Petitioner’s Response to Patent Owner’s Motion for Observations on Cross-Examination (Paper 66).

136:11).⁹ Patent Owner asserts that the aforementioned claim limitation, in its entirety, should be construed as “a volumetric image of an object generated by reconstructing 2-D projection images.” PO Resp. 11–14 (citing Ex. 1201, 1:37–42, 1:45–54, 2:42–48, 2:51–55, 3:40–43, 3:54–55, 5:6–10, 16:43–45, 16:58–62; Ex. 2080 ¶¶ 88–93). We agree with Petitioner.

We begin first with the claim language, and note that “three-dimensional information” appears facially to be co-extensive with any information relevant to three-dimensions. We discern that “length, width, and depth” are just such information. We have considered Patent Owner’s above-cited portions of the ’502 Patent, but are unpersuaded that those portions narrow “three-dimensional information” with sufficient “reasonable clarity, deliberateness, and precision” such that one of ordinary skill would have understood “three-dimensional information” as co-extensive with Patent Owner’s proffered construction. *In re Paulsen*, 30 F.3d 1475, 1480 (Fed. Circ 1994). For example, column 2, lines 42–48 and 51–55 certainly disclose that “volume” is desirable, but does not provide any equivalence between “three-dimensional information” and “volume.” Indeed, column 2, lines 54–55 disclose “provide information regarding the location of soft-tissue target volumes,” indicating that “information” is a subset of “volume.” In another example, column 3, lines 40–43, mentions “three-dimensional (3-D) images,” which we agree would appear to require “volumetric data”; however, the claim limitation at issue is the broader term “three-dimensional information.” In a further example, column 9, line 62, through column 10, line 5, clearly refers to “volumetric data,” but does not indicate its relation to

⁹ In the Decision on Institution, we preliminarily agreed with Petitioner’s proposed construction of “three-dimensional information.” Dec. 7–8.

“three-dimensional information.” In yet another example, column 16, lines 43–45 and 58–62, do not recite “three-dimensional information,” instead disclosing “3-D structure” and “3-D nature” in relation generally to “volumetric data,” but, again, not in a manner sufficient to indicate a particular relationship.

Finally, in regards to assertions set forth in the Declaration of Dr. Hashemi, we discern some merit in his assertion that when reading the claim limitation “three-dimensional information” in conjunction with another claim limitation “cone-beam computed tomography,” “a CBCT image is a volumetric image that provides the location, shape, and spatial orientation of the target volume in all directions, not just its length, width, and depth.” Ex. 2080 ¶ 91. The claim limitation at issue, however, reads “an image of said object, wherein said image contains *at least* three-dimensional information of said object based on one rotation of said x-ray source around said object” (emphasis added). Accordingly, the claim limitation does not preclude an image having *more* information than “information concerning three dimensions of an object (such as length, width, and depth),” such as “a volumetric image of an object generated by reconstructing 2-D projection images.” Under Patent Owner’s construction, however, the image would be *required* to have such information. We are unpersuaded that such information is required under a proper construction of “three-dimensional information” for the reasons set forth *supra*.

We construe “three-dimensional information” as “information concerning three dimensions of an object (such as length, width, and depth).”

2. *“controlling [said path of/ a radiation therapy treatment plan involving] said radiation source based on said image.”*

Independent claim 43 recites “controlling said path of said radiation source based on said image,” and independent claim 60 recites “controlling a radiation therapy treatment plan involving said radiation source based on said image.”

Petitioner asserts that “[a person of ordinary skill in the art] would understand this claim language to encompass both a computer system operated by a user and a system that autonomously carries out the recited control function.” Paper 78, 1. Patent Owner agrees that “based on the intrinsic evidence and basic principles of claim construction, the relevant limitation of claim 1 of the ’502 patent should be construed to encompass a computer configured to permit human operation to perform the recited control function.”¹⁰ Paper 77, 5.

Both parties agree that this construction is supported by both the intrinsic evidence and the extrinsic evidence. Paper 78, 1–5 (citing Ex. 1201, Abstract, 4:57–62, claim 1, claim 34; Ex. 1500 ¶¶ 32–34; Ex. 1502, 120:14–121:11; IPR2016-00160, Ex. 2080 ¶¶ 61–65, 99, 112–116, 127); Paper 77, 1–5 (citing Ex. 1201, 26:39–55, claim 1; Ex. 1212, 125–26; Tr. 31:1–33:13; Ex. 2080 ¶ 99; Ex. 2084, WBH_Elekta_01890, WBH_Elekta_01920, WBH_Elekta_01948, WBH_Elekta_01971; IPR2016-00162, Paper 66, 44:22–45:13). In particular, both parties agree that claim 1 is open-ended and non-limiting, and is necessarily broader than dependent

¹⁰ Patent Owner’s briefing addresses the commensurate limitation recited in claim 1, but neither party argues, and we discern no reason why, the limitations recited in claims 43 and 60 should be construed to have a scope different than the limitation recited in claim 1.

claim 34, which specifies that the recited control of said radiation path is “in an automatic manner *without human intervention*.” The same reasons apply to independent claims 43 and 60. Both are open-ended and non-limiting, and both are necessarily broader than their respective dependent claims, 58 and 69, which specify that the recited controlling “is performed automatically and without human intervention.”

We agree. We, therefore, construe “controlling [said path of / a radiation therapy treatment plan involving] said radiation source based on said image” to encompass a person or user operating the computer to perform the recited control functions.

B. Level of Ordinary Skill in the Art

Dr. Balter, Petitioner’s expert, proffers that a hypothetical person of ordinary skill in the art, with respect to and at the time of the ’502 patent, would have the following qualifications: “a medical physicist with a Ph.D. (or similar advanced degree) in physics, medical physics, or a related field, and two or more years of experience in radiation oncology physics and image processing/computer programming related to radiation oncology applications.” Ex. 1202 ¶ 13. Dr. Hashemi, Patent Owner’s expert, essentially agrees, with the only major differences to the above being that an M.S. is acceptable in lieu of a Ph.D., and that three years of experience is preferred. Ex. 2080 ¶ 17. Nominally, we accept Petitioner’s proffered level because it is based on Dr. Balter’s more complete explanation. We note, however, that neither party has explained substantively any significance that the difference in the proffered levels of ordinary skill in the art would play in the obviousness analysis. *See Graham v. John Deere Co.*, 383 U.S. 1, 17–18 (1966); *Okajima v. Bourdeau*, 261 F.3d 1350, 1355 (Fed. Cir. 2001) (“[T]he

level of skill in the art is a prism or lens through which a judge, jury, or the Board views the prior art and the claimed invention.”); *Ryko Mfg. Co. v. Nu-Star, Inc.*, 950 F.2d 714, 718 (Fed. Cir. 1991) (“The importance of resolving the level of ordinary skill in the art lies in the necessity of maintaining objectivity in the obviousness inquiry.”). To that end, we note that the prior art itself often reflects an appropriate skill level. *See Okajima*, 261 F.3d at 1355.

C. Whether Jaffray 1999 SPIE and Jaffray 1999 JRO are Prior Art to Claims 43–46, 48–55, 57, 59–66, and 68

Petitioner asserts that (1) claims 43–46, 48–55, 57, 59–66, and 68 are not entitled to the benefit of priority of the February 18, 2000 filing date of provisional application no. 60/183,590 (“the ’590 Application”), and, thus, Jaffray 1999 SPIE and Jaffray 1999 JRO are prior art under 35 U.S.C. § 102(b)¹¹ (Pet. 14–16; Reply 6–10); and (2) even if the claims are entitled to the benefit of the February 18, 2000, filing date of the ’590 Application, Jaffray 1999 SPIE and Jaffray 1999 JRO are still prior art under 35 U.S.C. § 102(a) (Pet. 18; Reply 10–20).

Patent Owner asserts that (1) the challenged claims are entitled to the benefit of priority of the February 18, 2000 filing date of the ’590 Application, and, thus, Jaffray 1999 SPIE and Jaffray 1999 JRO are not prior art under 35 U.S.C. § 102(b) (PO Resp. 14–28); and (2) Jaffray 1999 SPIE and Jaffray 1999 JRO are not prior art under 35 U.S.C. § 102(a), because the portions of Jaffray 1999 SPIE and Jaffray 1999 JRO upon which

¹¹ All references to 35 U.S.C. §§ 102, 103 herein will be pre-AIA.

Petitioner relies is the work of the named inventors of the '502 Patent, not of the coauthors not named as inventors (*id.* at 28–39).

We agree with Patent Owner for the reasons explained below.

1. Principles of Law

Petitioner has the burden of persuasion to prove unpatentability by a preponderance of the evidence. *Dynamic Drinkware, LLC v. Nat'l Graphics, Inc.*, 800 F.3d 1375, 1379 (Fed. Cir. 2015). Petitioner also has the initial burden of production to show that a reference is prior art to certain claims under a relevant section of 35 U.S.C. § 102. *Id.* Once Petitioner has met that initial burden, the burden of production shifts to Patent Owner to argue or produce evidence that the asserted reference is not prior art to certain claims, for example, because those claims are entitled to the benefit of priority of an earlier filed application. *Id.* at 1380. Once Patent Owner has met that burden of production, the burden is on Petitioner to show that the claims at issue are not entitled to the benefit of priority of the earlier filed application. *Id.*

Section 102(a) of 35 U.S.C. recites “[a] person shall be entitled to a patent unless . . . (a) the invention was known or used by others in this country, or patented or described in a printed publication in this or a foreign country, before the invention thereof by the applicant for patent.” “[O]ne’s own work is not prior art under § 102(a) even though it has been disclosed to the public in a manner or form which otherwise would fall under § 102(a).” *In re Katz*, 687 F.2d 450, 454 (Fed. Cir. 1982). Generally, “a patent is ‘to another’ when the ‘inventive entities’ are different.” *Application of Fong*, 378 F.2d 977, 980 (CCPA 1967); *see also In re Land and Rogers*, 368 F.2d 866, 877 (CCPA 1966) (“There appears to be no dispute as to the law that A

is not ‘another’ as to A, B is not ‘another’ as to B, or even that A & B are not ‘another’ as to A & B. But that is not this case, which involves, . . . , the question whether either A or B is ‘another’ as to A & B as joint inventors under section 102(e)’’).

What we have in this case is ambiguity created by the printed publication. The article does not tell us anything specific about inventorship, and appellant is only one of three authors who are reporting on scientific work in which they have all been engaged in some capacity at the Harvard Medical School. It was incumbent, therefore, on appellant to provide a satisfactory showing which would lead to a reasonable conclusion that he is the sole inventor.

In re Katz, 687 F.2d at 455 (footnote omitted).

2. *Whether Jaffray 1999 SPIE and Jaffray 1999 JRO are Prior Art to claims 43–46, 48–55, 57, 59–66, and 68 under 35 U.S.C. § 102(b)*

Applying the framework from *Dynamic Drinkware*, we determine that Petitioner has met its initial burden of production by asserting that independent claims 43 and 60 are not entitled to the benefit of priority of the ’590 Application, and, thus, that both Jaffray 1999 SPIE and Jaffray 1999 JRO are prior art under 35 U.S.C. § 102(b). Pet. 14–18. Specifically, Petitioner asserts that “the challenged claims require the claim element of controlling the path of a radiation source based on a three-dimensional image obtained through a single CBCT rotation” and that the ’590 Application does not provide sufficient written description support for that element because “the provisional application discloses a benchtop CBCT-FPI system” and “has no discussion of using the benchtop system to control a path of a radiotherapy beam.” *Id.* at 15; *see also id.* at 16 (“One of ordinary skill in the art, reviewing the ’590 [Application], would not have

recognized that the applicants possessed the invention they claimed.”). As a result, according to Petitioner, the effective date of independent claims 43 and 60 is February 16, 2001, the filing date of U.S. Application No. 09/788,335, which issued as the ’502 Patent. *Id.* at 16. Petitioner concludes that Jaffray 1999 SPIE and Jaffray 1999 JRO are each prior art under 35 U.S.C. § 102(b), because each has a publication date earlier than February 18, 2000. *Id.* at 17–18.

The burden of production having shifted to Patent Owner, Patent Owner asserts that independent claims 43 and 60 are entitled to the benefit of priority of the ’590 Application, because the ’590 Application provides sufficient written description support for the disputed limitations (“controlling said path of said radiation source based on said image” in claim 43, and “controlling a radiation therapy treatment plan involving said radiation source based on said image” in claim 60). PO Resp. 14–28 (citing *Polaris Wireless, Inc. v. TruePosition, Inc.*, Case No. IPR2013-00323, 2013 WL 8563953, at *17 (PTAB Nov. 15, 2013) (Paper 9) (“Patent Owner has to make a sufficient showing of entitlement to earlier filing date or dates, in a manner that is commensurate in scope with the specific points and contentions raised by Petitioner.”)). Specifically, Patent Owner identifies several portions of the ’590 Application that allegedly provide written description support for the aforementioned limitations of independent claims 43 and 60.

Patent Owner principally identifies the following portions: “[t]he specific geometries used in the discussion herein are shown in Figure 2, and are set to simulate the imaging geometry that would be implemented for a CBCT system incorporated on a radiotherapy treatment machine” (Ex. 1210,

7:13–16); “the host computer advances the motorized rotation stage” (Ex. 1210, 11:6); and “[a] CBCT system is proposed for radiotherapy guidance on a treatment-by-treatment basis using CT data obtained with a kV x-ray source and a large-area, indirect detection flat-panel imager (FPI). This imaging system can be installed on a conventional radiotherapy linear accelerator for application to image-guided radiation therapy” (Ex. 1210, 6:11–15). PO Resp. 19–20. In addition, Patent Owner identifies Figure 3 of the ’590 Application, and provides an annotated comparison, reproduced below, to Figure 17(c) of the ’502 Patent:

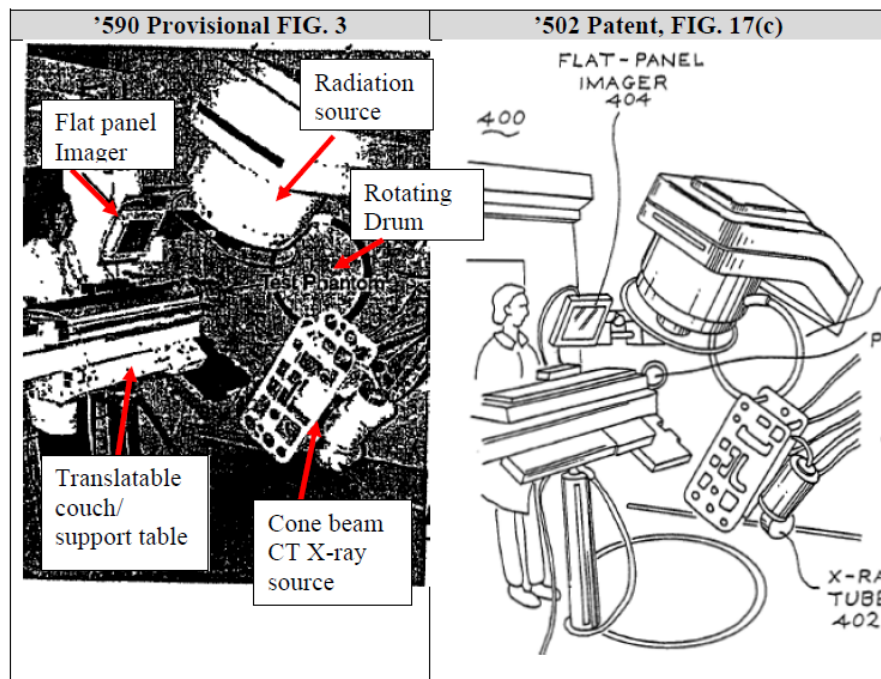

Id. at 21.

Patent Owner also argues that “it was well-known to a POSA at the time of the invention that conventional linear accelerators included computer-controlled support tables to position the patient (and thus guide the path of the radiation source)” (PO Resp. 25), and that “a [person of ordinary skill in the art] would have recognized that the disclosed drum-based Elekta

linear accelerator”—like that disclosed in Figure 3 of the ’590 Application—
“included a computer control system, which facilitated control of the
treatment couch to adjust the relative position of the patient and radiation
source” (PO Resp. 25–26 (citing Ex. 2080 ¶¶ 60–65, 104–110, 121–124);
see also id. at 26–27 (citing Ex. 2080 ¶¶ 59–60, 101, 106, 111–113, 124).
As a result, according to Patent Owner, a person of ordinary skill in the art
would have understood the ’590 Application’s disclosure of “image-guided
radiation therapy” (Ex. 1210, 6:14–15), “guiding radiation therapy on a
medical linear accelerator” (*id.* at 31:6–7), “on-line imaging and guidance”
(*id.* at 1:19), “on-line tomographic guidance” (*id.* at 2:18–19), and
“navigational imaging for therapies” (*id.* at 30:5–6) to

constitute an express disclosure of the process of imaging a target
tumor immediately prior to treatment, comparing the image to
prior diagnostic or simulation images, and correcting the
patient’s position by controlling the position of the treatment
couch relative to the treatment beam (thus controlling the path of
the radiation source)

PO Resp. 23. Patent Owner concludes that

From these express disclosures of on-line image-guided radiation
therapy on a medical linear accelerator with computer-controlled
image acquisition of CBCTFPI images (Ex. 2080 ¶ 101; Ex.
1210 at 0011) and a translatable treatment couch for positioning
the patient based on the images, a POSA would have recognized
that the ’502 patent inventors were in possession of the limitation
of controlling the path of the radiation source based on 3-D
CBCT-FPI image information, which would have involved
imaging the patient at the time of treatment, comparing the
images to prior diagnostic or simulation images, and
repositioning the patient based on the images. (*Id.* ¶¶ 59-60, 124).

Id. at 27.

We find that Patent Owner has produced sufficient evidence to have met its burden of production, and the burdens¹² concerning this issue are on Petitioner. Petitioner replies that the '590 Application's disclosure of "image-guided radiation therapy" and "navigational imaging for therapies" do not support the disputed limitations—"where controlling is 'based on' the image" (Pet. Reply 8)—because "even if the provisional is considered to inherently disclose control of patient position by couch movements, this is an entirely different class of control step from controlling source path" (*id.* at 8–9).

Having considered the arguments and evidence, we agree with Patent Owner that the '590 Application provides sufficient written description support for "controlling [said path of / a radiation therapy treatment plan involving] said radiation source based on said image." In particular, we credit the testimony of Dr. Hashemi that a person of ordinary skill in the art would have understood from the '590 Application that components of the disclosed system were computer-controlled based upon, e.g., the depiction of an Elekta SL-20 in Figure 3 of the '590 Application and from the depiction of an electronic portal imaging device. (Ex. 2080 ¶¶ 109–116, 125–132).

Petitioner's arguments are not persuasive because, even assuming that controlling the source path and controlling a radiation therapy treatment plan are "an entirely different class of control step" from controlling patient position (Pet. Reply 8–9), Petitioner has not explained *why* the portions of the '590 Application relied upon by Patent Owner do not disclose controlling the source path or controlling a radiation therapy treatment plan.

¹² Both the burden of production and the burden of persuasion.

To the extent that Petitioner is arguing that the '590 Application does not teach control exclusively by the computer without human intervention, that argument is not persuasive because we have construed the limitations to encompass a person or user operating the computer to perform the recited control functions. In post-hearing briefing, both parties agree that this is the proper construction. Papers 77, 78. As a result, even if we assume that a person of ordinary skill in the art reading the '590 Application would have understood “image-guided radiation therapy” (Ex. 1210, 6:14–15), “guiding radiation therapy on a medical linear accelerator” (*id.* at 31:6–7), “on-line imaging and guidance” (*id.* at 1:19), “on-line tomographic guidance” (*id.* at 2:18–19), and “navigational imaging for therapies” (*id.* at 30:5–6) to encompass human involvement, that would not show a lack of support for the disputed limitation, because the disputed limitation does not exclude human intervention.

Accordingly, we determine that Petitioner has not shown sufficiently, on this record, that both Jaffray 1999 SPIE and Jaffray 1999 JRO are prior art to independent claims 43 and 60, and the challenged claims that depend therefrom, under 35 U.S.C. § 102(b).

4. *Whether Jaffray 1999 SPIE and Jaffray 1999 JRO are Prior Art to claims 43–46, 48–55, 57, 59–66 and 68 under 35 U.S.C. § 102(a)*

Again applying the framework from *Dynamic Drinkware*, we determine that Petitioner has met its initial burden of production by asserting that each of Jaffray 1999 SPIE and Jaffray 1999 JRO are prior art under 35 U.S.C. § 102(a). Pet. 18 (“at a minimum, the Jaffray 1999 references are prior art under § 102(a) (pre-AIA) because each published before February 18, 2000, the filing date of the earliest application appearing on the

face of the '502 Patent"). Specifically, Jaffray 1999 SPIE lists a co-author, "D.G. Drake" (Ex. 1205, 016) who is not a named inventor of the '502 patent, and Jaffray 1999 JRO lists three co-authors, Douglas G. Drake, Michel Moreau, and Alvaro A. Martinez (Ex. 1206, 003), who are not named inventors of the '502 patent.

The burden of production having shifted to Patent Owner, Patent Owner asserts that Jaffray 1999 SPIE and Jaffray 1999 JRO are not prior art under 35 U.S.C. § 102(a), because the portions on which Petitioner relies are not the work "of others." PO Resp. 28–39. Specifically, Patent Owner asserts that "Drs. Jaffray and Wong were the sole inventors of the subject matter of the claims challenged in this proceeding, other than claims 51 and 60 of which Drs. Jaffray, Wong, and Siewerdsen were the sole inventors." PO Resp. 31. According to Patent Owner, "Drs. Wong and Jaffray conceived of a flat-panel imager incorporated into a linear accelerator to be used for image-guided radiation therapy as disclosed in these purported references long before the 1999 articles were published." *Id.* at 33 (citing Ex. 2077 ("Jaffray Decl.") ¶¶ 1–9; Ex. 2078 ("Drake Decl.") ¶¶ 1–11).

With respect to the non-inventor co-authors of Jaffray 1999 JRO, Patent Owner contends that Mr. Drake and Mr. Moreau acted solely as technicians, and that Dr. Martinez's support was neither technical nor inventive:

[T]hose co-authors made specific and limited contributions. (Exs. 2077, 2078; Ex. 2080 ¶ 129). Moreau and Drake were technicians following the instructions of the inventors, Jaffray and Wong. And Martinez contributed as the head of the oncology department by supporting Jaffray and Wong's research. None were inventors of the disclosed subject matter at issue in this case.

Mr. Drake was a graduate student in Dr. Jaffray's research group. (Ex. 2078 ¶¶ 2-3). His contribution to the JRO article consisted of capturing images, taking measurements, and assisting with the mechanical construction of the apparatus described in the article. (*Id.* ¶ 5; Ex. 2077 ¶ 7). By Mr. Drake's own admission, his work was entirely at the direction of Drs. Jaffray and Wong. (Ex. 2078 ¶ 5).

Dr. Moreau was a post-doctoral research assistant in Dr. Wong's research group at the time of the work described in the JRO article. (Ex. 2078 ¶ 9; Ex. 2077 ¶ 8). He was involved in mechanical characterization, such as flex of the gantry, of the linear accelerator-mounted cone-beam CT imaging system shown in the JRO article. (*Id.*). All of his work was done under the direction of Drs. Jaffray and Wong. (Ex. 2078 ¶¶ 9, 11; Ex. 2077 ¶ 8).

Dr. Martinez was the head of the department of radiology at Beaumont hospital at the time. (Ex. 2078 ¶ 10; Ex. 2077 ¶ 9). In this role, Dr. Martinez supervised Jaffray and Wong's use of department facilities and permitted them to make experimental modifications to a clinical treatment apparatus—the Elekta SL-20 described in the article. (*Id.*). While his support was valuable enough to warrant inclusion as a co-author, the modifications to the Elekta SL-20 were done at the direction of Jaffray and Wong. (Ex. 2078 ¶ 11; Ex. 2077 ¶¶ 2, 9).

Id. at 34–35. Patent Owner concludes that, “[t]his evidence shows that none of the co-authors besides Jaffray and Wong contributed to inventing the subject matter from the JRO article on which Petitioner now relies.” *Id.* at 35.

With respect to the relevant subject matter in Jaffray 1999 SPIE, Patent Owner contends that it was conceived by Drs. Jaffray and Wong “and, in one instance, the contribution of Dr. Siewerdsen to the joint invention of claims 51 and 61” (PO Resp. 36) and that “[t]his contribution by Dr. Siewerdsen was the only inventive contribution by either him or Mr.

Drake—the co-authors listed on the SPIE article with Dr. Jaffray—to the subject matter Petitioner relies on in this case against the challenged claims” (*id.* at 38–39). *See also id.* at 37–39 (describing Siewerdsen’s and Drake’s contributions).

In light of Patent Owner’s arguments and evidence, we determine that Patent Owner has met its burden of production, and the burdens¹³ concerning this issue shift back to Petitioner.¹⁴ Petitioner replies that (1) the inventors failed to swear-behind the Jaffray 1999 Articles because the Declarations of Dr. Jaffray and Mr. Drake do not establish conception and reduction to practice (Reply 10–14); (2) the testimony of Dr. Jaffray and Mr. Drake is biased and uncorroborated (*id.* at 14–19); and (3) the testimony “leave[s] unresolved questions regarding the inventive entity of Jaffray 1999 SPIE” (*id.* at 19–20).

Having considered the parties arguments and evidence regarding “[t]he content and nature of the printed publication, as well as the circumstances surrounding its publication” (*Katz*, 687 F.2d at 455), we are not persuaded that Petitioner has met its burden of persuasion by showing sufficiently that the portions of Jaffray 1999 SPIE and Jaffray 1999 JRO on which it relies are the work “others.” Unlike in *Katz*, where the question was “the sufficiency of applicant’s showing to establish that the subject disclosure was his original work, and his alone” (687 F.2d at 455), the question before us is the sufficiency of Petitioner’s showing to establish that the subject disclosure was the work of the non-inventor coauthors of Jaffray

¹³ Both the burden of production and the burden of persuasion.

¹⁴ At oral argument, counsel for Petitioner indicated that, in his view, it does not matter who has the burden. Tr. 20:9, 20:16–17.

1999 SPIE and Jaffray 1999 JRO. *See Dynamic Drinkware*, 800 F.3d at 1378 (“In an *inter partes* review, the burden of persuasion is on the petitioner to prove ‘unpatentability by a preponderance of the evidence,’ 35 U.S.C. § 316(e), and that burden never shifts to the patentee.”); *In re Magnum Oil Tools Int’l, Ltd.*, 829 F.3d 1364, 1373 (Fed. Cir. 2016) (“In the context of the present case, however, the notion of burden-shifting is inapposite because the patentee’s position is that the patent challenger failed to meet *its* burden of proving obviousness.”); *see also Duncan Parking Techs., Inc. v. IPS Group Inc.*, Case IPR2016-00067, slip op. at 8–13 (PTAB Mar. 27, 2017) (Paper 29).

Patent Owner presents testimony of Dr. Jaffray and Mr. Drake that the subject matter relied upon by Petitioner was not the work of the non-inventor coauthors, and after considering all relevant arguments and evidence, we are unpersuaded by Petitioner’s assertions that this testimony is unreliable. Dr. Jaffray testifies, for example, that “[t]he JRO article and the SPIE article disclose work done at the direction of me and Dr. Wong in support of the joint research conducted by the two of us.” Ex. 2077 ¶ 2. Dr. Jaffray further testifies that “with the exception of Dr. Siewerdsen coming up with the pre-reconstruction image processing for the SPIE article, the [non-inventor] co-authors did not come up with the ideas for the systems described in those articles.” *Id.* ¶ 6. Dr. Jaffray describes the contributions of the co-authors as follows:

7. Douglas Drake was a graduate student in the physics program at Oakland University. I was his graduate advisor. At my direction, he collected images, took measurements, and performed calculations that were used in the SPIE and JRO articles.

8. Michel Moreau was a post-doctoral student working in Dr. Wong's research group. Acting under instruction from me and Dr. Wong, Dr. Moreau characterized the flex of the gantry and x-ray detectors used in the radiographic studies as described in the JRO article. (Ex. 1006 at 779.)

9. Dr. Alvaro Martinez was the head of the Department of Radiation Oncology at William Beaumont Hospital. Dr. Martinez was very interested in using radiation therapy for treatment of prostate cancer, and Dr. Wong and I used treatment of carcinomas of the prostate as an initial use-case for our conceived online cone-beam image-guided radiotherapy system. As the department head, Dr. Martinez's support was instrumental in obtaining resources from the hospital for our research. In one notable and relevant example of this support, Dr. Martinez allowed our research group to modify the Elekta SL-20 pictured in Figure 1 of the JRO article. That linear accelerator was in operation for clinical treatment of patients at the time. Despite this and despite the fact that the SL-20 was an expensive piece of therapeutic medical equipment, Dr. Martinez allowed us to drill holes in it, add components to it, and use it for our research outside of normal business hours. The support of Dr. Martinez and, through him, of William Beaumont Hospital was crucial to the research described in the JRO article.

Ex. 2077 ¶¶ 7-9. This testimony is corroborated by Mr. Drake, who testifies that

5. My role in the work described in the JRO article was to collect data and take measurements. For example, I would capture images using the imaging system mounted on the SL-20 linear accelerator that is described in the JRO article. Because the linear accelerator was still in use as a clinical machine, we needed to wait until after business hours to start capturing images. I also performed analysis of the collected images, such as signal-to-noise ratio, contrast, resolutions and other characteristics of image quality. I also assisted with modifications to the linear accelerator. All this work was done at the direction of Dr. Jaffray and Dr. Wong.

6. My role in the work described in the SPIE article was similar. I collected some images and performed image quality analysis, such as signal-to-noise ratio, resolution and contrast, for the images collected by me or Dr. Jeff Siewerdsen. Again, similar to the JRO article, I assisted with construction of the experimental set-up described in the article and prepared AutoCAD drawings for the Beaumont machinist who machined the parts used in the set-up. Again all this work was done at the direction of Dr. Jaffray and Dr. Wong.

Ex. 2078 ¶¶ 5–6. With respect to the other co-authors, Mr. Drake testifies that

7. I am also familiar with the work done on the project by the other coauthors of the SPIE article and the JRO article.

8. Dr. Siewerdsen was a co-author of the SPIE article. Dr. Siewerdsen joined the Radiation Oncology department at Beaumont Hospital in the summer of 1998 after Drs. Wong and Jaffray had begun to work to develop a cone beam CT/flat-panel imager system for use on a linear accelerator. Dr. Siewerdsen and I both helped Dr. Jaffray build the bench-top system depicted in Figure 1(a) of the SPIE article. Dr. Siewerdsen also used the system to capture images, and I assisted with analysis of those image-quality measurements. Dr. Siewerdsen was involved in the decision to use certain image processing techniques before reconstructing the volumetric CT data set, as described in the SPIE article. (*See Ex. 1005 at 207.*)

9. Dr. Michel Moreau was a co-author of the JRO article. Dr. Moreau was a post-doctoral student researcher in the group working under Dr. Wong's direction. He was involved in mechanical characterization of the linear accelerator-mounted cone beam CT imaging system shown in the JRO article.

10. Dr. Alvaro Martinez was a co-author of the JRO article. Dr. Martinez had management responsibility for the department and supervised the use of its facilities. The SL-20 linear accelerator that was modified as shown in the JRO article was the hospital's clinical machine. He allowed the team to modify the machine and to do our tests on it, even though it was

an expensive piece of equipment that the hospital was actively using for treating patients.

Ex. 2078 ¶¶ 7–10.

Petitioner’s argument that the testimony of Dr. Jaffray and Mr. Drake is insufficient to antedate Jaffray 1999 SPIE and Jaffray 1999 JRO, because it does not establish conception and reduction to practice before February 1999, is unpersuasive because it imposes an unnecessary requirement on Patent Owner. The cases relied upon by Petitioner—*Perfect Surgical Techniques, Inc. v. Olympus Am., Inc.*, 841 F.3d 1004 (Fed. Cir. 2016); *In re NTP, Inc.*, 654 F.3d 1279 (Fed. Cir. 2011); *Sandt Tech., Ltd. v. Resco Metal & Plastics Corp.*, 264 F.3d 1344 (Fed. Cir. 2001); *NHK Seating of Am., Inc. v. Lear Corp.*, No. IPR2014-01200, 2016 WL 416547, at *6-7 (P.T.A.B. Feb. 2, 2016)—are inapposite because they do not address the question of whether a work is by “others” for purposes of § 102(a). For that determination, “[w]hat is required is a reasonable showing supporting the basis for [Patent Owner]’s position.” *In re Katz*, 687 F.2d at 455. In *Katz*, the Federal Circuit found sufficient an inventor’s testimony that he was the sole inventor, and that the co-authors of the publication were merely working under his direction:

In this case, appellant averred in his declaration that he is the sole inventor of the subject matter described and claimed in his application and also that disclosed in the publication of proceedings of the National Academy of Science. We do not view this averment as a mere pro forma restatement of the oath in his application.

In the declaration, appellant provides the explanation that the co-authors of the publication, Chiorazzi and Eshhar, “were students working under the direction and supervision of the inventor, Dr. David H. Katz.” This statement is of significance since it provides a clear alternative conclusion to the board’s inference

that their names were on the article because they were coinventors. As acknowledged by the examiner, the names of individuals may be given as authors of a scientific report who are “involved only with assay and testing features of the invention.” Appellant’s explanation is, thus, consistent not only with the content of the article but with the nature of the publication. On the record here, the board should not have engaged in further speculation as to whether appellant’s view was shared by his co-authors but rather should have accepted that Chiorazzi and Eshhar were acting in the capacity indicated, that is, students working under the direction and supervision of appellant. From such a relationship, joint inventorship cannot be inferred in the face of sworn statements to the contrary.

Id. at 455–456. Petitioner does not explain persuasively why we should not rely on a declaration by a named inventor, as the Federal Circuit did in *Katz*, and why we should instead apply case law relating to prior art authored solely by non-inventors.

We also are unpersuaded by Petitioner’s argument that “the [Jaffray and Drake] declarations are devoid of corroborative support and the allegations made within them cannot be credited because of profound bias and foundation concerns.” Reply 16 (citing *Ex Parte Kroger*, 219 U.S.P.Q. 370 (Bd. Pat. App. & Int. 1982)). Petitioner argues that “there remain four individuals— Wong, Siewerdsen, Moreau, and Martinez—whose views on inventorship are unknown,” and that “it should be Patent Owner’s burden to” obtain testimony from those individuals. *Id.* at 16–17. *Ex Parte Kroger*, however, does not stand for the proposition that declarations from only a subset of named inventors is *per se* insufficient to satisfy *Katz*. Indeed, the issue in *Ex Parte Kroger* was that a co-author of the publication being relied upon as prior art refused to agree that he was not a co-inventor:

However, this case distinguishes from *In re Katz* in that Knaster has refused to sign a declaration submitted to him by the attorneys for the present applicants, which declaration is to the effect that Knaster is not a coinventor. Also, Knaster has introduced evidence into the case in the form of a letter to the Patent and Trademark Office in which he declares himself to be a coinventor with the present applicants.

Ex Parte Kroger, 219 U.S.P.Q. at 372. Here, we have no such evidence. Petitioner has not, for example, submitted declarations of, or otherwise elicited testimony from, any of Mr. Drake, Dr. Moreau, Dr. Siewerdsen, Dr. Wong, or Dr. Martinez to the effect that they cast sufficient doubt on Patent Owner's representations concerning the proper co-inventors of the subject matter claimed in the '502 patent, or the proper attributions of the subject matter of Jaffray 1999 SPIE and Jaffray 1999 JRO.¹⁵ Notwithstanding Petitioner's contention that it should be Patent Owner's burden to obtain testimony from these individuals, the burden of persuasion is ultimately on Petitioner. Petitioner's attacks on the testimony relied upon by Patent Owner are insufficient for the reasons set forth above, and Petitioner has not provided any affirmative evidence that Jaffray 1999 SPIE and Jaffray 1999 JRO are works by "others."

Also unpersuasive is Petitioner's argument that "[t]he declarations entirely lack corroborative support" because "documents exist from the

¹⁵ We denied Petitioner's request for additional discovery to compel the depositions of Dr. Moreau, Dr. Siewerdsen, Dr. Wong, and Dr. Martinez because Petitioner's evidence did not amount to more than mere speculation or allegation that something useful would be found. Paper 37. That Petitioner did not meet its burden in its request for additional discovery, however, does not excuse its failure to meet the appropriate burden on this issue. Moreover, we note that Petitioner had the opportunity to explore these issues at the depositions of Dr. Jaffray and Mr. Drake.

relevant time period, but Patent Owner failed to cite even a single corroborative document as evidence.” Pet. Reply 17. Dr. Jaffray’s testimony is corroborated by the testimony of Mr. Drake. For example, Dr. Jaffray’s testimony that Mr. Moreau “characterized the flex of the gantry and x-ray detectors” (Ex. 2077 ¶ 8) is corroborated by Mr. Drake’s testimony that Mr. Moreau “was involved in mechanical characterization of the linear accelerator-mounted cone beam CT imaging system” (Ex. 2078 ¶ 9). The same is true for Dr. Jaffray’s testimony regarding the contributions of himself and Dr. Wong, and the contributions of Mr. Drake and Dr. Alvaro Martinez.

Petitioner argues that Dr. Jaffray’s testimony is biased due to a “clear conflict of interest in wishing to see the validity of the patents preserved irreparably taints his testimony,” and should be afforded no weight. Pet. Reply 18. A financial interest is certainly a factor in deciding how much weight to give Dr. Jaffray’s testimony, but much of his testimony is corroborated by Mr. Drake, who Petitioner does not allege to have a financial interest. Petitioner argues that Mr. Drake’s testimony lacks foundation because “he never even reviewed the Jaffray JRO 1999 article” before providing statements about that article in paragraphs 4 and 5 of his Declaration, and he “failed to discuss his allegations with any of the other individuals involved.” *Id.* The statement in paragraph 4, however, is very general. Ex. 2078 ¶ 4 (“Both the JRO article and the SPIE article describe work done to establish the feasibility of such a system. The JRO article describes work done to establish that cone beam CT would work when installed on a linear accelerator for on-line image guided radiation therapy.”). The statement in paragraph 5 is about his role in the work

described in the JRO article. *Id.* ¶ 5 (“My role in the work described in the JRO article was to collect data and take measurements”). Given the nature of this testimony as either very general or as focused on his role, we are not persuaded that either reviewing Jaffray 1999 JRO or discussing his testimony with other potential fact witnesses was necessary in order for Mr. Drake to have a sufficient foundation for his testimony.

Finally, we are unpersuaded by Petitioner’s argument that the Declarations “leave unresolved questions regarding the inventive entity of Jaffray 1999 SPIE.” Pet. Reply 19. Specifically, Petitioner suggests that Dr. Wong’s omission as a co-author of Jaffray 1999 SPIE is significant. *Id.* (“Absent any explanation for Wong’s omission, it is unreasonable to conclude that Jaffray and Wong were the inventors of the subject matter of Jaffray 1999 SPIE.”). Unlike the inclusion of a non-inventor co-author on a publication, however, the omission of a named inventor from co-authorship has no significance for whether the publication is the work of “others.” If, for example, Dr. Wong was erroneously omitted as a co-author of Jaffray 1999 SPIE, that would not establish that the portions of Jaffray 1999 SPIE relied upon by Petitioner are the work of someone other than Dr. Jaffray, Dr. Wong, or Dr. Siewerdsen—i.e., the named inventors of the ’502 patent. Furthermore, despite Petitioner’s innuendo about the significance of Dr. Wong’s omission, Petitioner did not bother to ask Dr. Jaffray about this very issue at his deposition. Moreover, Petitioner has not put forth any affirmative evidence to suggest that the work described in Jaffray 1999 SPIE was the work of someone other than Dr. Jaffray, Dr. Wong, or Dr. Siewerdsen.

Accordingly, we determine that Petitioner has not met its burden of showing sufficiently that both Jaffray 1999 SPIE and Jaffray 1999 JRO are prior art to independent claims 43 and 60, and the challenged claims that depend therefrom, under 35 U.S.C. § 102(a).

C. The Challenged Claims -- Obviousness based on Jaffray 1999 SPIE and Jaffray 1999 JRO

Petitioner asserts that a combination of Jaffray 1999 SPIE, Jaffray 1999 JRO, Adler, and Depp renders obvious claims 43–46, 48–55, 57, and 59 (Pet. 17–46 (citing Exs. 1202–1206)), and that a combination of Jaffray 1999 SPIE, Jaffray 1999 JRO, Adler, Depp, and Yan renders obvious claims 60–66 and 68 (Pet. 17–49 (citing Exs. 1202–1207)). Petitioner relies solely upon Jaffray 1999 SPIE and Jaffray 1999 JRO for several limitations of independent claims 43 and 60, including, for example, “emitting an x-ray beam in a cone beam form towards an object,” recited in each claim. Pet. 27–28, 47–48. As discussed above, however, we not persuaded that Jaffray 1999 SPIE and Jaffray 1999 JRO are prior art to claims 43–46, 48–55, 57, 69–66, and 68. Moreover, Petitioner does not contend that Adler, Depp, or Yan teach these limitations. As a result, we are not persuaded that Petitioner has met its burden of showing, by a preponderance of the evidence, that claims 43–46, 48–55, 57, and 59 are obvious over a combination of Jaffray 1999 SPIE, Jaffray 1999 JRO, Adler, and Depp, and that claims 60–66 and 68 are obvious over a combination of Jaffray 1999 SPIE, Jaffray 1999 JRO, Adler, Depp, and Yan.

D. Patent Owner’s Motion to Exclude

Patent Owner requests that “Exhibits 1214–1217 and 1219–1237 (‘Exhibits’) and Paragraphs 104–130 and 132–138 of Exhibit 1202 (‘Balter

Testimony’) be excluded and expunged from the record” because they are “irrelevant to the ground on which this proceeding was instituted” and “the exhibits have not been cited by either Party.” PO Mot. 1. Petitioner responds that the aforementioned Exhibits were cited, albeit in a cursory manner, at page 4 of the Petition (Pet. Opp. 1), and that the Board has, effectively, already excluded the referenced Exhibits and testimony as follows:

This interpretation is also consistent with the Board’s determination in its Institution Decision that the exhibits in question should not be relied upon to “‘fill in’ any ‘gap’ in the Petition.” (*See* Paper 14 at 22.) Thus, in this case Patent Owner already obtained adequate relief for its concerns regarding the supposedly “extraneous” Exhibits and Balter Testimony by virtue of the Institution Decision. As Patent Owner acknowledged in its motion, Petitioner complied with the Board’s directive did not rely on this evidence in its Reply papers. (*See* Paper 59 at 2.)

Pet. Opp. 2. Patent Owner replies that retaining the Exhibits and testimony leaves open the possibility that Petitioner may attempt to rely on them during appeal. PO Reply 2–3.

Patent Owner’s Motion is *denied*. Petitioner does refer to the referenced Exhibits, however briefly, in the Petition, and so retaining the papers would assist the public in better understanding, however minimally, the record. Furthermore, this Decision does not rely on portions of those Exhibits or testimony, and we determine expressly that it is improper for Petitioner to rely on those Exhibits and testimony, because, other than the cursory mention, their relevance was not explained adequately with respect to any ground of unpatentability in the Petition. Additionally, that Petitioner may use such Exhibits and testimony on appeal is speculative. Furthermore,

we are unpersuaded that there is sufficient prejudice to Patent Owner in denying their request, as we are unclear how any of those Exhibits is relevant to our determination that neither Jaffray 1999 SPIE nor Jaffray 1999 JRO are prior art under either § 102(a) or § 102(b). Accordingly, Patent Owner's Motion to Exclude is *denied*.

E. Petitioner's Allegedly Improper New Arguments and Evidence in Reply

We have considered Patent Owner's listing (Paper 60) and Petitioner's responsive listing (Paper 68) on this issue. Patent Owner's assertions are moot, because, even considering those portions of the Reply and Dr. Balter's Supplemental Declaration, Petitioner has still not met its burden.

F. Papers Under Seal

This Final Written Decision discusses or cites information in papers that are subject to a Protective Order. For those papers, the Parties should follow the guidance related to 37 C.F.R. § 42.56. *See* Office Patent Trial Practice Guide, 77 Fed. Reg. 48,756, 48,761 (Aug. 14, 2012)

III. CONCLUSION

Petitioner has not shown, by a preponderance of the evidence, that claims 43–46, 48–55, 57, 59–66, and 68 are unpatentable. Patent Owner's Motion to Exclude is *denied*.

IV. ORDER

After due consideration of the record before us, and for the foregoing reasons, it is:

IPR2016-00163
Patent 6,842,502 B2

ORDERED claims 43–46, 48–55, 57, 59–66, and 68 of the '502 Patent are not held unpatentable; and

FURTHER ORDERED that Patent Owner's Motion to Exclude is *denied*; and

FURTHER ORDERED that because this is a final written decision, parties to the proceeding seeking judicial review of the decision must comply with the notice and service requirements of 37 C.F.R. § 90.2.

IPR2016-00163
Patent 6,842,502 B2

PETITIONER:

Heidi L. Keefe
Daniel J. Knauss
Scott A. Cole
Adam Pivovar
Reuben Chen
Stephen Smith
COOLEY LLP
hkeefe@cooley.com
dknauss@cooley.com
apivovar@cooley.com
rchen@cooley.com
Stephen.smith@cooley.com
Varian_PTAB_IPR@cooley.com

PATENT OWNER:

Theresa M. Gillis
Amanda K. Streff
B. Clayton McCraw
Kyle E. Friesen
MAYER BROWN LLP
TGillis@mayerbrown.com
AStreff@mayerbrown.com
CMcCraw@mayerbrown.com
kfriensen@mayerbrown.com

Gregory A. Morris
Jonathan P. O'Brien, Ph.D.
J. Michael Huget
HONIGMAN MILLER SCHWARTZ AND COHN LLP
gmorris@honigman.com
jobrien@honigman.com
mhuget@honigman.com