

UNITED STATES PATENT AND TRADEMARK OFFICE

BEFORE THE PATENT TRIAL AND APPEAL BOARD

ST. JUDE MEDICAL, LLC,
Petitioner,

v.

SNYDERS HEART VALVE LLC,
Patent Owner.

Case IPR2018-00106
Patent 6,540,782 B1

Before PATRICK R. SCANLON, MITCHELL G. WEATHERLY, and
JAMES A. WORTH, *Administrative Patent Judges*.¹

SCANLON, *Administrative Patent Judge*.

FINAL WRITTEN DECISION
35 U.S.C. § 318(a) and 37 C.F.R. § 42.73

¹ Director Andrei Iancu has taken no part in this Decision due to recusal.

I. INTRODUCTION

St. Jude Medical, LLC (“Petitioner”) filed a Petition (Paper 3, “Pet.”) requesting an *inter partes* review of claims 1, 2, 4–8, 10–13, 17–19, 21, 22, and 25–30 of U.S. Patent No. 6,540,782 B1 (Ex. 1001, “the ’782 patent”). Snyders Heart Valve LLC (“Patent Owner”) filed a Preliminary Response (Paper 10, “Prelim. Resp.”). The Board instituted a trial as to claims 1, 2, 4–8, 10–13, 17–19, 21, 22, and 25–30 of the ’782 patent. Paper 15 (“Institution Decision,” “Dec.”).

After institution of trial, Patent Owner filed a Patent Owner Response (“PO Resp.”) to the Petition. Paper 30. Petitioner filed a Reply (“Reply”) to the Patent Owner Response. Paper 38. Patent Owner filed a Sur-Reply (“Sur-Reply”). Paper 40. Petitioner relies on the Declaration of Lakshmi Prasad Dasi, Ph.D. (Ex. 1003) in support of its Petition, and Patent Owner relies on the Declaration of Dr. Nicolas Chronos (Ex. 2026) in support of its Response.

Petitioner filed a Motion to Exclude Evidence (Paper 45, “Mot. to Exclude”) and a Motion to Strike (Paper 46, “Mot. To Strike”). Patent Owner filed an Opposition to the Motion to Exclude (Paper 48, “Opp. Mot. to Exclude”) and an Opposition to the Motion to Strike (Paper 49, “Opp. Mot. To Strike”). Petitioner filed a Reply to the Opposition to the Motion to Exclude. Paper 52 (“Mot. to Exclude Reply”).

An oral hearing was held on January 30, 2019, and the record contains a transcript of this hearing. Paper 57 (“Tr.”).

We have jurisdiction under 35 U.S.C. § 6. This Final Written Decision is issued pursuant to 35 U.S.C. § 318(a) and 37 C.F.R. § 42.73.

For the reasons that follow, we determine that Petitioner has shown by a preponderance of the evidence that claims 1, 2, 6, and 8 of the '782 patent are unpatentable, but has not shown by a preponderance of the evidence that claims 4, 5, 7, 10–13, 17–19, 21, 22, and 25–30 of the '782 patent are unpatentable. Petitioner's Motion to Exclude Evidence and Motion to Strike are both dismissed as moot.

II. BACKGROUND

A. Related Matters

The parties indicate that the '782 patent is at issue in *Snyders Heart Valve LLC v. St. Jude Medical SC, Inc.*, No. 4:16-cv-00812 (E.D. Tex.). Pet. 1; Paper 5, 2. Related *inter partes* review proceeding IPR2018-00105 also involves the '782 patent. In addition, U.S. Patent No. 6,821,297 B2, which is related to the '782 patent, is the subject of related *inter partes* review proceedings IPR2018-00107 and IPR2018-00109.

B. The '782 patent

The '782 patent, titled "Artificial Heart Valve," issued April 1, 2003, with claims 1–30. Ex. 1001, (54), (45), 10:22–16:39. The '782 patent is directed to "artificial heart valves for repairing damaged heart valves." *Id.* at 1:11–12. Figures 2 and 3 of the '782 patent are reproduced below.

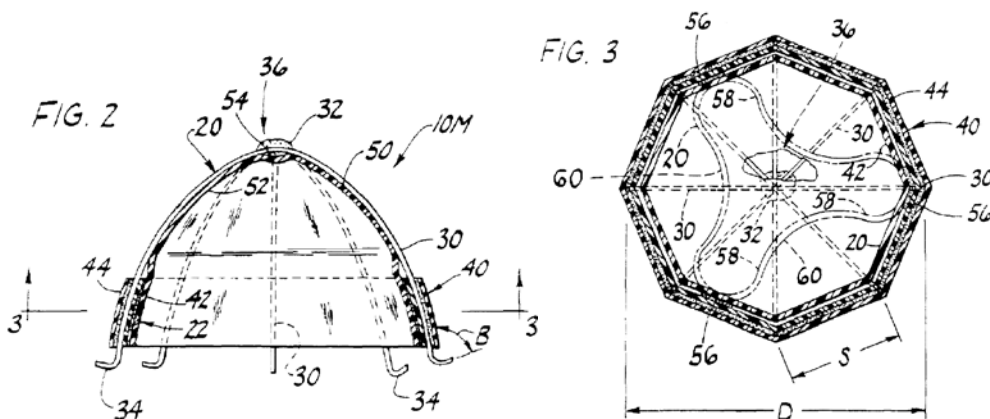

Figure 2 depicts “a vertical cross section of an artificial valve,” and Figure 3 depicts “a cross section of the valve taken in the plane of line 3–3 of FIG. 2.” *Id.* at 4:8–10. Artificial valve 10M shown in Figures 2 and 3 “is specifically configured for repairing a damaged mitral valve,” although the ’782 patent also discloses an artificial valve configured to repair a damaged pulmonary heart valve. *Id.* at 4:30–33.

Artificial valve 10M comprises flexibly resilient external frame 20 and flexible valve element 22. *Id.* at 4:48–50. Frame 20 includes U-shaped stenting elements 30 that are joined together generally midway between their respective ends at junction 32. *Id.* at 4:51–58. U-shaped elements 30 are sufficiently compressible to allow valve 10M to be compressed into a configuration for implantation and sufficiently resilient to hold valve 10M in position between the cusps of a native heart valve after implantation while holding the cusps open. *Id.* at 4:61–5:2. Peripheral anchors 34 are formed at each end of the U-shaped elements to attach frame 20 in position between an upstream region and a downstream region. *Id.* at 5:13–17. Frame 20 further includes central portion 36 located between peripheral anchors 34. *Id.* at 5:26–29.

Artificial valve 10M also comprises band 40 that extends around frame 20 between U-shaped frame elements 30 to limit maximum spacing between the frame elements, but permit the frame elements to be pushed together so flexibly resilient frame 20 can be collapsed to a collapsed configuration. *Id.* at 5:30–37. Band 40 preferably includes internal strip 42 and external strip 44 joined in face-to-face relation. *Id.* at 6:5–7.

Flexible valve element 22 is attached to central portion 36 of frame 20 and has convex upstream side 50 facing an upstream region and concave downstream side 52 facing a downstream region. *Id.* at 6:24–32. With this arrangement, “valve element 22 moves in response to differences between fluid pressure in the upstream region and the downstream region between an open position (as shown in phantom lines in FIG. 3) and a closed position (as shown in solid lines in FIG. 3).” *Id.* at 6:35–39. Flexible valve element 22 permits flow between the upstream and downstream regions when in its open position and blocks flow between the upstream and downstream regions when in its closed position. *Id.* at 6:39–43.

More specifically, apex 54 of upstream side 50 is attached to junction 32 of frame 20. *Id.* at 7:1–3. As shown in Figure 3, flexible valve element 22 also is attached to band 40 at several attachment points 56, such that flexible valve element 22 defines flaps 58 between adjacent attachment points. *Id.* at 7:10–14. Flaps 58 and corresponding portions of band 40 define openings 60 when valve element 22 moves to its open position. *Id.* at 7:14–17.

Figure 4 of the '782 patent is reproduced below.

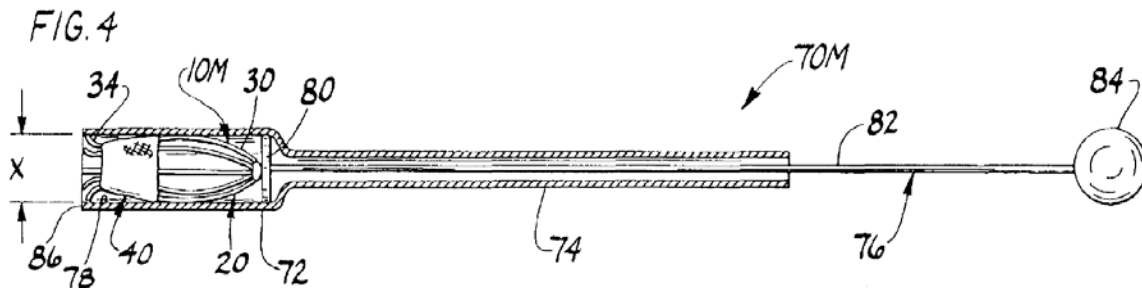

Figure 4 depicts “a vertical cross section of an instrument for implanting a valve using an endothoracoscopic procedure.” *Id.* at 4:11–13. The instrument of Figure 4 includes tubular holder 72 and elongate tubular

manipulator 74 attached to the holder for manipulating the holder into position. *Id.* at 7:34–36. The instrument further includes ejector 76 that is positioned in the hollow interior of holder 72 for ejecting an artificial heart valve from the holder. *Id.* at 7:36–39.

C. Challenged Claims

As noted above, Petitioner challenges claims 1, 2, 4–8, 10–13, 17–19, 21, 22, and 25–30 of the '782 patent. Claims 1, 10, 17, 18, 28, 29, and 30 are independent. Claims 2 and 4–8 depend, directly or indirectly, from independent claim 1, and claims 19, 21, 22, and 25–27 depend, directly or indirectly, from independent claim 18. Independent claim 1 is reproduced below:

1. An artificial valve for repairing a damaged heart valve having a plurality of cusps separating an upstream region from a downstream region, said artificial valve comprising:

a flexibly resilient frame sized and shaped for insertion in a position between the upstream region and the downstream region, the frame having a plurality of peripheral anchors for anchoring the frame in the position between the upstream region and the downstream region and a central portion located between the plurality of peripheral anchors;

a band attached to the frame limiting spacing between adjacent anchors of said plurality of peripheral anchors; and

a flexible valve element attached to the central portion of the frame and adjacent the band, said valve element being substantially free of connections to the frame except at the central portion of the frame and adjacent the band, said valve element having an upstream side facing said upstream region when the frame is anchored in the position between the upstream region and the downstream region and a downstream side opposite the upstream side facing said downstream region when the frame is anchored in the position between the upstream region and the

downstream region, said valve element moving in response to a difference between fluid pressure in said upstream region and fluid pressure in said downstream region between an open position in which the element permits downstream flow between said upstream region and said downstream region and a closed position in which the element blocks flow reversal from said downstream region to said upstream region, wherein the valve element moves to the open position when fluid pressure in said upstream region is greater than fluid pressure in said downstream region to permit downstream flow from said upstream region to said downstream region and the valve element moves to the closed position when fluid pressure in said downstream region is greater than fluid pressure in said upstream region to prevent flow reversal from said downstream region to said upstream region.

Ex. 1001, 10:22–60.

D. The Prior Art

Petitioner's asserted grounds of unpatentability for the challenged claims rely on the following references:

Andersen	US 5,411,552	May 2, 1995	Ex. 1006
Bessler	US 5,855,601	Jan. 5, 1999	Ex. 1008
Imachi	US 5,413,599	May 9, 1995	Ex. 1020
Johnson	US 4,339,831	July 20, 1982	Ex. 1021

E. Grounds of Unpatentability at Issue

The Petition challenges claims 1, 2, 4–8, 10–13, 17–19, 21, 22, and 25–30 of the '782 patent on the following four grounds of unpatentability. Pet. 3. We instituted trial on all four grounds, and for all claims subject to each asserted ground. Dec. 2, 23.

Reference(s)	Basis	Claims Challenged
Bessler	§ 102	1, 2, 4–8, 10–13, 17–19, 21, 22, and 25–30
Bessler and Andersen	§ 103	1, 2, 4–8, 10–13, 17–19, 21, 22, and 25–30
Johnson, Bessler, and Imachi	§ 103	1, 2, 4–8, 10–13, 17–19, 21, 22, and 25–30
Bessler, Johnson, and Imachi	§ 103	1, 2, 4–8, 10–13, 17–19, 21, 22, and 25–30

III. ANALYSIS

A. Relevant Legal Principles

To prevail in challenging Patent Owner’s claims, Petitioner must demonstrate by a preponderance of the evidence that the claims are unpatentable. 35 U.S.C. § 316(e); 37 C.F.R. § 42.1(d). “In an [*inter partes* review], the petitioner has the burden from the onset to show with particularity why the patent it challenges is unpatentable.” *Harmonic Inc. v. Avid Tech., Inc.*, 815 F.3d 1356, 1363 (Fed. Cir. 2016) (citing 35 U.S.C. § 312(a)(3) (requiring *inter partes* review petitions to identify “with particularity . . . the evidence that supports the grounds for the challenge to each claim”)). The burden of persuasion rests with Petitioner. *See Dynamic Drinkware, LLC v. Nat’l Graphics, Inc.*, 800 F.3d 1375, 1378 (Fed. Cir. 2015) (citing *Tech. Licensing Corp. v. Videotek, Inc.*, 545 F.3d 1316, 1326–27 (Fed. Cir. 2008)) (discussing the burden of proof in *inter partes* review). Furthermore, Petitioner cannot satisfy its burden of proving obviousness by employing “mere conclusory statements.” *In re Magnum Oil Tools Int’l, Ltd.*, 829 F.3d 1364, 1380 (Fed. Cir. 2016).

“A claim is anticipated only if each and every element as set forth in the claim is found, either expressly or inherently described, in a single prior art reference.” *Verdegaal Bros. Inc., v. Union Oil Co.*, 814 F.2d 628, 631 (Fed. Cir. 1987). Moreover, “[b]ecause the hallmark of anticipation is prior invention, the prior art reference—in order to anticipate under 35 U.S.C. § 102—must not only disclose all elements of the claim within the four corners of the document, but must also disclose those elements ‘arranged as in the claim.’” *Net MoneyIN, Inc. v. VeriSign, Inc.*, 545 F.3d 1359, 1369 (Fed. Cir. 2008). Whether a reference anticipates is assessed from the perspective of an ordinarily skilled artisan. *See Dayco Prods., Inc. v. Total Containment, Inc.*, 329 F.3d 1358, 1368 (Fed. Cir. 2003) (“[T]he dispositive question regarding anticipation [i]s whether *one skilled in the art* would reasonably understand or infer from the [prior art reference’s] teaching that every claim element was disclosed in that single reference.”).

A claim is unpatentable under 35 U.S.C. § 103(a) if the differences between the claimed subject matter and the prior art are such that the subject matter, as a whole, would have been obvious at the time the invention was made to a person having ordinary skill in the art to which said subject matter pertains. *KSR Int’l Co. v. Teleflex Inc.*, 550 U.S. 398, 406 (2007). The question of obviousness is resolved on the basis of underlying factual determinations including (1) the scope and content of the prior art; (2) any differences between the claimed subject matter and the prior art; (3) the level of skill in the art; and, (4) where in evidence, so-called secondary considerations, including commercial success, long-felt but unsolved needs,

failure of others, and unexpected results. *Graham v. John Deere Co.*, 383 U.S. 1, 17–18 (1966).

For an obviousness analysis, prior art references must be “considered together with the knowledge of one of ordinary skill in the pertinent art.” *In re Paulsen*, 30 F.3d 1475, 1480 (Fed. Cir. 1994) (quoting *In re Samour*, 571 F.2d 559, 562 (CCPA 1978)). Moreover, “it is proper to take into account not only specific teachings of the reference but also the inferences which one skilled in the art would reasonably be expected to draw therefrom.” *In re Preda*, 401 F.2d 825, 826 (CCPA 1968). That is because an obviousness analysis “need not seek out precise teachings directed to the specific subject matter of the challenged claim, for a court can take account of the inferences and creative steps that a person of ordinary skill in the art would employ.” *KSR*, 550 U.S. at 418.

B. Level of Ordinary Skill in the Art

Petitioner contends that a person having ordinary skill in the art to which the '782 patent pertains “is a medical doctor or has an advanced degree (at least a master’s degree) in a relevant engineering discipline with several years of experience or someone who holds a lesser degree with more experience in the field of artificial heart valves.” Pet. 13–14 (citing Ex. 1001; Ex. 1006; Ex. 1008; Ex. 1009; Ex. 1010; Ex. 1020; Ex. 1003, ¶¶ 15–17). Patent Owner does not dispute this contention in its Preliminary Response, Response, or Sur-Reply, nor does Patent Owner offer its own definition of the level of ordinary skill in the art.

Factual indicators of the level of ordinary skill in the art include “the various prior art approaches employed, the types of problems encountered in the art, the rapidity with which innovations are made, the sophistication of

the technology involved, and the educational background of those actively working in the field.” *Jacobson Bros., Inc. v. U.S.*, 512 F.2d 1065, 1071 (Ct. Cl. 1975); *see also Orthopedic Equip. Co. v. U.S.*, 702 F.2d 1005, 1011 (Fed. Cir. 1983) (quoting with approval *Jacobson Bros.*). We find, based on our review of the record before us, that Petitioner’s stated level of ordinary skill in the art is reasonable because it is consistent with the evidence at this stage of the proceeding, including the asserted prior art and, for the purposes of this Final Written Decision, we adopt Petitioner’s definition.

C. Claim Construction

In an *inter partes* review, claim terms in an unexpired patent are given their broadest reasonable construction in light of the specification of the patent in which they appear. 37 C.F.R. § 42.100(b); *see also Cuozzo Speed Techs., LLC v. Lee*, 136 S. Ct. 2131, 2142–46 (2016) (concluding that 37 C.F.R. § 42.100(b) “represents a reasonable exercise of the rulemaking authority that Congress delegated to the Patent Office”). Under the broadest reasonable construction standard, claim terms are given their ordinary and customary meaning, as would be understood by one of ordinary skill in the art in the context of the entire disclosure. *In re Translogic Tech., Inc.*, 504 F.3d 1249, 1257 (Fed. Cir. 2007). Also, we are careful not to read a particular embodiment appearing in the written description into the claim if the claim language is broader than the embodiment. *See In re Van Geuns*, 988 F.2d 1181, 1184 (Fed. Cir. 1993) (“[L]imitations are not to be read into the claims from the specification.”).

Petitioner indicates that the parties filed a Joint Memorandum on Claim Construction (Ex. 1041) in the related district court action identified above. Pet. 14. Petitioner also indicates that Patent Owner, in the related

district court action, served infringement contentions (Ex. 1039) including an exhibit (Ex. 1040) indicating how Patent Owner “defines and/or construes” the challenged claims. Pet. 15. Based on these alleged constructions from the district court action, Petitioner proposes constructions for “frame,” “peripheral anchor(s),” “central portion located between the plurality of peripheral anchors,” “band,” “first band,” “second band,” “flexible valve element,” “U-shaped elements/U-shaped frame elements,” “flexibly resilient,” “junction,” “convex upstream side,” and “concave downstream side.” Pet. 15–17 (citing Ex. 1040; Ex. 1041).

Patent Owner proposes constructions for “each of said frame elements has a distance between its respective ends,” “plurality of U-shaped frame elements sized and shaped for insertion,” “attached to,” and “joined together generally midway between respective ends.” PO Resp. 4–16.

In this Final Written Decision, we construe only those claim terms in controversy, and we do so only to the extent necessary to resolve the controversy. *See Wellman, Inc. v. Eastman Chem. Co.*, 642 F.3d 1355, 1361 (Fed. Cir. 2011) (“claim terms need only be construed ‘to the extent necessary to resolve the controversy’”) (quoting *Vivid Techs., Inc. v. Am. Sci. & Eng’g, Inc.*, 200 F.3d 795, 803 (Fed. Cir. 1999)). Furthermore, we expressly interpret below only those claim terms that require analysis to resolve arguments related to the patentability of the challenged claims. In view of our analysis discussed below, construing these terms is not necessary for us to assess the asserted grounds of unpatentability. Therefore, we determine that only the claim terms addressed below require express construction.

1. *Band*

Each of independent claims 1, 10, 18, 28 recites a “band.” Independent claims 17 and 30 both recite a “first band” and a “second band.” Petitioner asserts that “band” should be construed as “[a] structure generally in the shape of a circular strip or ring; a band can be integrated with the frame.” Pet. 16. Patent Owner does not propose a construction for the term “band.”

In the related district court action, the U.S. District Court for the Eastern District of Texas issued a Claim Construction Memorandum Opinion and Order. Ex. 2002. A district court’s interpretation of claim terms may be useful in our claim construction and must be considered in our analysis. *See Knowles Elecs. LLC v. Iancu*, 886 F.3d 1369, 1376 (Fed. Cir. 2018) (“While ‘the [PTAB] is not generally bound by a previous judicial interpretation of a disputed claim term[, this] does not mean . . . that it has no obligation to acknowledge that interpretation or to assess whether it is consistent with the [broadest reasonable interpretation] of the term.’” (quoting *Power Integrations, Inc. v. Lee*, 797 F.3d 1318, 1327 (Fed. Cir. 2015))).

With respect to claim 1 of the ’782 patent, the District Court found that the claim language “expressly recites ‘a band *attached* to the frame,’ which implies that the band is not part of the frame.” Ex. 2002, 37. The District Court also found “the specification [of the ’782 patent] does not teach that the ‘band’ could be both integral with the frame *and* attached to the frame,” and expressly rejected the interpretation that a band can be

integral with the frame. *Id.* at 38–39. The District Court then construed “band” to have its plain meaning. *Id.* at 40.

We agree with the District Court’s reasoning that a band should not be interpreted as being integral with the frame. In addition, we find the remainder of Petitioner’s proposed construction—a structure generally in the shape of a circular strip or ring—to be a good reflection of the plain meaning, although we disagree that a band is necessarily circular because a band in the ’782 patent could assume another closed shape such as an oval. Therefore, we construe “band” as “a structure generally in the shape of a closed strip or ring.”

2. *Convex Upstream Side/Concave Downstream Side*

Each of independent claims 10, 17, 18, and 29 recites that a flexible valve element having a “convex upstream side” and a “concave downstream side.” The District Court declined to adopt an express construction for these terms and construed them to have their plain meaning. Ex. 2002, 63–64.

Petitioner asserts that “convex upstream side” should be construed as “[a] valve element having an upstream side that bulges out in the upstream direction,” and “concave downstream side” should be construed as “[a] valve element having a downstream side that bulges away from the downstream direction.” Pet. 17. Petitioner neither analyzes nor cites evidence from the Specification or prosecution history of the ’782 patent in support of its position. *Id.* (citing Ex. 1040, 26–28, 40–41, 48–49, 81–82; Ex. 1041, 4).

The phrase “convex upstream side” plainly limits the “side” of the flexible valve element to a side that both faces “upstream” and exhibits a

“convex” shape. Similarly, “concave downstream side” refers to a “side” that faces “downstream” and exhibits a “concave” shape. A plain reading of the phrases also indicates that the entire sides, not just a portion, are “convex” or “concave.”

The Specification supports a plain reading of “convex upstream side” and “concave downstream side” as referring to characteristics of the sides as a whole rather than only a portion of each side. Claims should be interpreted in a manner that “corresponds with what and how the inventor describes his invention in the specification.” *In re Smith Int’l, Inc.*, 871 F.3d 1375, 1383 (Fed. Cir. 2017). The Specification only describes flexible valve elements in which the entire side of the valve element is either convex or concave as follows.

The valve element 22 has a *convex upstream side 50 facing an upstream region (e.g., the left atrium LA)* when the frame 20 is anchored between the cusps C of the damaged heart valve (e.g., mitral valve M) in a position between the upstream region and a downstream region; and a *concave downstream side 52 opposite the upstream side facing the downstream region (e.g., the left ventricle LV)* when the frame 20 is anchored between the cusps of the damaged heart valve in a position between the upstream region and the downstream region.

Ex. 1001, 6:25–35 (emphases added). Figure 2 and the pertinent portion of Figure 1, which are reproduced below left and right respectively, illustrate convex upstream side 50 and concave downstream side 52.

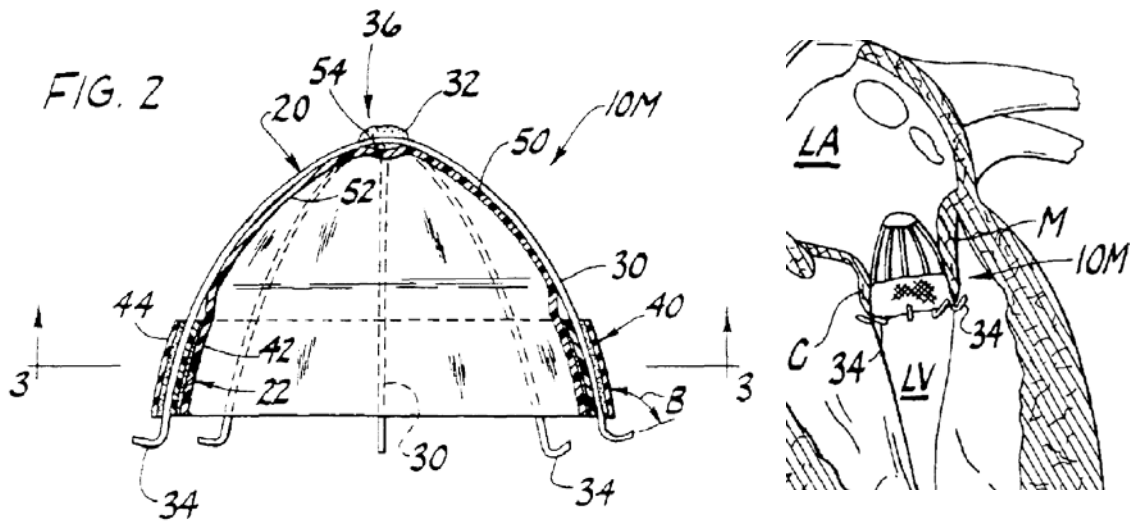
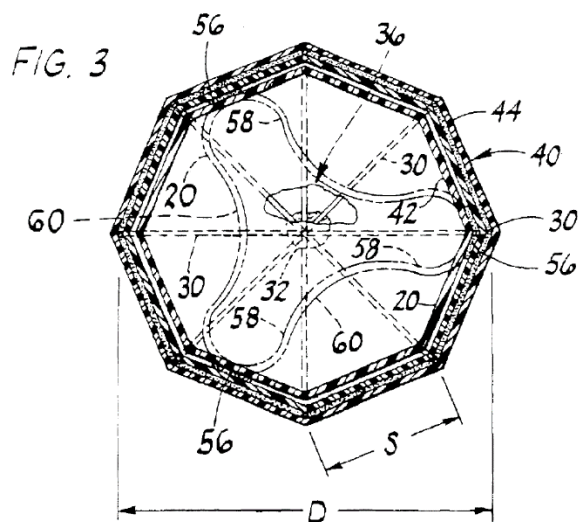

Figure 2, reproduced above left, is a cross-sectional view of valve 10M illustrating convex upstream side 50 and concave downstream side 52 of flexible valve element 22. *Id.* at 4:8. The portion of Figure 1 that is reproduced above right illustrates valve 10M placed with its concave side facing the left ventricle LV (i.e., the downstream region) and the convex side facing the left atrium LA (i.e., the upstream region). *Id.* at 4:6–7, 6:25–35.

The entirety of upstream side 50 is convex and the entirety of downstream side 52 is concave when valve element 22 is in the “closed position” as shown in the solid-line depiction of valve element 22 in Figures 2 (above) and 3 (reproduced at right). *Id.* at 6:35–51. Figure 3 illustrates an open valve element 22 in phantom lines such that valve element 22 defines



openings 60 to permit blood flow that are defined by flaps 58 between adjacent attachment points 56. *Id.* at 7:10–17. The Specification, therefore,

describes only a valve having a “convex upstream side” and a “concave downstream side” in which the “convex” or “concave” shape of the “side” refers to the overall shape of the entire respective side when the valve is closed.

During the hearing, Patent Owner was asked to identify any evidence of record from the Specification or prosecution history that weighed against interpreting “convex” and “concave” as referring to the overall shapes of the opposing sides of the claimed flexible valve element in their entirety, and Patent Owner identified none. Tr. 72:16–79:11.

Based on the plain meaning of “convex upstream side” and “concave downstream side” and the description of the invention in the Specification, we conclude that the overall shape of the entire “upstream side” of the flexible valve element is convex, and the overall shape of the entire “downstream side” of the flexible valve element is concave.

3. *Attached To*

Each of the independent claims recites a flexible valve element “attached to” a frame, a central portion of a frame, or a junction of frame elements. Patent Owner argues “attached to” should be construed as “directly attached to.” PO Resp. 8. According to Patent Owner, the ’782 patent contemplates direct attachment. *Id.* at 9. In particular, Patent Owner argues that the Specification of the ’782 patent confirms that the flexible valve element is directly attached to the frame. *Id.* (citing Ex. 1001, 7:1–12). The portion of the Specification cited by Patent Owner, however, states “the flexible valve element 22 is attached to the frame 20, *and more particularly to the band 40*, at several attachment points around the frame.

Ex. 1001, 7:1–12 (emphasis added). Thus, the Specification describes particularly that the flexible valve element can be attached to the frame via band 40, rather than directly to the frame. As such, the Specification does not support Patent Owner’s proposed construction, and we decline to adopt it here.

The Specification of the ’782 patent indicates that the flexible valve element is attached to the frame in two ways: (1) directly by being bonded to the central portion 36 of frame 20 and (2) indirectly by being attached to band 40 at attachment points 56. *Id.* Because the inventor describes both direct and indirect methods of attaching the flexible valve element to the frame, we interpret “attached to” as encompassing both direct and indirect ways of attaching the flexible valve element to the frame. *See In re Smith*, 871 F.3d at 1383 (Claims should be interpreted in a manner that “corresponds with what and how the inventor describes his invention in the specification.”).

D. Asserted Anticipation by Bessler

Petitioner contends claims 1, 2, 4–8, 10–13, 17–19, 21, 22, and 25–30 are anticipated under 35 U.S.C. § 102(a), (e) by Leonhardt. Pet. 3, 18–42. Petitioner relies upon the testimony of Dr. Dasi (Ex. 1003) in support of its contentions. *Id.* Patent Owner disputes Petitioner’s contentions. PO Resp. 16–30. Patent Owner cites the testimony of Dr. Chronos (Ex. 2026) in support.

1. Overview of Bessler

Bessler “relates to novel heart valves that are especially adapted for placement using minimally invasive surgical techniques and to the method

and device useful for such placement.” Ex. 1008, 1:8–11. Figure 4 of Bessler is reproduced below.

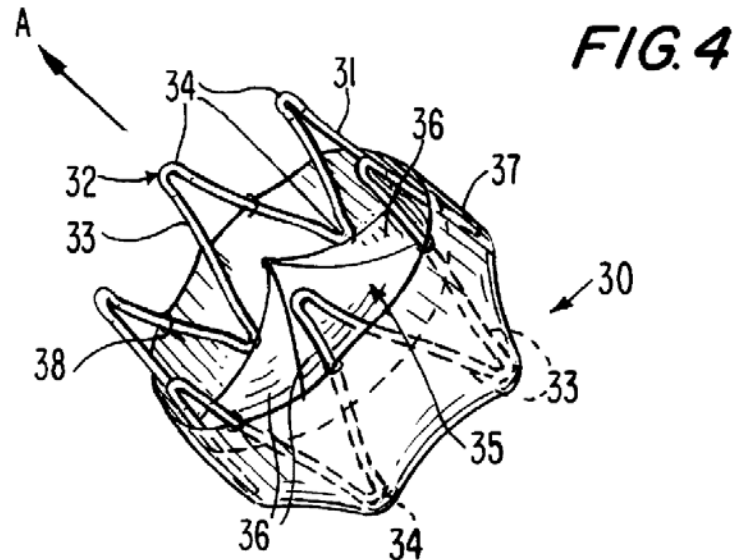

Figure 4 depicts artificial heart valve 30 having a generally cylindrical shape defined by stent member 32. *Id.* at 5:28–31. Stent member 32 is a wire formed into a closed zig-zag configuration having straight sections 33 joined by bends 34. *Id.* at 5:31–34. Flexible valve member 35 extends across the cylindrical stent and includes a plurality of leaflets 36. *Id.* at 5:34–37. Leaflets 36 “are the actual valve and allow for one-way flow of blood.” *Id.* at 5:37–38. Cuff portion 37 extends from the periphery of the leaflet portion and along walls 31 of stent member 32 and is attached to the stent member by sutures 38. *Id.* at 5:38–42. In another embodiment, the stent member includes a plurality of barbs 64 for holding the valve in place. *Id.* at 5:67–6:2, Fig. 7.

The configuration and flexible, resilient material of construction of stent member 32 allows the valve to collapse into relatively small cylinder 40. *Id.* at 5:43–45, Fig. 5. Bessler also discloses device 90

including flexible catheter 91 for percutaneous and transluminal delivery of a heart valve to the desired site. *Id.* at 7:26–30, Figs. 12, 13. Device 90 includes hollow pusher member 93 disposed within catheter 91 and guidewire 94 disposed within pusher member 93 to guide the distal end of the catheter to the desired site. *Id.* at 7:33–38. Means 96 disposed with pusher member 93 holds a collapsed valve in the distal end of catheter 91 and allows the valve to be released when desired. *Id.* at 7:38–40.

2. *Independent Claim 1*

- a) *an artificial valve for repairing a damaged heart valve having a plurality of cusps separating an upstream region from a downstream region*

Petitioner argues that “Bessler describes a valve for replacement of a diseased or defective heart valve comprised of a frame, a band, and a [flexible valve element] to be disposed in a native valve annulus between upstream and downstream regions.” Pet. 19 (citing Ex. 1008, 2:25–28, 2:57–62, 3:46–4:21, 7:26–67, Figs. 1–7, 14, 15; Ex. 1003 ¶ 56); *id.* at 29. Although the burden remains on the Petitioner to prove unpatentability (*see Dynamic Drinkware*, 800 F.3d at 1378), we note that Patent Owner does not dispute Petitioner’s assertion.

We are persuaded by Petitioner’s argument. Bessler’s artificial heart valve 30 is intended to replace diseased or defective heart valves. Ex. 1008, 2:55–57.

- b) *a flexibly resilient frame sized and shaped for insertion in a position between the upstream region and the downstream region*

Petitioner argues that Bessler’s stent is a flexibly resilient frame. Pet. 19 (citing Ex. 1003 ¶ 57); *id.* at 30. Petitioner also argues that this

frame “is sized and shaped for insertion or placement between upstream and downstream regions.” *Id.* at 19 (citing Ex. 1008, 2:25–28, 2:57–62, 4:53–5:3, 7:26–67); *id.* at 30.

On the full record, we are persuaded by Petitioner’s position. Bessler discloses that “[t]he configuration of the stent member 32 and the flexible, resilient material of construction allows the valve to collapse into a relatively small cylinder,” but the “valve will not stay in its collapsed configuration without being restrained. Once the restraint is removed, the self-expanding stent member 32 will cause the artificial heart valve to take its expanded configuration.” Ex. 1008, 5:43–49. In view of this disclosure, we agree that Bessler’s stent is a flexibly resilient frame.

In response, Patent Owner argues

Bessler requires *removal* of the native heart valve prior to insertion of the bioprosthetic valve, (Ex. 1008 at 2:55–57 and 2:63–67), so there is no “damaged heart valve having a plurality of cusps” remaining to separate the “upstream region” from the “downstream region.” (Ex. 2026 § 3.1.1.2). As stated in the ‘782 Patent’s Background of the Invention, “[t]he Bessler procedure includes excision [and] vacuum removal of the native valve[.]” (Ex. 1001 at 2:16–17; Ex. 2026 § 3.1.1.2). At best, Bessler’s valve is “sized and shaped for insertion” in the much larger space left following the excision and removal of a damaged heart valve, not “sized and shaped for insertion” into a damaged heart valve having a plurality of cusps. (Ex. 2026 § 3.1.1.2). Thus Bessler does not disclose a valve with a frame that is “sized and shaped for insertion between the upstream region and the downstream region.” *Id.*

PO Resp. 17–18.

We are not persuaded by this argument. Removal of the damaged heart valve that separates the upstream and downstream regions does not mean that the upstream and downstream regions no longer exist. These regions still exist and are separated by the artificial valve that Bessler describes is placed at the same location from which the damaged heart valve is removed. *See* Ex. 1008, 2:63–66 (“A cutting mechanism is used to remove the diseased or defective heart valve, and then the replacement valve is inserted percutaneously to the site.”). Furthermore, Patent Owner’s assertion that Bessler’s valve is inserted in a “much larger space left following the excision and removal of a damaged heart valve” is not persuasive because the claim language requires only that the frame is sized and shaped for insertion *in a position* between the upstream region and the downstream region. The claim language does not require the frame be sized and shaped for insertion into a damaged heart valve.

c) the frame having a plurality of peripheral anchors for anchoring the frame in the position between the upstream region and the downstream region and a central portion located between the plurality of peripheral anchors

Petitioner argues that Bessler’s barbs 64 are peripheral anchors. Pet. 20 (citing Ex. 1008, 4:12–21, 5:67–6:2, 7:26–67, Fig. 7; Ex. 1003 ¶¶ 60–61); *id.* at 30–31. Alternatively, Petitioner argues that bends 34 of Bessler’s stent member 32 can constitute peripheral anchors. *Id.* at 20–21 (citing Ex. 1008, 5:19–21, 5:28–35, 5:51–60, 6:7–11, Figs. 1–4; Ex. 1003 ¶¶ 60–61); *id.* at 30–31. In addition, Petitioner argues that the claimed central portion “would be the straight sections 33, 53 between the bends 34, 54 . . . or the portions of the stent disposed between the first and second

circles of barbs.” *Id.* at 21 (citing Ex. 1008, 4:12–21, 5:28–35, 5:55–6:2, 7:43–67, FIGS.1, 4, 6, 7, 14, 15; Ex. 1003 ¶¶ 59–62); *id.* at 31.

On the full record, we find Petitioner’s contention that Bessler’s barbs 64 are peripheral anchors persuasive. Bessler discloses that barbs 64 hold the valve in place once it has been appropriately positioned. Ex. 1008, 5:67–6:2. And Figure 7 of Bessler depicts barbs 64 as being located on the periphery of stent member 32. We are also persuaded that the portion of Bessler’s stent member located between the upper and lower sets of barbs as shown in Figure 7 defines a central portion of the frame in that it is centrally located along the longitudinal axis of the frame.

d) a band attached to the frame limiting spacing between adjacent anchors of said plurality of peripheral anchors

Petitioner points to Bessler’s cuff as being the claimed band. Pet. 23 (citing Ex. 1008, 3:54–64, 4:4–11, 5:24–27, Figs. 1–5, 7); *id.* at 31–32. Petitioner asserts that this band limits spacing between adjacent anchors (i.e., barbs 64) because Bessler’s cuff “is shown as being tight against the self-expanding stent” and, thus, “would restrict the expansion of the self-expanding frame.” *Id.* at 24 (citing Ex. 1008, 5:15–27, 40–43, Figs.1, 4; Ex. 1003 ¶ 70).

We are persuaded by Petitioner’s assertion that Bessler’s cuff portion 37 is a band. Patent Owner does not challenge this assertion, but disputes that the cuff limits spacing between adjacent anchors. PO Resp. 18–20. Specifically, Patent Owner argues that Bessler’s written disclosure does not suggest the cuff is “tight against the self-expanding stent.” *Id.* at 19 (citing Ex. 1008, 5:15–27, 40–43, Figs. 1, 4). Patent Owner argues further

that “even if a cuff appears ‘tight’ on a frame, that does not mean that the cuff is ‘limiting spacing’ between the frame’s elements.” *Id.* at 19–20. Petitioner, however, asserts that the cuff is *shown* in Bessler as being tight against the self-expanding stent, and we agree that Figure 4 of Bessler shows cuff portion 37 closely encompassing stent member 32. We are persuaded that given the arrangement shown Figure 4, cuff portion 37 will limit the expansion of the self-expanding frame to some extent, and thus limit the spacing between anchors 64. Furthermore, Dr. Dasi testifies that, based on this depiction, one of ordinary skill in the art “would expect that this cuff would restrict the expansion of the self-expanding frame.” Ex. 1003 ¶ 70. We credit Dr. Dasi’s uncontroverted testimony, and, thus, on the full record, we are persuaded by Petitioner’s argument that Bessler discloses a band that is attached to the frame and limits spacing between adjacent anchors.

e) a flexible valve element attached to the central portion of the frame and adjacent the band, said valve element being substantially free of connections to the frame except at the central portion of the frame and adjacent the band

Petitioner argues

According to Bessler “[t]he valve member is flexible, compressible, host-compatible, and non-thrombogenic.” (Ex.1008 col.6:19–20 (emphasis added).) It can be porcine or synthetic. (*Id.* 6:20–31.) Bessler also teaches that the valve is mounted to the central portion of the frame — “central portion” having been discussed in connection with the flexibly resilient frame above. Indeed, as illustrated in FIG.7, FVE 63 can be disposed centrally and attached to “crowns” or the tops of “smaller waves” 61. (*Id.* 5:60-6:2, FIG.7.) Thus Bessler teaches a FVE attached to the frame and in particular to a central portion

thereof as Defined. (See Claim Chart 1 Bessler “Flexible Valve Element”; Ex.1003 ¶¶72, 75.)
Pet. 24–25; see also *id.* 32 (portion of claim chart identifying passages and figures of Bessler allegedly disclosing the flexible valve element). Petitioner also argues that Bessler’s flexible valve element is mounted in the central portion of the frame adjacent the band and substantially free of other connections. *Id.* at 26–27; *id.* at 32.

Patent Owner argues that “[a]lthough Bessler discloses that the *cuff* is attached to the stent, it does not disclose that the valve leaflets are attached to the stent or frame and therefore, the ‘flexible valve element’ is not attached to the frame as required by the claims.” PO Resp. 16 (citing Ex. 2026 § 3.1.1.1). We disagree with this argument. First, Patent Owner’s argument is based on its assertion that “attached to” should be construed as “directly attached to.” *Id.* We did not adopt this proposed construction, however, for the reasons discussed above. See *supra* § III.C.3.

Second, Bessler discloses a flexible valve member comprising leaflet portion 36 that extends across the cylindrical stent and cuff portion 37 that extends from the periphery of the leaflet portion and is attached to a longitudinally central portion of stent member 32 by sutures 38. Ex. 1008, 5:34–42, Fig. 4. Figure 7 of Bessler shows a flexible valve member 63 having a similar configuration. *Id.* at 5:61–6:2. With this configuration, the leaflet portion, which corresponds to the claimed flexible valve element, is attached to a central portion of the stent member (i.e., the frame) by virtue of being connected to the cuff portion, which is directly attached to the stent member. This indirect attachment of the leaflet portion to the stent member

satisfies the claim language, which does not require a direct attachment, as we have construed.

For these reasons, we are persuaded on the full record that Bessler discloses a flexible valve element attached to the central portion of the frame and adjacent the band.

f) said valve element having an upstream side facing said upstream region when the frame is anchored in the position between the upstream region and the downstream region and a downstream side opposite the upstream side facing said downstream region when the frame is anchored in the position between the upstream region and the downstream region

Petitioner argues that Bessler’s flexible valve element has upstream and downstream sides because “Bessler notes that its valve device has upstream and downstream sides corresponding to inflow and outflow ends.” Pet. 25 (citing Ex. 1008, 4:12–21 (barbs facing upstream and downstream directions on the inflow and outflow sides of the valve)).

On the full record before us, we are persuaded by Petitioner’s argument that Bessler discloses a flexible valve element having an upstream side facing an upstream region and downstream side facing a downstream region, which Patent Owner does not dispute.

g) said valve element moving in response to a difference between fluid pressure in said upstream region and fluid pressure in said downstream region . . .

Petitioner argues that claim 1, among other claims, includes “lengthy recitations merely describing the general operation of native and replacement valves, which were known *per se*.” Pet. 27 (citing Ex. 1001, 1:42–2:19; Ex. 1003 ¶ 76). Petitioner also argues that Bessler’s flexible

valve element functions the same way as a tricuspid valve and, therefore, meets these limitations. *Id.* (citing Ex. 1008, 3:65–4:3, 4:63–5:14, 5:36–43, 6:19–24, Fig. 4; Ex. 1003 ¶ 77); *id.* at 35–36.

We are persuaded by Petitioner’s arguments. Bessler discloses that “[t]he arcuate portion of the valve means contains at least one slit to form leaflets which open in response to blood flow in one direction and close in response to blood flow in the opposite direction.” Ex. 1008, 3:65–4:1; *see also id.* at 2:61–62 (disclosing valve means that permit flow in only one direction). As such, we are persuaded that Bessler’s valve moves between open and closed positions in response to a difference in fluid pressure and allows flow in a single direction. Also, because Bessler discloses allowing flow in only one direction, one of ordinary skill in the art would understand that the valve would be positioned to allow downstream flow (between an upstream region and a downstream region), as opposed to upstream flow.

For these reasons, we are persuaded on the full record that Bessler discloses the valve movement limitations of claim 1.

h) Conclusion

For the above reasons, we determine that Petitioner has shown, by a preponderance of the evidence, that independent claim 1 is anticipated by Bessler.

3. Dependent Claim 2

Claim 2 depends from claim 1 and recites that the flexibly resilient frame is collapsible to a configuration having a maximum width less than about 18 millimeters. Ex. 1001, 10:61–63.

Petitioner argues that the limitation of the maximum width being less than about 18 millimeters is met by Bessler because Bessler discloses that the diameter of the non-collapsed stent member ranges from 15–35 millimeters, and the stent must be collapsed further to be inserted such that the diameter in the compressed state falls within the range claimed. Pet. 22–23 (citing Ex. 1008, 3:51–55, 4:53–66, 6:14–18, 7:21–67; Ex. 1003 ¶ 65); *id.* at 38 (arguing same reasoning applies to claim 2).

We agree with Petitioner’s analysis of claim 2 and adopt it as our own. Because Bessler discloses a non-collapsed diameter that is less than 18 millimeters, the diameter of Bessler’s valve in its collapsed state would also be less than 18 millimeters. Although the burden remains on the Petitioner to demonstrate by a preponderance of the evidence that the claims are unpatentable (35 U.S.C. § 326(e); 37 C.F.R. § 42.1(d)), we note that Patent Owner does not argue separately that the subject matter of dependent claim 2 is not anticipated by Bessler. Accordingly, we determine that Petitioner has shown, by a preponderance of the evidence, that claim 2 is anticipated by Bessler.

4. *Dependent Claims 4 and 5*

Claim 4 depends from claim 2 and further recites the maximum width is less than about 6 millimeters, and claim 5 depends from claim 4 and further recites the maximum width is between about 4 millimeters and about 6 millimeters. Ex. 1001, 11:1–7.

Petitioner argues that Bessler discloses its valve is collapsed and delivered to the implantation site percutaneously using standard techniques including access through the femoral artery. Pet. 38–39 (citing Ex. 1008,

2:65–67, 4:53–60, 7:26–67; 8:7–15, 8:48–50). Thus, according to Petitioner, one of ordinary skill in the art would have known that a device for such a procedure would require a compressed diameter of about 6 millimeters or less, such that the claimed ranges are obvious. *Id.* (citing Ex. 1003 ¶¶ 65, 80–81). This argument, however, does not establish that claims 4 and 5 are anticipated by Bessler. Accordingly, we determine that Petitioner has not shown, by a preponderance of the evidence, that claims 4 and 5 are anticipated by Bessler.

5. *Dependent Claims 6 and 8*

Claims 6 and 8 both depend from claim 1. Petitioner provides detailed explanations supported by the testimony of Dr. Dasi and specific citations to Bessler indicating where in the reference the limitations of claims 6 and 8 are taught. Pet. 39, 40 (citing Ex. 1008, 5:28–43, 5:51–6:2, Figs. 1–7; Ex. 1003 ¶¶ 63–64, 72, 82, 84). We agree with Petitioner’s analyses of claims 6 and 8 (which Patent Owner does not argue separately) and adopt them as our own.

Accordingly, we determine that Petitioner has shown, by a preponderance of the evidence, that claims 6 and 8 are anticipated by Bessler.

6. *Dependent Claim 7*

Claim 7 depends from claim 6 and further recites that the flexible valve element is attached at a plurality points so as to form flaps extending between the attachment points. Ex. 1001, 11:12–18. Petitioner argues that Bessler’s valve element meets this limitation to the same extent the flexible valve element identified in Patent Owner’s infringement contentions from

the related district court action meets the limitation. Pet. 39 (citing Ex. 1003 ¶ 83).

In relying on the infringement contentions solely, however, Petitioner fails to cite proper evidence showing how Bessler meets the subject matter of claim 7 and, thus, fails to provide the “detailed explanation” required to meet its burden. Furthermore, Petitioner’s reliance on Patent Owner’s infringement contentions is not persuasive because there is no basis in the record to conclude that the product accused of infringement in the related district court action has the same elements as Bessler’s device.

For these reasons, we determine that Petitioner has not shown, by a preponderance of the evidence, that claim 7 is anticipated by Bessler.

7. *Claims 10–13, 17, 18, 19, 21, 22, 25–27, and 29*

Each of independent claims 10, 17, 18, and 29 recites a flexible valve element attached to the frame and having a convex upstream side and a concave downstream side. Ex. 1001, 11:38–44, 12:31–35, 13:1–6, 15:8–12. Petitioner argues that, according to Patent Owner’s infringement contentions, the convex upstream side and concave downstream side limitations are met by a native tricuspid heart valve. Pet. 25. Relying on the testimony of Dr. Dasi, Petitioner argues to the extent the flexible valve element identified in the infringement contentions has convex upstream and concave downstream sides, the valve of Bessler does as well. *Id.* at 26 (citing Ex. 1008, 6:19–24; Ex. 1003 ¶ 74). Petitioner also argues that Bessler describes its valve as “arcuate,” and illustrates the valve forming a generally concave downstream side. *Id.* (citing Ex. 1008, 3:54–64, 5:20–27, 5:36–42, Fig. 4; Ex. 1003 ¶ 74).

We determine that a tricuspid porcine valve does not anticipate either the convex upstream side or the concave downstream side as we have construed these terms. *See supra* § III.C.2. Although it seems reasonable to conclude that each one of the three cusps of a tricuspid valve individually has a convex upstream side and a concave downstream side,² this means only that the upstream *side of the valve* has three separate convex surfaces—not that the upstream side of the valve as a whole is convex. Similarly, the downstream side of the valve has three separate concave surfaces such that the downstream side as a whole is not concave.

For these reasons, we determine that Petitioner has not met its burden of establishing that Bessler discloses a flexible valve element having a convex upstream side and a concave downstream side. Accordingly, Petitioner has not shown, by a preponderance of the evidence, that independent claims 10, 17, 18, and 29 are anticipated by Bessler. Also, Petitioner has not shown, by a preponderance of the evidence, that claims 11–13, depending from claim 10, and claims 19, 21, 22, and 25–27, depending from claim 18, are anticipated by Bessler.

8. *Independent Claim 28*

Independent claim 28 recites an artificial valve for repairing a damaged heart valve in combination with an instrument for inserting the artificial valve in a patient. Ex. 1001, 13:66–14:3. The artificial valve of claim 28 has substantially the same limitations recited in claim 1 plus the limitation of the frame being collapsible to a configuration having a

² The tricuspid valve depicted in Figure A on page 5 of the Petition suggests such a configuration.

maximum width less than about 18 millimeters that is also recited in claim 2. *Id.* at 14:5–45.

Petitioner makes the same arguments for these claim 28 limitations as it did in connection with the similar limitations of claims 1 and 2. Pet. 19–28, 38. For the reasons discussed above in connection with claims 1 and 2, we are persuaded on the full record that Bessler discloses the artificial valve limitations of claim 28. *See supra* §§ III.D.2, III.D.3.

Claim 28 also recites that the instrument includes:

a holder having a hollow interior sized for holding the artificial valve when the frame is in the collapsed configuration;

an elongate manipulator attached to the holder for manipulating the holder into position between the upstream region and the downstream region; and

an ejector mounted in the hollow interior of the holder for ejecting the artificial heart valve from the hollow interior of the holder into position between the upstream region and the downstream region.

Ex. 1001, 14:46–56.

Petitioner argues that Bessler discloses the instrument of claim 28. Pet. 28. Specifically, Petitioner argues that “Bessler’s hollow distal end of its flexible catheter which can be inserted into a vessel is the ‘holder.’” *Id.* (citing Ex. 1008, 4:53–58, 7:26–67, Figs. 12–15). We agree that Bessler discloses using a catheter for implanting the artificial heart valve percutaneously and transluminally, wherein the hollow distal end of the catheter carries the artificial heart valve in its collapsed configuration and can thus be considered a “holder” as recited. Ex. 1008, 4:53–58.

Petitioner also argues that the proximal end of catheter 91 “is the manipulator which is used to position the distal holder” and Bessler’s “pusher member 93 [is] disposed within the catheter to push the valve from the holder.” Pet. 28 (citing Ex. 1008, 4:60–5:1, 5:3–14, 7:26–67, Figs. 12–15; Ex. 1003 ¶ 79).

We disagree, however, that Bessler discloses that the proximal end of catheter 91 manipulates the catheter’s distal end or holder into the desired position. Instead, Bessler discloses that guidewire 94 guides the distal end of catheter 91 to the desired site. Ex. 1008, 7:35–38. Accordingly, the Petition fails to establish that all elements of the instrument of claim 28 are disclosed by Bessler.

For this reason, we determine that Petitioner has not shown, by a preponderance of the evidence, that independent claim 28 is anticipated by Bessler.

9. *Independent Claim 30*

Claim 30 requires an artificial valve for repairing a damaged heart valve comprising, in pertinent part, a first band surrounding a frame and a second band surrounding the frame downstream of the first band. Ex. 1001, 16:3–13. Petitioner asserts that two different structures of Bessler can correspond to the first band. First, Petitioner argues that “the upstream, inflow portion” of Bessler’s stent can be a band. Pet. 23 (citing Ex. 1008, 4:12–21, 5:15–27, 5:51–6:2, Figs. 1–5, 7). Second, Petitioner argues Bessler’s cuff can be a band. *Id.* (citing Ex. 1008, 3:54–64, 4:4–11, 5:24–27, Figs. 1–5, 7). Regarding the second band, Petitioner argues Patent Owner’s infringement contentions the related district court action illustrate

this band as a circumferential row of frame elements disposed downstream from the first band. *Id.* at 24 (citing Ex. 1040, 39, 92). Petitioner then asserts that “Bessler describes a downstream portion, which is uncovered by the cuff, which is a second band.” *Id.* (citing Ex. 1008, Figs. 1–5; Ex. 1003 ¶ 71).

These end portions of Bessler, however, define a substantial part of stent member 32. Thus, it is not clear how these portions could be both a part of the frame and a band that is *surrounding the frame* as required by claim 30. As the District Court noted in the related action, the claim language “a band *attached* to the frame” implies the band is not part of the frame. Ex. 2002, 37. The language a “band *surrounding* the frame” similarly implies the band is not part of the frame. In fact, the District Court expressly rejected the interpretation that “a band can be integrated with the frame.” *Id.* at 39. Accordingly, we are not persuaded that Bessler discloses more than one band.

For the above reasons, we determine that Petitioner does not establish adequately that Bessler discloses first and second bands as recited in claim 30. Accordingly, for at least the foregoing reasons, Petitioner has not shown, by a preponderance of the evidence, that independent claim 30 is anticipated by Bessler.

E. Asserted Obviousness over Bessler and Andersen

Petitioner contends claims 1, 2, 4–8, 10–13, 17–19, 21, 22, and 25–30 would have been obvious over Bessler and Andersen. Pet. 41–47. Patent Owner disputes Patent Owner’s contentions. PO Resp. 30–37.

In asserting this ground, Petitioner asserts “[t]o the extent one were to argue that Bessler’s elements were not exactly shown in the same manner

claimed, the differences would be obvious to a [person having ordinary skill in the art] in view of Andersen.” Pet. 41. Petitioner argues that Andersen, like Bessler, discloses a valve comprising “a stent and a valve and band mounted within, which can be placed transluminally into a heart annulus defining upstream and downstream regions.” *Id.* at 42 (citing Ex. 1006, 2:34–68, 3:1–4, 3:37–42, 5:9–39, 6:3–44, Figs. 1, 2, 8–10; Ex. 1003 ¶ 89). According to Petitioner, Andersen’s stent is a flexibly resilient frame including two or more rings having U-shaped members joined together midway between the respective ends. *Id.* at 43 (citing Ex. 1006, 2:39–42, 2:45–52, 2:60–64, 3:16–17, 5:9–28, 6:66–7:12, 7:17–23, Figs. 1, 2; Ex. 1003 ¶ 90). Petitioner further argues that the extremities of the rings can be peripheral anchors and the region between these peripheral anchors is a central portion. *Id.* (citing Ex. 1006, 5:33–35, 6:54–64, Figs. 1, 2, 8, 9; Ex. 1003 ¶ 90). Last, Petitioner asserts that Andersen uses a biological valve obtained from a slaughtered pig and including a band of root tissue. *Id.* at 43–44 (citing Ex. 1006, 2:34–37, 5:11–17, 5:29–39, 7:12–16; Ex. 1003 ¶ 91).

Next, Petitioner asserts that “[i]t would have been obvious to interchange *elements* of Andersen for those of Bessler” because both references relate to replacement valves having a collapsible and expandable stent, a band, and flexible valve element that can be a porcine valve. *Id.* at 44 (citing Ex. 1003 ¶¶ 93–96) (emphasis added). Petitioner also asserts that one of ordinary skill in the art “would have reason to consider using the Andersen stent, *or aspects of it*, in place of the Bessler stent. *Id.* (emphasis added).

Patent Owner argues that one of ordinary skill in the art would not have been to combine Bessler and Andersen because Bessler teaches away from using features of Andersen. PO Resp. 31 (citing Ex. 2026 § 3.1.2.1). In particular, Patent Owner points to a portion of Bessler’s specification that discusses perceived problems of a technique for replacing heart valves described in an article authored by H. R. Andersen, among others, who is presumably one of the named inventors of the Andersen reference. *Id.* at 31–32 (citing Ex. 1008, 1:64–2:17; Ex. 2026 § 3.1.2.1). As Petitioner correctly replies, however, Patent Owner does not establish that the alleged problems Bessler identifies in connection with the technique of the Andersen article also exist in connection with the device disclosed in the Andersen reference. See Reply 12. Thus, on the record before us, we are not persuaded that Bessler criticizes or discredits the Andersen valve to the extent that it would discourage one of ordinary skill in the art from investigating the Andersen valve. See *DePuy Spine, Inc. v. Medtronic Sofamor Danek, Inc.*, 567 F.3d 1314, 1327 (Fed. Cir. 2009) (quoting *In re Fulton*, 391 F.3d 1195, 1201 (Fed. Cir. 2004)) (holding a reference does not teach away if it “does not ‘criticize, discredit, or otherwise discourage’ investigation into the invention claimed”).

Patent Owner also argues that Petitioner has failed to put forth a proper obviousness analysis regarding Bessler and Andersen because it fails to explain how or why one of ordinary skill in the art would interchange elements of Andersen for elements of Bessler. PO Resp. 33.

We agree with Patent Owner. Petitioner states that it would have been obvious to interchange elements of Andersen for elements of Bessler

(Pet. 44), but never identifies which specific elements are interchanged. The most specific statement from Petitioner regarding combining Bessler and Andersen is to use “the Andersen stent, *or aspects of it*, in place of the Bessler stent” (*id.* (emphasis added)), but even this statement does not describe the proposed modification with sufficient particularity. Also, the Petition does not identify any differences between the claimed subject matter and Bessler that the teachings of Andersen would satisfy. *See Graham*, 383 U.S. at 17–18.

Dr. Dasi’s testimony similarly lacks particularity. For example, Dr. Dasi opines that “swapping one stent for another, one band for another, one [flexible valve element for another, is the application of routine engineering,” and it would have been “readily apparent to try *various combinations* of these known elements.” Ex. 1003 ¶ 93 (emphases added). Thus, like the Petition, Dr. Dasi does not identify the specific elements that are to be substituted.

Therefore, neither the Petition nor Dr. Dasi indicates with sufficient particularity, as required by 35 U.S.C. § 312(a)(3), what elements of Andersen are interchanged with elements of Bessler and, thus, in what manner Bessler and Andersen are combined. *See Intelligent Bio-Sys., Inc. v. Illumina Cambridge Ltd.*, 821 F.3d 1359, 1369 (Fed. Cir. 2016) (“It is of the utmost importance that petitioners in the IPR proceedings adhere to the requirement that the initial petition identify ‘with particularity’ the ‘evidence that supports the grounds for the challenge to each claim.’”). For this reason, Petitioner has not shown, by a preponderance of the evidence, that

the challenged claims are unpatentable in view of the combination Bessler and Andersen.

We also agree with Patent Owner's argument that Andersen does not cure certain deficiencies of Bessler. *See* PO Resp. 33–36. Although the exact combination of Bessler and Andersen is not clear for the reasons discussed above, we note that Petitioner asserts that Andersen, like Bessler, uses a biological valve obtained from a pig as the flexible valve element. Pet. 43 (citing Ex. 1006, 5:29–39). For the reasons discussed above, however, we determine that the Petition does not establish adequately that porcine tricuspid valve includes a flexible valve element having a convex upstream side and a concave downstream side. *See supra* § III.D.7. Petitioner's reply arguments do not address persuasively how Andersen overcomes this deficiency. *See* Reply 14–16.

F. Asserted Obviousness over Johnson, Bessler, and Imachi

Petitioner contends claims 1, 2, 4–8, 10–13, 17–19, 21, 22, and 25–30 would have been obvious over Johnson, Bessler, and Imachi. Pet. 47–67. Patent Owner disputes Patent Owner's contentions. PO Resp. 38–45.

1. Overview of Johnson

Johnson “relates to a synthetic leaflet aortic or mitral heart valve prosthesis.” Ex. 1021, 1:7–8. Figures 1 and 2 of Johnson are reproduced below.

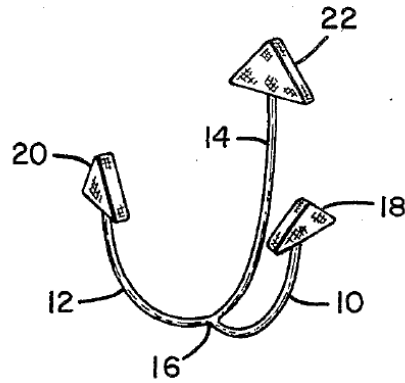

Fig. 1

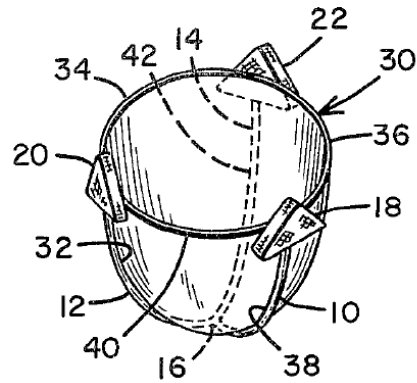

Fig. 2

Figure 1 shows the flexible central framework of a dynamic annulus heart valve, and Figure 2 shows the complete dynamic annulus heart valve. *Id.* at 3:54–58. The framework depicted in Figure 1 comprises three arcuate shaped struts 10, 12, and 14 joined together at point 16. *Id.* at 4:10–12. Alternatively, the framework could comprise four struts, in which case the struts would extend radially at 90 degrees from one another. *Id.* at 5:22–27. Suture pads 18, 20, and 22 are attached to the extremities of the struts. *Id.* at 4:15–17. The struts may comprise a resilient or a springy material that is nonthrombogenic. *Id.* at 4:22–25.

Figure 2 shows flexible membrane 30 attached to the framework. *Id.* at 4:49–51. Membrane 30 has a hemispheric or paraboloid shape that fits within the framework and is attached to struts 10, 12, and 14 at all points extending from point 16 to suture pads 18, 20, and 22. *Id.* at 4:57–63. Thus,

the dynamic annulus heart valve depicted in FIG. 2 constitutes a flexible central frame to which the flexible membrane is attached to form at least three valve leaflets which expand outwardly in the reverse direction of flow of blood to block passage of blood through a valve annulus and which contract inwardly against one another to allow forward flow of blood.

Id. at 5:12–19.

Figure 7 of Johnson is reproduced below.

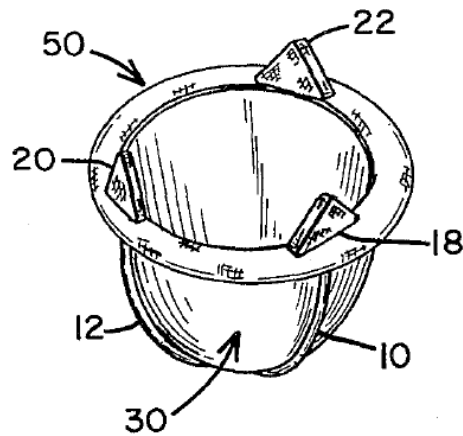

Fig. 7

Figure 7 shows the dynamic annulus heart valve with reconstruction ring 50. *Id.* at 6:8–10. Reconstruction ring 50 comprises inner doughnut shaped body 52 made of a relaxed and pliant silicone rubber and fabric sleeve 54 surrounding body 52. *Id.* at 5:57–61, Fig. 6. Reconstruction ring 50 is sutured in place to the remaining heart tissue, whereby tissue ingrowth into fabric sleeve 54 will take place over time. *Id.* at 5:62–68.

2. *Overview of Imachi*

Imachi “relates to a medical valve apparatus comprising a valve seat and a movable valve membrane, which is valuable, for example, as an artificial valve apparatus of a pulsatile artificial heart or a pulsatile artificial heart-lung machine.” Ex. 1020, 1:9–13. In one embodiment, Imachi discloses a medical valve apparatus having funnel-shaped valve seat 8 with holes 9 and movable valve membrane 7 having a funnel-like shape conforming to valve seat 8. *Id.* at 3:49–60; Figs. 3A–3C.

3. *The Proposed Combination*

Petitioner argues that it would have been obvious “to mount a durable synthetic funnel valve of Johnson within the stent of Bessler to produce a durable, collapsible, transcatheter replacement heart valve.” Pet. 49 (citing Ex. 1003 ¶¶ 108–112). Petitioner provides a drawing, labelled “Fig. H” and reproduced below, purporting to represent the structure resulting from the proposed combination.

FIG.H

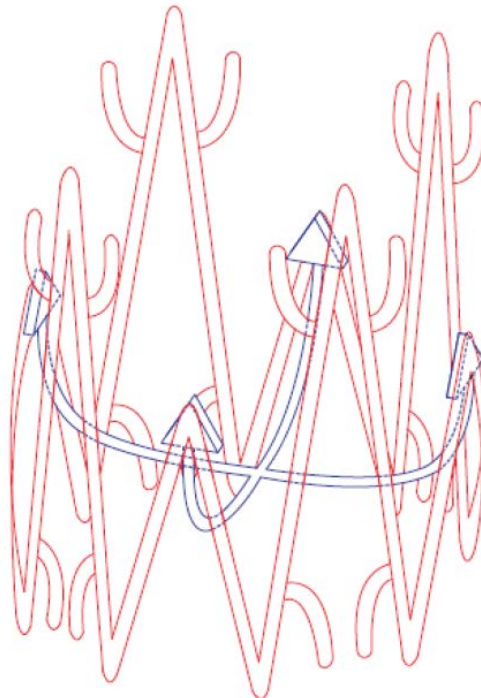

Id. Figure H depicts the funnel valve of Johnson disposed inside the stent of Bessler. Petitioner relies on Imachi as an alternative teaching to omit the intermediate attachments between Johnson’s flexible membrane 30 and struts 10, 12, and 14. *Id.* at 60–62.

4. *Reasons for Combining*

As one reason for combining Bessler and Johnson, Petitioner asserts at the time the '782 patent was filed, "there was already a movement toward transcatheter heart valves to avoid invasive open heart surgery." *Id.* at 47 (citing Ex. 1003 ¶¶ 25, 105). Petitioner also asserts that one of ordinary skill in the art would have known "know that the patients most in need of transcatheter procedures are the frailest," and "[n]ot only is open chest surgery to be avoided, but even subsequent transcatheter procedures should be avoided where possible." *Id.* at 48 (citing Ex. 1003 ¶ 107). Next, Petitioner argues that Johnson discloses a collapsible and durable valve, but does not provide for transcatheter implantation because it discloses only sutures for fixation. *Id.* (citing Ex. 1021, 2:39–42, 3:37–47, 4:22–25; Ex. 1003 ¶ 107). Petitioner then argues that Bessler recognizes that a self-expanding stent can be used to securely hold a valve in place in a heart annulus. *Id.* at 48–49. Petitioner concludes that "there is reason to mount a durable synthetic funnel valve of Johnson within the stent of Bessler to produce a durable, collapsible, transcatheter replacement heart valve." *Id.* at 49 (citing Ex. 1003 ¶¶ 108–112). We agree with this reasoning because Petitioner shows that one of ordinary skill in the art would recognize the benefit of a transcatheter valve eliminating the need for open chest surgery and modifying Johnson's valve to include the stent of Bessler allows the valve to be delivered via catheter.

Patent Owner disputes this assertion, arguing that one of ordinary skill in the art would not have been motivated to combine teachings of Bessler and Johnson and that the proposed combination is based upon impermissible

hindsight. PO Resp. 38 (citing Ex. 2026 § 3.1.3.1). In particular, Patent Owner argues “Petitioner’s proposed combination is not replacing one valve for another valve or one frame for another frame. Rather, Petitioner proposes to place the *entire non-collapsible frame and valve* of one reference (Johnson) *inside* the collapsible frame of another reference (Bessler).” *Id.* at 39. This argument is not persuasive because Petitioner’s reason for combining the references, as discussed above, does not rely on the modification being the mere substitution of one element for another known in the field.

Patent Owner also argues that the proposed combination would increase the collapsible diameter of the valve, rendering it too large for transluminal delivery. *Id.* at 40 (citing Ex. 1009, 2127–29; Ex. Ex. 2026 § 3.1.3.1). We disagree with this argument because Johnson’s strut-based frame and membrane are both flexible and very thin. Johnson’s flexible struts are 0.030 inches (0.76 mm) in diameter and its membrane 30 is no more than 0.003 inches (0.08 mm) thick. Ex. 1021, 4:37–53. Struts 10, 12, 14 are formed of “a resilient or a springy material which is nonthrombogenic such as titanium or polytetrafluoroethylene or Teflon® polymer.” *Id.* at 4:22–25. Bessler’s stent is made of wire of only about 0.012–0.035 inches (0.30–0.89 mm). Ex. 1008, 6:11–12. Bessler’s stent collapses into a very small cylinder such that little space remains between its wire frame. *Id.* at 5:44–46, Figure 5. Given the stated, sub-millimeter sizes of all the relevant components of Johnson and Bessler, we see no reason why Johnson’s strut-based frame and membrane combined with Bessler’s stent

would not easily collapse into a configuration narrow enough for transluminal delivery.

In addition, the only objective evidence cited by Patent Owner, Ex. 1009, 21:27–29, fails to support the proposition that the Johnson’s valve within Bessler’s stent would be “too large for transluminal delivery.” The cited passage reads: “The presence of the internal cover makes an additional layer of plastic material that occupies the inside of the frame and increases the final size of the IV [implantable valve]³.” At most, this passage demonstrates that adding more material to an implantable valve increases its diameter. The implantable valve being discussed is designed to replace an aortic valve, includes a stent structure made from bars 0.1–0.6 mm in diameter, and compresses to a diameter of 4–5 mm. Ex. 1009, 14:23–16.

For all these reasons, Dr. Chronos’s testimony that the incorporation of Johnson’s strut-based frame and membrane into Bessler’s stent renders the combined structure too large is not supported by the objective evidence of record. Patent Owner’s argument rests upon Dr. Chronos’s testimony. Accordingly, we find Patent Owner’s argument unpersuasive.

5. *Claims 1, 10–13, 18, 19, 21, 22, and 25–28*

Independent claims 1 and 28 both recite an artificial valve for repairing a damaged heart valve comprising a flexibly resilient frame having a plurality of peripheral anchors and “a band attached to the frame limiting spacing between adjacent anchors of said plurality of peripheral anchors.” Ex. 1001, 10:22–34, 13:66–14:17. Independent claim 10 recites an artificial

³ Ex. 1009, 1:12–13.

valve for repairing a damaged heart valve comprising a flexibly resilient frame having a plurality of peripheral anchors and “a band comprising an internal strip positioned inside and attached to the frame limiting spacing between adjacent anchors of said plurality of peripheral anchors.” *Id.* at 11:26–37. Independent claim 18 recites an artificial valve for repairing a damaged heart valve comprising a plurality of U-shaped frame elements and “a band surrounding the frame and extending between adjacent elements of said plurality of frame elements to limit spacing between said adjacent elements.”⁴ *Id.* at 12:55–67.

For each of these claims, Petitioner argues the recited band is satisfied by either the cuff of Bessler or Johnson’s reconstruction ring 50. Pet. 55–56 (citing Ex. 1008, 3:54–64, 4:4–11, 5:24–27, Figs. 1–5, 7; Ex. 1021, 5:54–6:14, Figs. 6, 7; Ex. 1003 ¶¶ 66–70, 123–125). As for the requirement that the band limit spacing, Petitioner argues Bessler’s cuff is shown tight against the self-expanding stent and one of ordinary skill in the art would expect the cuff to restrict expansion of the stent. *Id.* at 56 (citing Ex. 1008, 5:15–27, 5:40–42, Figs. 1, 4; Ex. 1003 ¶¶ 70, 126).

We find these arguments unpersuasive. First, we disagree that when Johnson and Bessler are combined in the manner proposed by Petitioner, the resulting structure would include Bessler’s cuff. As noted above, Petitioner proposes to mount Johnson’s valve within Bessler’s stent; in other words, Bessler’s valve is replaced with Johnson’s valve. *Id.* at 49. Bessler

⁴ Claim 18 does not recite a frame as antecedent for “the frame.” For purposes of this Decision, we consider “the frame” to refer to the U-shaped frame elements collectively.

discloses that cuff portion 25 extends from the periphery of circular portion 27 of flexible valve means 22. Ex. 1008, 5:24–26, Fig. 1. Bessler also discloses that cuff portion 37 extends from the periphery of the leaflet portion of valve member 35. *Id.* at 5:36–39, Fig. 4. Thus, in both embodiments, the cuff is an integral portion of the valve member. Petitioner does not explain adequately why one of ordinary skill in the art, when replacing Bessler’s valve with Johnson’s valve would remove the leaflet portion of Bessler’s valve but retain the cuff portion. Bessler makes clear that the purpose of the cuff portion for attaching the valve to the stent. *Id.* at 5:26–27, 5:41–42. Once the leaflet portion of Bessler’s valve is removed, the cuff serves no purpose. For these reasons, we are not persuaded that an ordinarily skilled artisan making the combination proposed by Petitioner would retain Bessler’s cuff, meaning the cuff could not satisfy the requirement for a band.

Second, to the extent Johnson’s reconstruction ring 50 is a band, Petitioner does not explain adequately how ring 50 would limit spacing as required by claims 1, 10, 18, and 28. In fact, Petitioner does not even assert that Johnson’s reconstruction ring 50 limits spacing.

For these reasons, we determine that Petitioner has not shown, by a preponderance of the evidence, that independent claims 1, 10, 18, and 28 are unpatentable in view of the combination of Johnson and Bessler. Also, Petitioner has not shown, by a preponderance of the evidence, that claims 11–13, depending from claim 10, and claims 19, 21, 22, and 25–27, depending from claim 18, are unpatentable in view of the combination of Johnson and Bessler.

6. *Claims 17 and 30*

Independent claim 17 recites a first band surrounding and attached to a frame and a second band surrounding and attached to the frame downstream of the first band. Ex. 1001, 12:26–30. Independent claim 30 a first band surrounding a frame and a second band surrounding the frame downstream of the first band. *Id.* at 1001, 16:3–13.

Petitioner argues that Bessler meets these limitations for the reasons asserted in connection with the ground asserting the claims are anticipated by Bessler. For the reasons discussed above, however, we determine that Petitioner does not establish adequately that Bessler discloses first and second bands. *See supra* § III.D.9. Accordingly, for at least the foregoing reasons, Petitioner has not shown, by a preponderance of the evidence, that independent claims 17 and 30 are unpatentable in view of the combination of Johnson and Bessler.

7. *Claim 29*

Independent claim 29 recites an artificial valve for repairing a damaged heart valve in combination with an instrument for inserting the artificial valve in a patient. Ex. 1001, 14:57–62. Claim 29 recites that the instrument includes the same elements recited in claim 28. *Id.* at 15:33–16:2. Petitioner argues that “Bessler describes just such an instrument as previously discussed in Ground 1.” Pet. 63. For the reasons discussed above, however, we determine that Petitioner does not establish adequately that Bessler discloses all the elements of the instrument. *See supra* § III.D.8. Accordingly, for at least the foregoing reasons, Petitioner

has not shown, by a preponderance of the evidence, that independent claim 29 is unpatentable in view of the combination of Johnson and Bessler.

G. Asserted Obviousness over Bessler, Johnson, and Imachi

Petitioner contends claims 1, 2, 4–8, 10–13, 17–19, 21, 22, and 25–30 would have been obvious over Bessler, Johnson, and Imachi. Pet. 67–69. Patent Owner disputes Patent Owner’s contentions. PO Resp. 38–45.

For this ground, Petitioner argues:

The teachings of Bessler, Johnson, and Imachi, as described in Ground 3, are equally applicable here. Johnson can be used as a principal reference for the reasons discussed in Ground 3, namely converting a surgical valve with desirable properties to a transcatheter valve by mounting it in a collapsible, flexibly resilient stent already used for such purposes. However, the combination could be viewed in the opposite direction.

Pet. 67. Petitioner also argues “[t]he manner in which the elements of Bessler, Johnson, and Imachi would be combined is identical to that explained in Ground 3.” *Id.* at 69.

Given that Petitioner asserts that the references are combined in the same matter, we determine that simply changing which reference is considered the “principal reference” does not overcome the deficiencies of the combination of Johnson and Bessler discussed above. *See supra* §§ III.F.5–III.F.8. Accordingly, we determine that Petitioner has not shown, by a preponderance of the evidence, that the challenged claims are unpatentable in view of the combination of Bessler, Johnson, and Imachi.

H. Secondary Considerations

Patent Owner argues that numerous objective indications of the non-obviousness, such as peer recognition, long-felt but unresolved need,

commercial success, and acceptance and adoption by industry, exist and weigh heavily against deeming the invention of the '782 patent obvious. PO Resp. 45–50. Because we are not persuaded Petitioner has demonstrated sufficiently that the combinations of (1) Bessler and Andersen; (2) Johnson, Bessler, and Imachi; and (3) Bessler, Johnson, and Imachi render the challenged claims obvious, we need not reach Patent Owner's assertions regarding secondary considerations.

I. Constitutional Issue

Patent Owner objects to *inter partes* review “because it is carried out by a final order issued by Administrative Patent Judges who have not been nominated by the President and confirmed by the Senate.” PO Resp. 51. According to Patent Owner, Administrative Patent Judges are “principal Officers” under the Constitution's Appointments Clause (U.S. Const. Art. II, § 2, Cl. 2), meaning they must be nominated by the President and confirmed by the Senate in order to exercise their authority constitutionally with respect to *inter partes* reviews. *Id.*

Patent Owner, however, does not direct us to any authority holding that Administrative Patent Judges are principal Officers under the Appointments Clause. Furthermore, in 2008, Congress changed the law to provide that Administrative Patent Judges be appointed by the Secretary of Commerce in consultation with the Director. Pub. L. 110–313, 122 Stat 3014 (Aug.12, 2008). Accordingly, we are not persuaded that Administrative Patent Judges conducting *inter partes* reviews is unconstitutional.

J. Motion to Exclude Evidence and Motion to Strike

Petitioner's Motion to Exclude Evidence seeks to exclude from Patent Owner's Sur-Reply the sentence at lines 11–13 on page 4, as well as the corresponding figure provided after this sentence. Mot. to Exclude 1. Petitioner argues this sentence and the figure should be excluded under Federal Rules of Evidence (FRE) 802 as impermissible hearsay, under FRE 402 as irrelevant, and under FRE 702 because there is no showing the author has the requisite scientific, technical, or other specialized knowledge. *Id.* at 2–4. Petitioner also argues the sentence and its corresponding figure should be excluded under 37 C.F.R. § 42.63(a). *Id.* at 5. Patent Owner disputes these arguments. Opp. Mot. to Exclude 3–6.

We do not rely, however, on these sentence or the corresponding figure in rendering our decision. Therefore, we *dismiss* Petitioner's Motion to Exclude Evidence as moot.

Petitioner's Motion to Strike requests the Board to strike the same material from Patent Owner's Sur-Reply, as well as the sentence beginning at line 3 on page 3 of the Sur-Reply. Mot. To Strike 1. Because we do not rely on any of this material in rendering our decision, we *dismiss* Petitioner's Motion to Strike as moot.

IV. ORDER

In consideration of the foregoing, it is hereby:

ORDERED that claims 1, 2, 6, and 8 of the '782 patent have been shown to be *unpatentable*;

FURTHER ORDERED that claims 4, 5, 7, 10–13, 17–19, 21, 22, and 25–30 of the '782 patent have not been shown to be *unpatentable*;

FURTHER ORDERED that Petitioner's Motion to Exclude Evidence (Paper 45) is *dismissed* as moot;

FURTHER ORDERED that Petitioner's Motion to Strike (Paper 46) is *dismissed* as moot;

FURTHER ORDERED that, because this is a Final Written Decision, parties to the proceeding seeking judicial review of the decision must comply with the notice and service requirements of 37 C.F.R. § 90.2.

IPR2018-00106
Patent 6,540,782 B1

For PETITIONER:

Ted Van Buskirk
Michael Teschner
Stephen Lund
Jordan Riviello
LERNER DAVID LITTENBERG KRUMHOLZ & MENTLIK LLP
tvanbuskirk@ldlkm.com
mteschner.ipr@ldlkm.com
slund@lernerdavid.com
jriviello@ldlkm.com

For PATENT OWNER:

Matthew Antonelli
Zachariah Harrington
Larry Thompson
ANTONELLI, HARRINGTON & THOMPSON LLP
matt@ahtlawfirm.com
zac@ahtlawfirm.com
larry@ahtlawfirm.com