



US008834457B2

(12) **United States Patent**
Cao

(10) **Patent No.:** **US 8,834,457 B2**
(45) **Date of Patent:** **Sep. 16, 2014**

(54) **MODULAR SURGICAL LASER SYSTEMS**

(75) Inventor: **Densen Cao**, Sandy, UT (US)

(73) Assignee: **CAO Group, Inc.**, West Jordan, UT (US)

(*) Notice: Subject to any disclaimer, the term of this patent is extended or adjusted under 35 U.S.C. 154(b) by 1364 days.

(21) Appl. No.: **12/035,422**

(22) Filed: **Feb. 21, 2008**

(65) **Prior Publication Data**

US 2008/0154249 A1 Jun. 26, 2008

Related U.S. Application Data

(63) Continuation-in-part of application No. 10/947,055, filed on Sep. 22, 2004, now Pat. No. 7,485,116.

(60) Provisional application No. 60/891,037, filed on Feb. 21, 2007.

(51) **Int. Cl.**

A61B 18/18 (2006.01)
G02B 6/36 (2006.01)
A61B 18/22 (2006.01)
A61B 18/20 (2006.01)
A61N 5/06 (2006.01)

(52) **U.S. Cl.**

CPC **A61B 18/22** (2013.01); **A61B 18/20** (2013.01); **A61N 2005/063** (2013.01); **A61B 2018/2205** (2013.01); **A61B 2018/2065** (2013.01)
USPC **606/15**; 385/88

(58) **Field of Classification Search**

USPC 606/9, 15; 385/88, 134, 135
See application file for complete search history.

(56) **References Cited**

U.S. PATENT DOCUMENTS

5,127,068 A 6/1992 Baer et al.
5,420,882 A 5/1995 Black
6,061,371 A 5/2000 Uejima et al.
6,129,721 A 10/2000 Kataoka et al.
6,364,540 B2* 4/2002 Shishikura et al. 385/88
2005/0203496 A1* 9/2005 Ritchie et al. 606/15

OTHER PUBLICATIONS

Third Party Requester's Comments in U.S. Appl. No. 95/002,271 (Interparties Reexam) on Feb. 15, 2013.
Office Action issued in U.S. Appl. No. 95/002,271 (Interparties Reexam) on Apr. 23, 2013.
Biolase User Manual, The Complete Laser for Every Dentist, Biolase Technology Inc, Copyright 2000-2003.
Bloomberg Law Document, PR Newswire, Feb. 26, 2002, Biolase Receives First Ever FDA Clearance for Laser Cutting, Shaving, Contouring and Resection or Oral Osseous Tissues (Bone).

(Continued)

Primary Examiner — Melanie Hand

(74) *Attorney, Agent, or Firm* — CAO Group, Inc.; Terry S. Jones

(57) **ABSTRACT**

Laser emission systems for surgical and other therapeutic uses are herein disclosed. In the preferred embodiments, different laser control systems are disclosed and disposable tips and fiber with a unique connection structure are utilized. By being disposable, the tips are manufactured to minimize material loss while also providing the confidence patients desire for their health which comes from knowing the tips are sterile. One end of the fiber is encased in a ferrule, which provides the permanent connection. A lens structure may also be utilized to focus laser light as it passes from a waveguide into the tip. The laser generation module may emit laser light in multiple wavelengths simultaneously and may also feature remote operation.

8 Claims, 17 Drawing Sheets

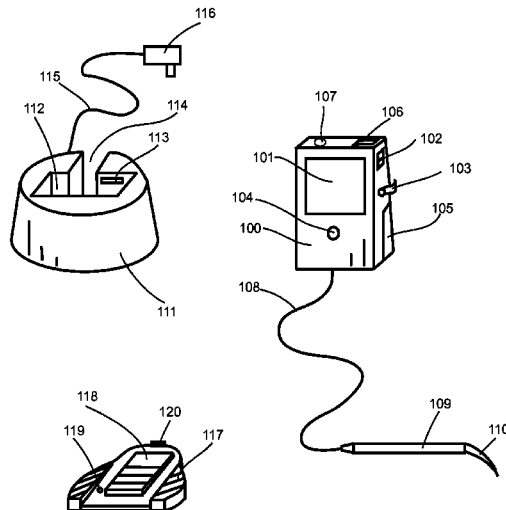

(56)

References Cited

OTHER PUBLICATIONS

Crosby, Sean C., Optical Coherence Tomography, The University of Melbourne, Australia, 2003, pp. 1-36.

Lucent Technologies, Bell Labs Innovations, A2300-Type Laser 2000, Analog DFB Laser Module, Data Sheet Mar. 1999.

Synrad, Synrad DC-36 DC Power Supply (Power-One HPF5), PIN 900-18689-02, Rev Jan. 2003.

Waynant, Ronald W., Lasers in Medicine, 2002 by CRC Press LLC. Wirbelauer et al., Experimental Evaluation of Online Optical Coherence Pachymetry for Corneal Refractive Surgery, Published online Nov. 14, 2003, pp. 1-30.

* cited by examiner

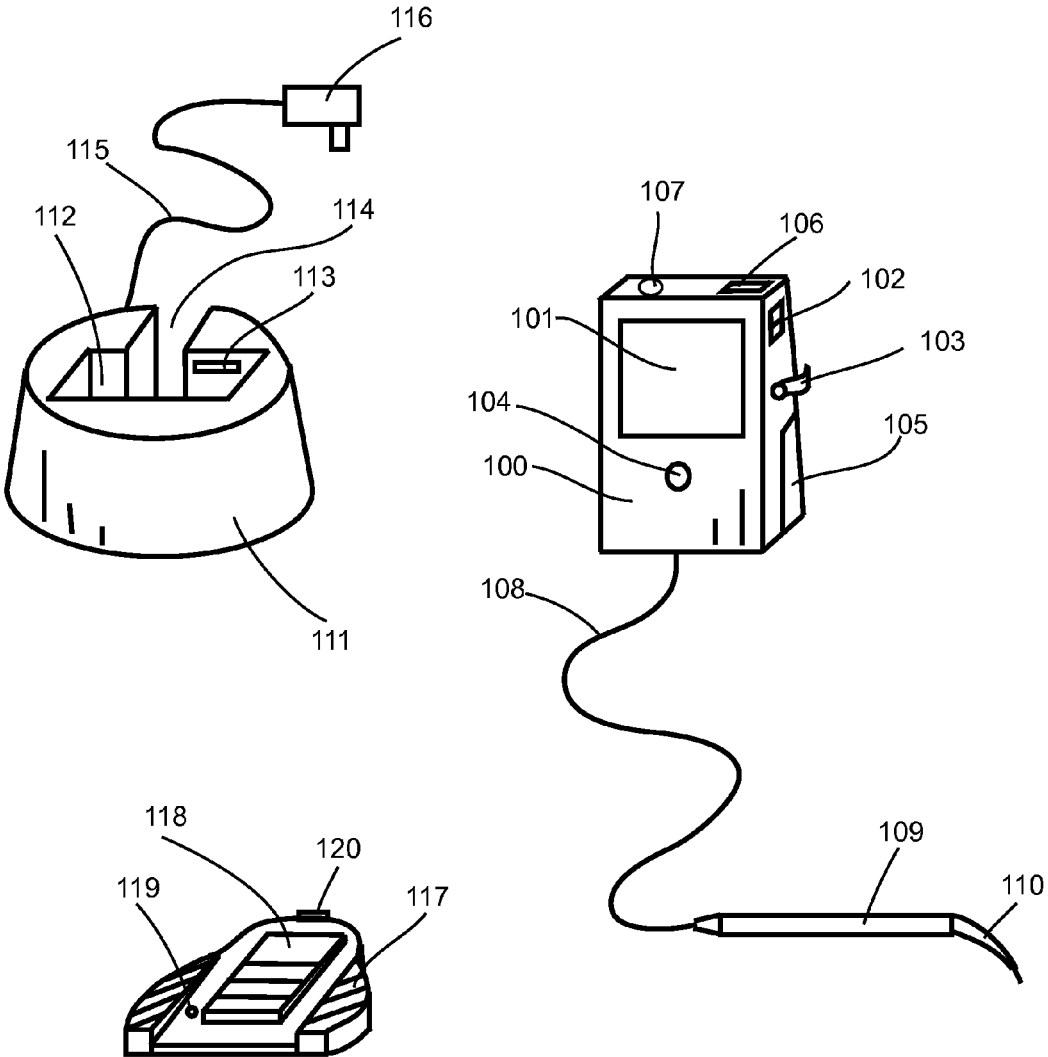

Figure 1

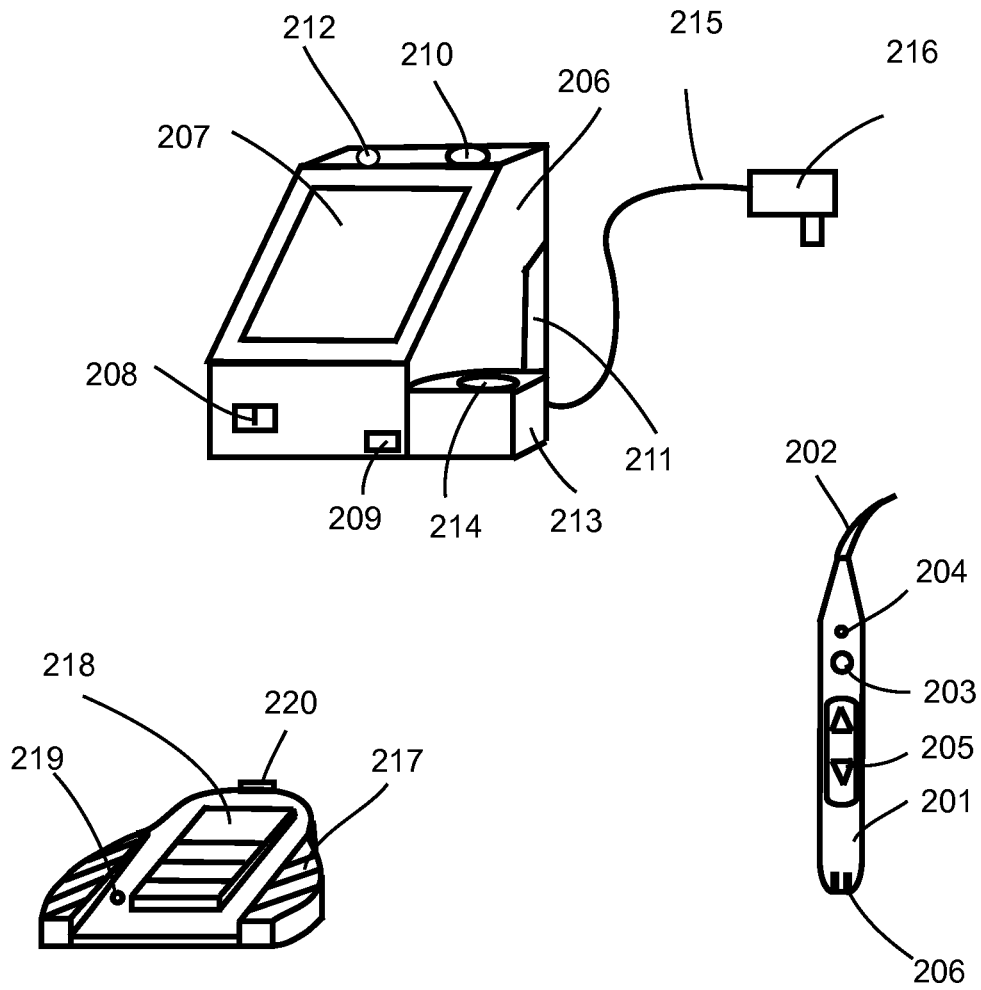
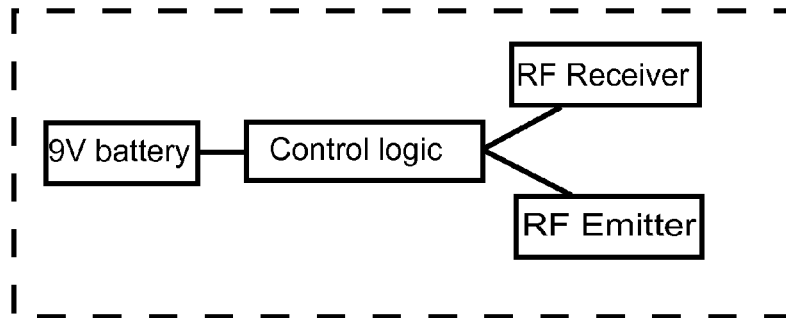
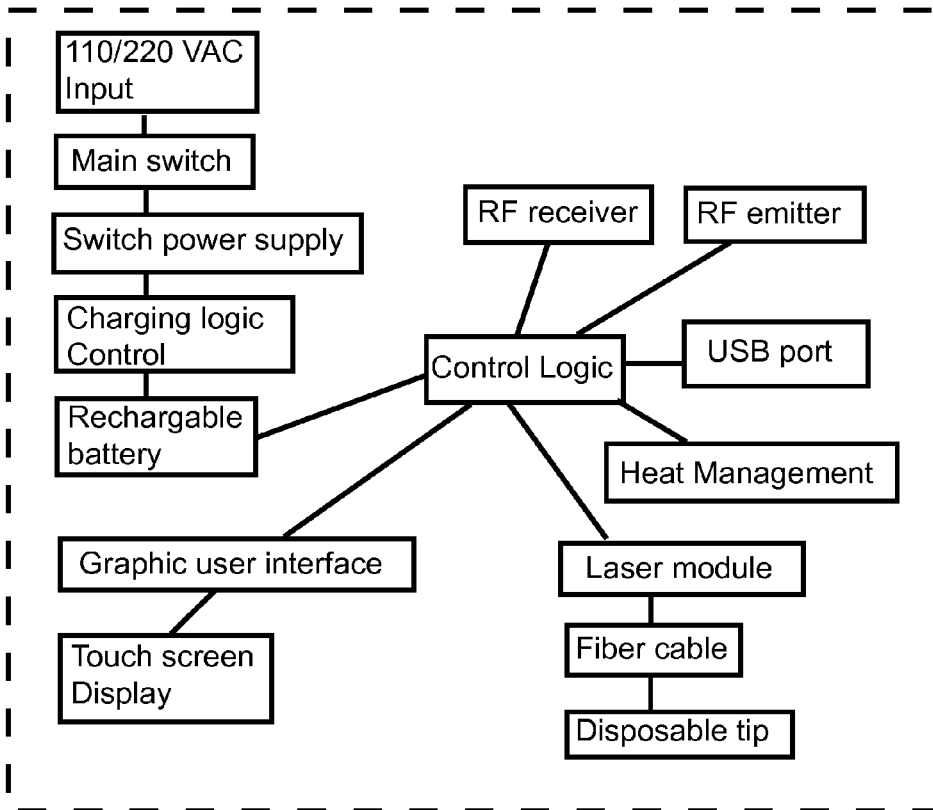

Figure 2



(a)



(b)

Figure 3

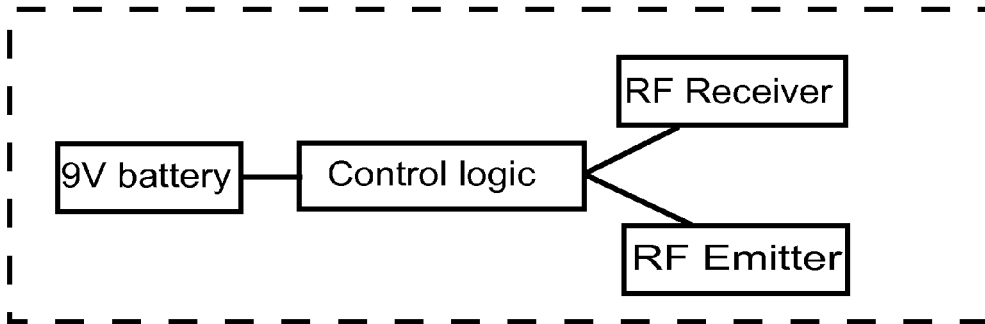

(a)

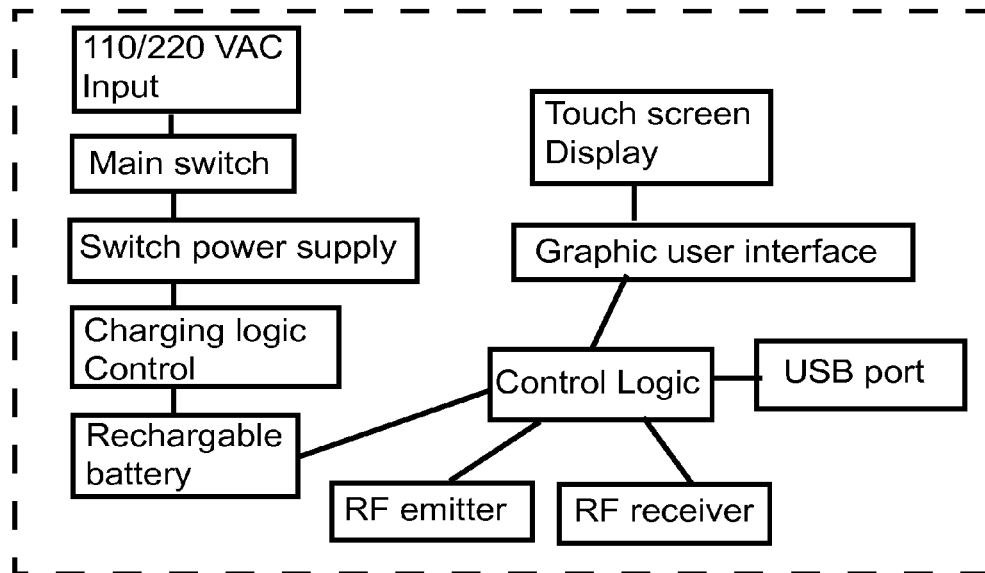

(b)

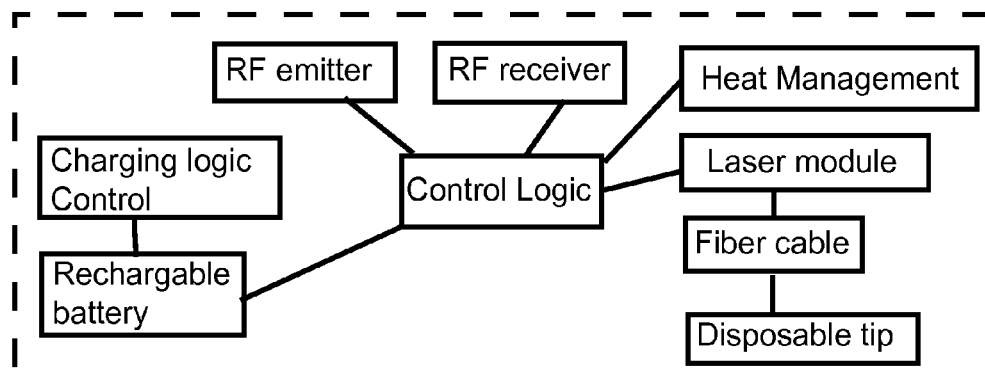

(c)

Figure 4

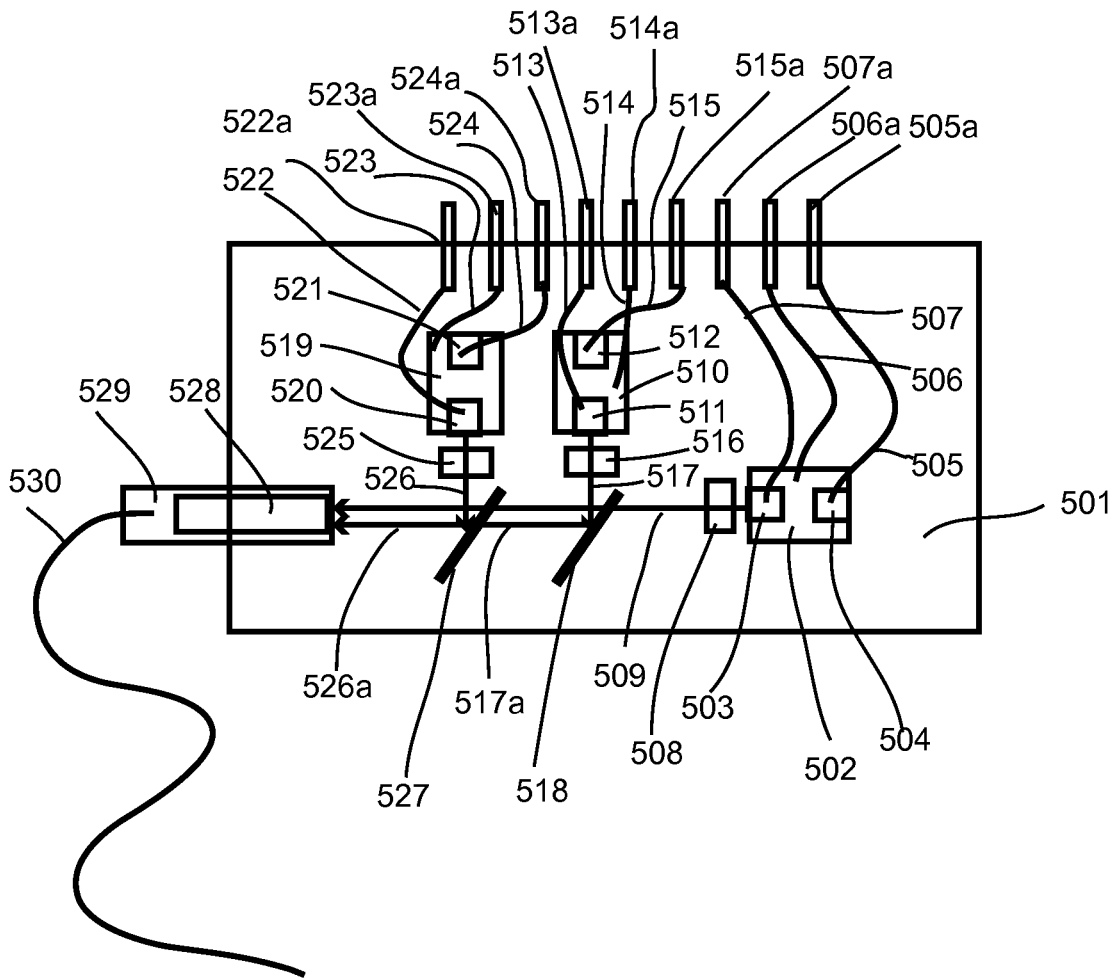

Figure 5

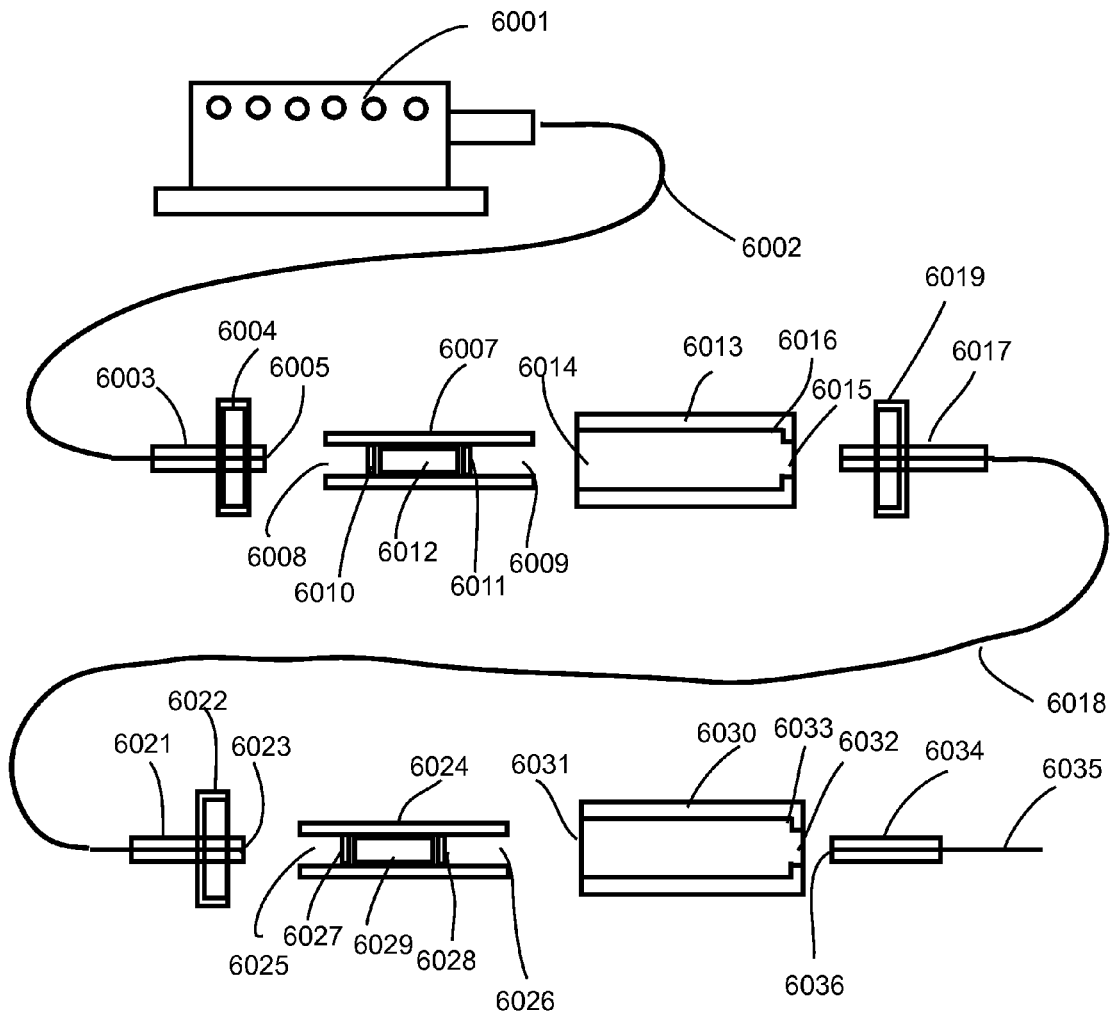

Figure 6(a)

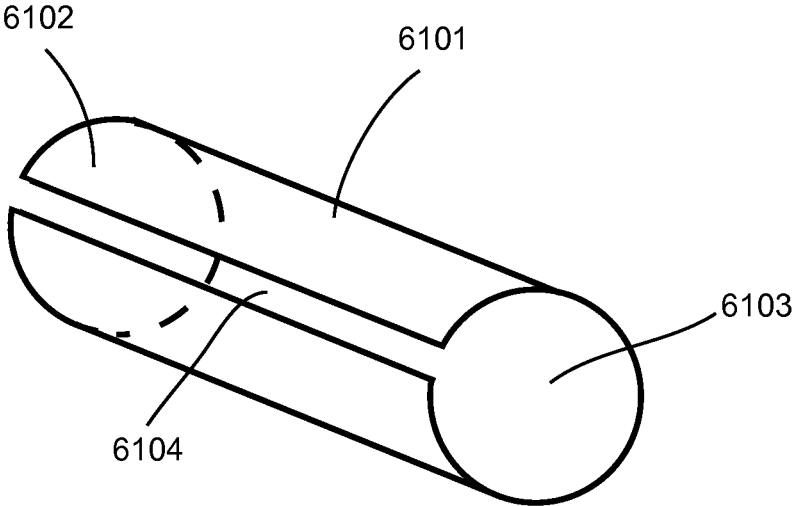

Figure 6(b)

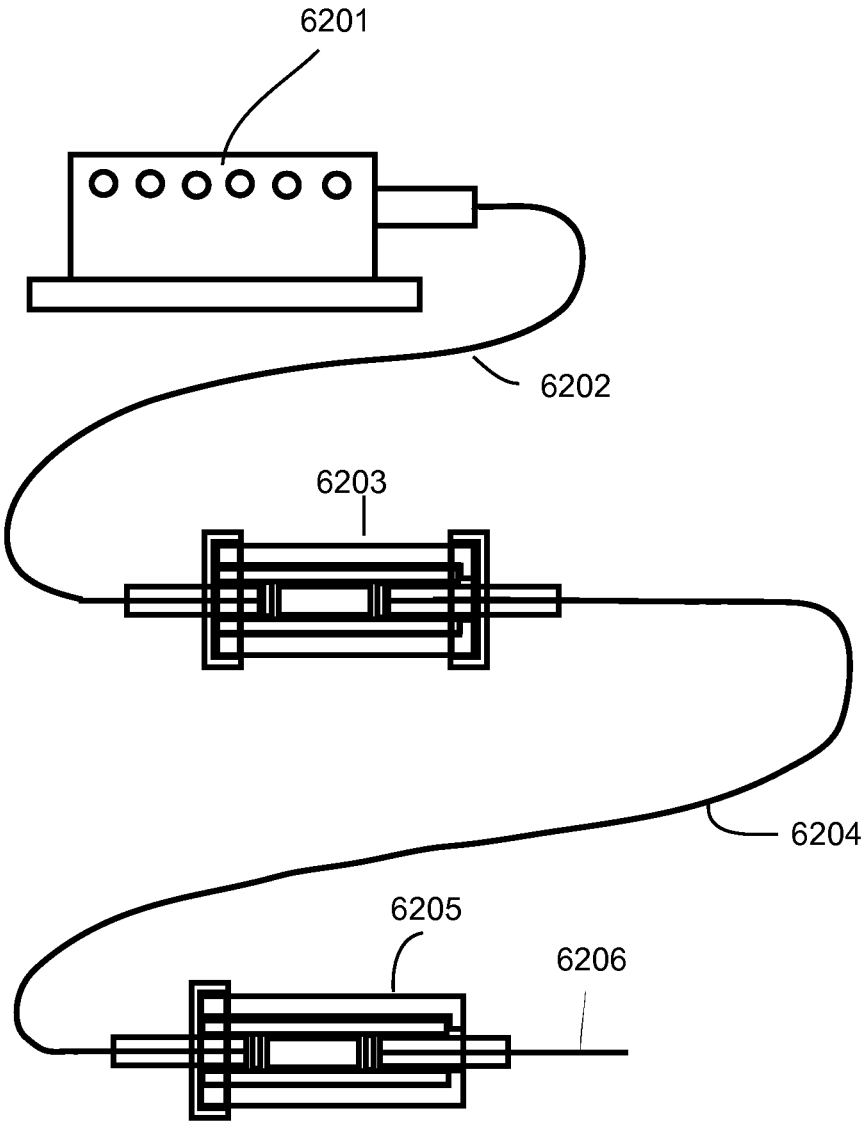

Figure 6(c)

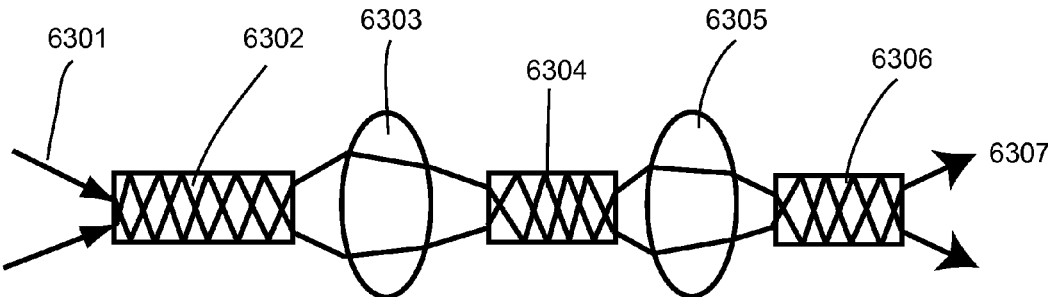

Fig 6(d)

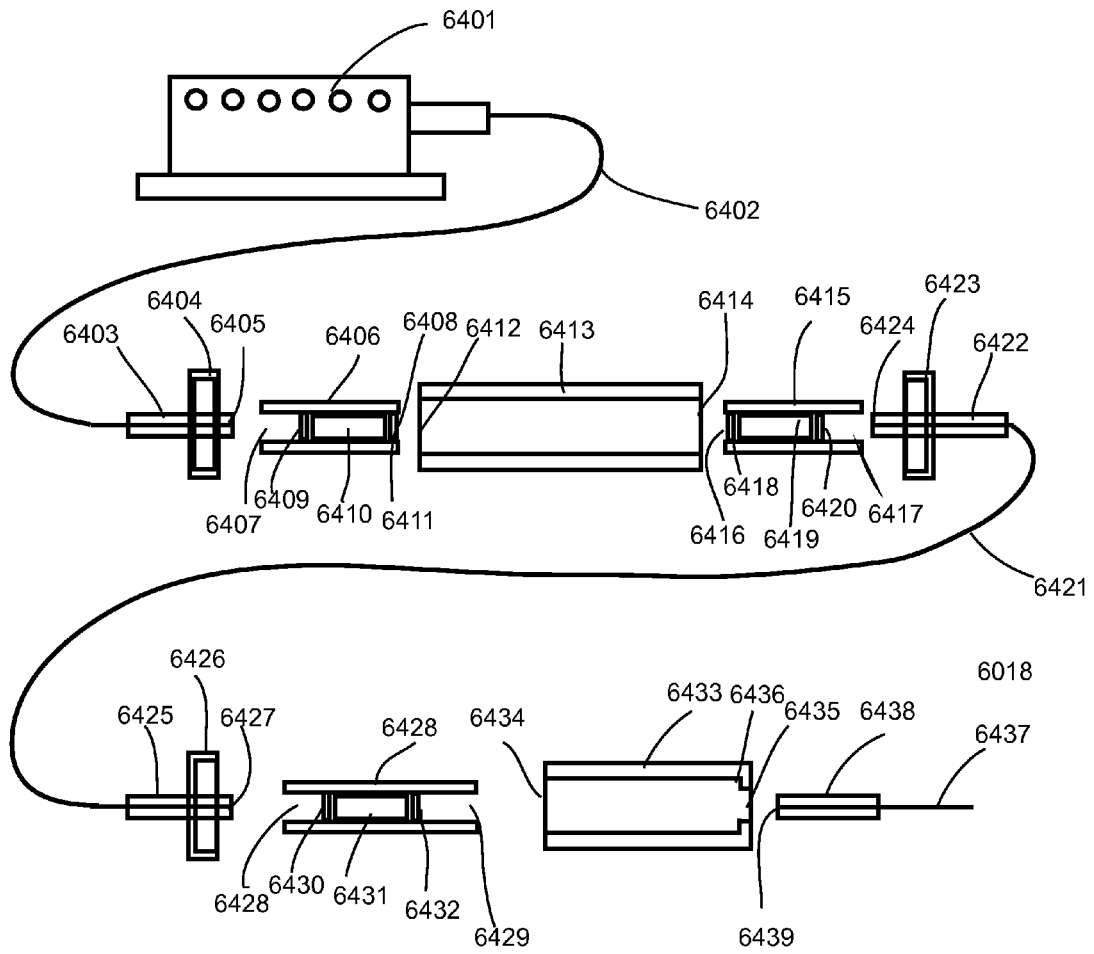

Figure 6(e)

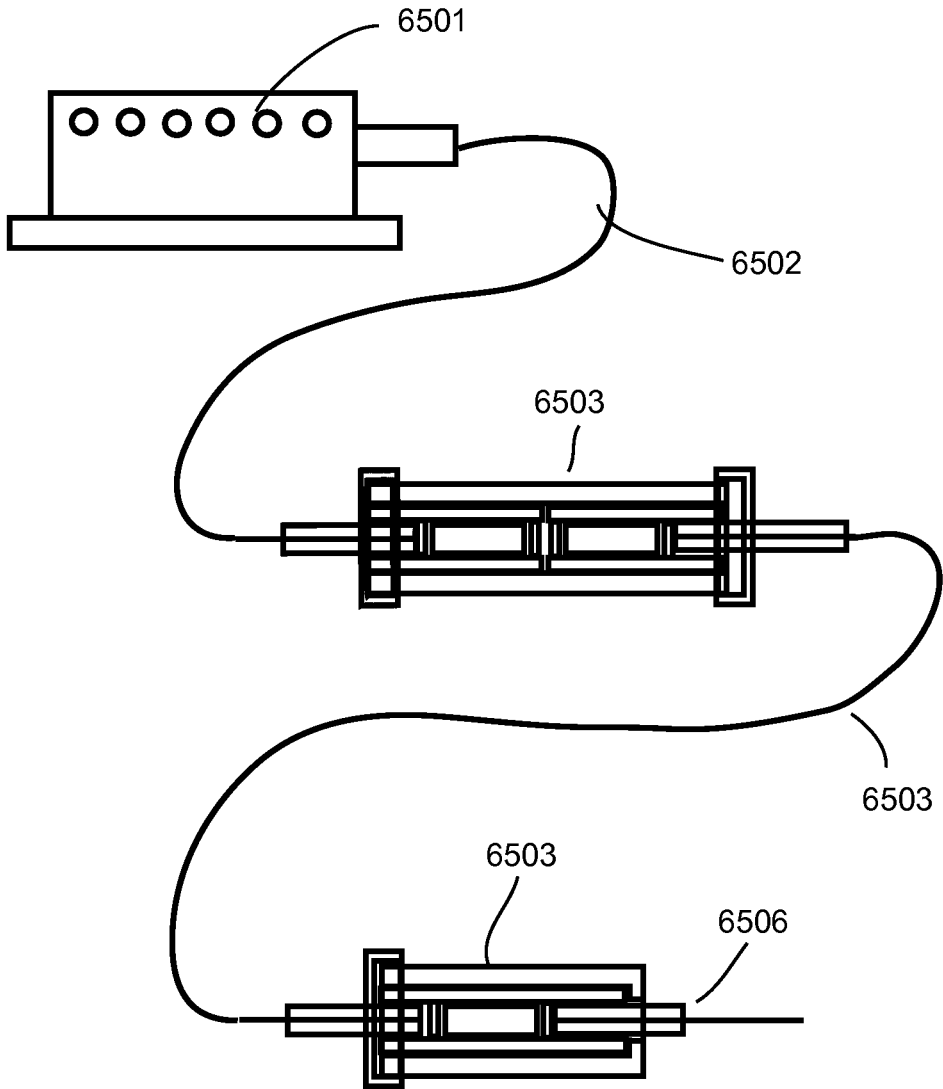

Figure 6(f)

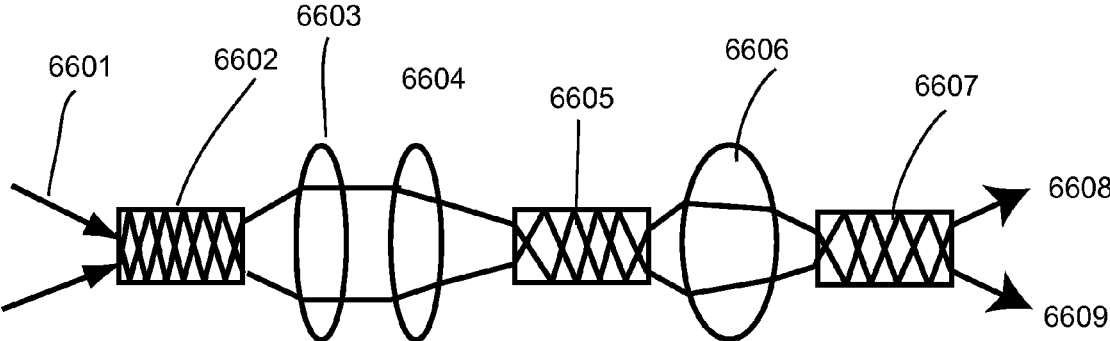

Fig 6(g)

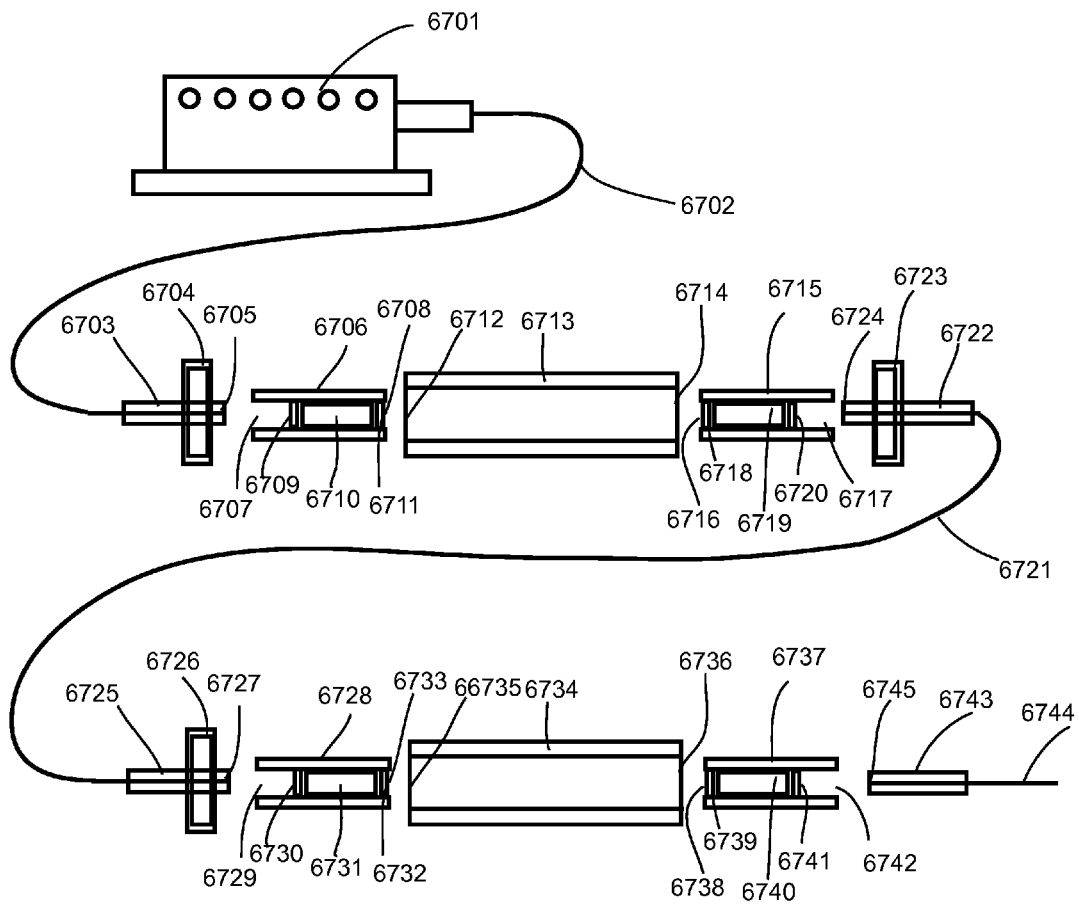

Figure 6(h)

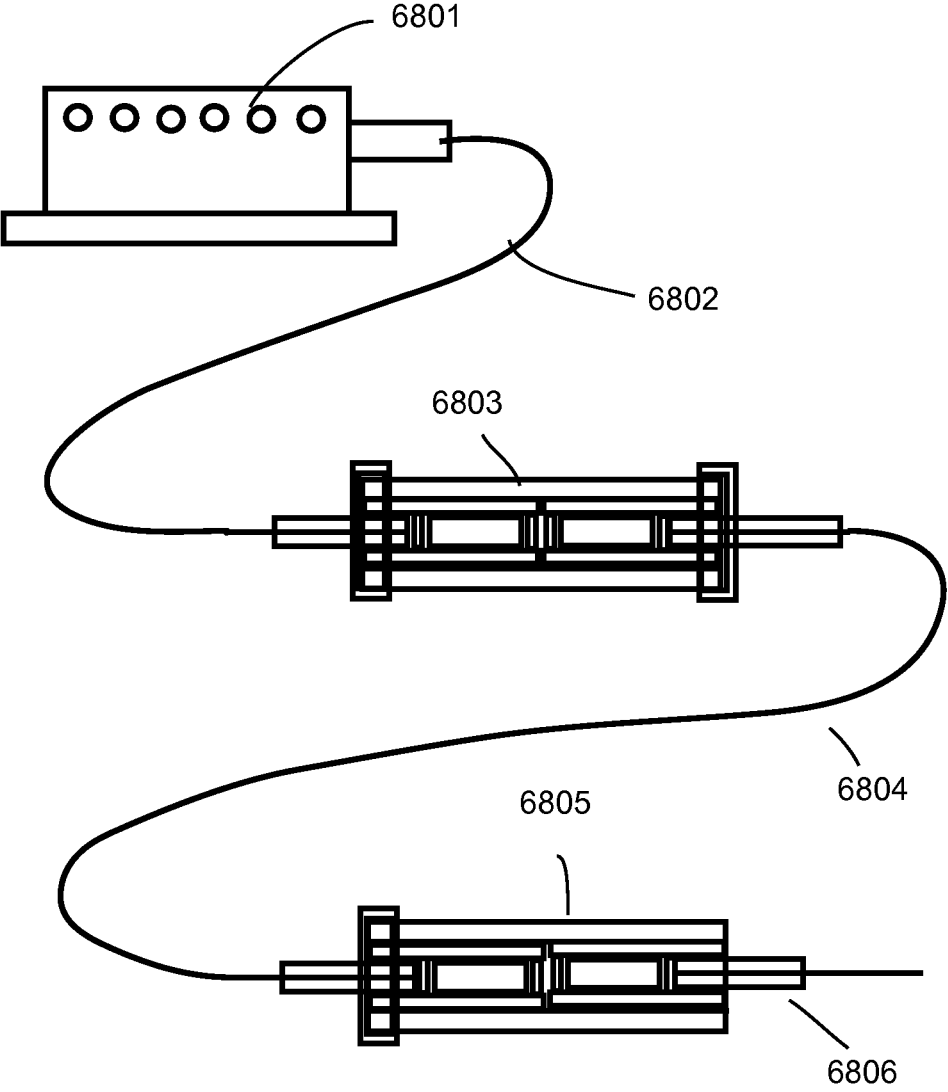

Figure 6(i)

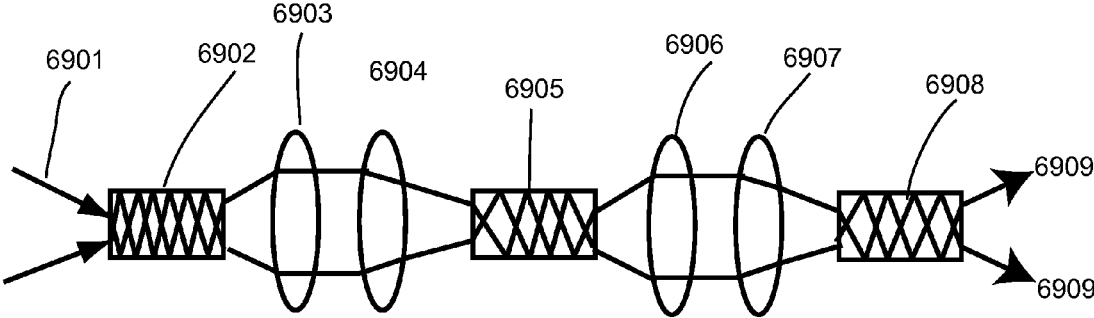

Fig 6(j)

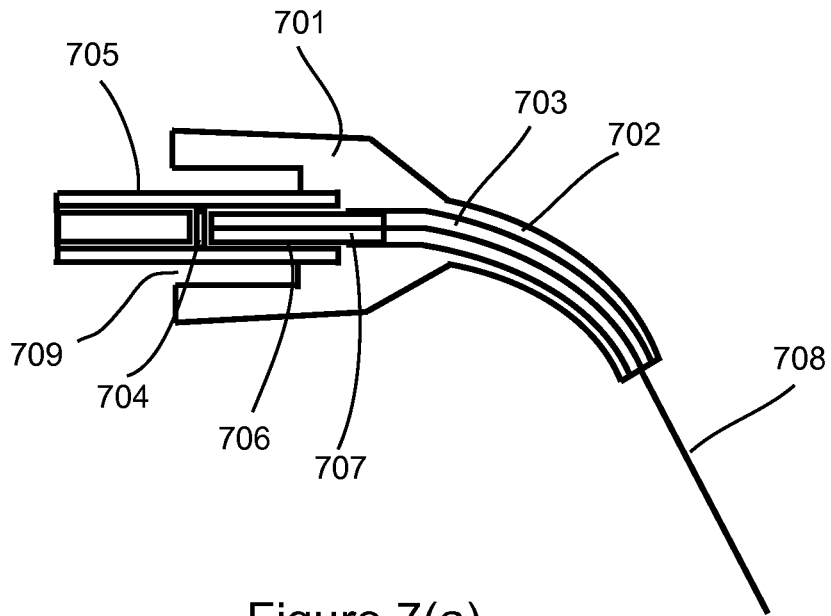

Figure 7(a)

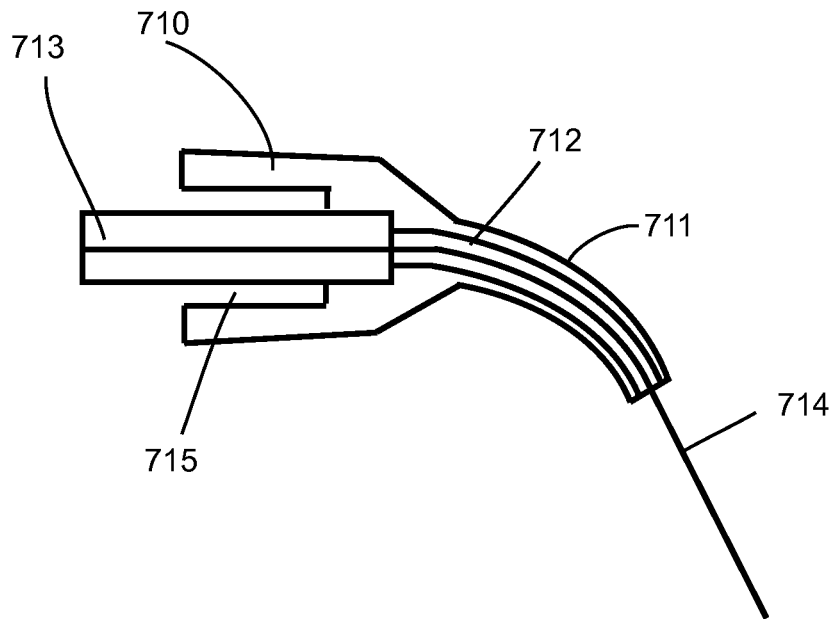

Figure 7(b)

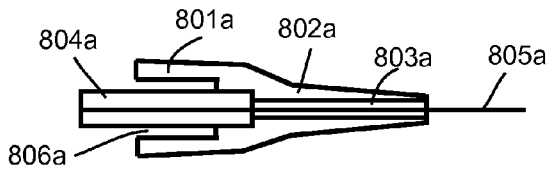

Fig. 8a. 0 degree tip

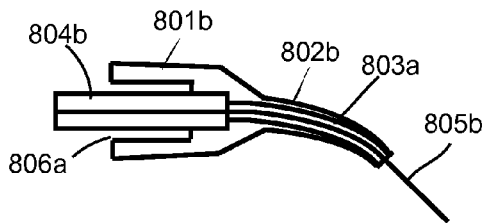

Fig. 8b. 30 degree tip

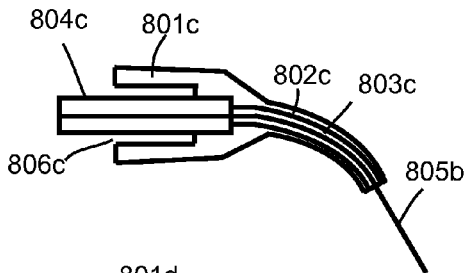

Fig. 8c. 45 Degree tip

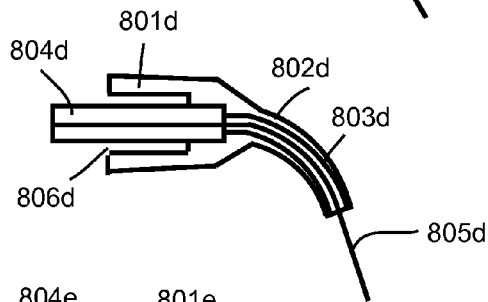

Fig. 8d. 60 Degree tip

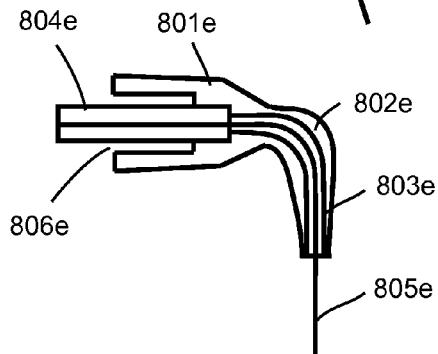

Fig. 8e. 90 Degree tip

MODULAR SURGICAL LASER SYSTEMS

CROSS-REFERENCES TO RELATED APPLICATIONS

This application claims priority on and is a continuing-in-part application of prior filed application number 10/947,055 filed on Sep. 22, 2004, published as publication number 2006-0064080, on Mar. 23, 2006, which is hereby incorporated by reference. This application also claims priority on prior filed Provisional U.S. application No. 60/891,037, filed Feb. 21, 2007, and incorporates the same by reference in its entirety.

FIELD OF THE INVENTION

The present invention relates to the field of surgical and therapeutic devices and more particularly relates to the field of laser surgical and therapeutic devices.

BACKGROUND OF THE INVENTION

Surgical and therapeutic lasers using semiconductor laser as light source have been widely used in the medicine, dentistry and other areas. In order to increase the usage by practitioners, features of laser system need to be improved. A surgical laser with a fiber management system and disposable tips was described in the parent application. The present invention, an improvement over the Parent, utilizes a modular system with wireless control, touch screen programming, a removable fiber cable, autoclaveable hand piece, and versatile surgical tips.

SUMMARY OF THE INVENTION

In view of the foregoing disadvantages inherent in the known types of laser systems, this invention provides an improved laser system with a laser module capable to provide multiple wavelengths, wireless remote control, an improved fiber optic coupling system for laser delivery, auto cleavable handpiece, replaceable tip structure. As such, the present invention's general purpose is to provide a new and improved laser system that is effective in use and easy and intuitive in that use.

To accomplish these objectives, the laser system according to the invention is practiced in two embodiments, both of which comprise a control module and a remote foot pedal operation control. In a first embodiment, the control module is a battery powered remote module which is easily maneuverable to a desired location. In the second, the control module is a relatively fixed consol and a separate handpiece is instead battery powered and movable. Both embodiments feature a laser module with multiple wavelength emission capability, a touch screen consol, a new fiber coupling system and replaceable therapeutic/surgical tips.

The more important features of the invention have thus been outlined in order that the more detailed description that follows may be better understood and in order that the present contribution to the art may better be appreciated. Additional features of the invention will be described hereinafter and will form the subject matter of the claims that follow.

Many objects of this invention will appear from the following description and appended claims, reference being made to the accompanying drawings forming a part of this specification wherein like reference characters designate corresponding parts in the several views.

Before explaining at least one embodiment of the invention in detail, it is to be understood that the invention is not limited

in its application to the details of construction and the arrangements of the components set forth in the following description or illustrated in the drawings. The invention is capable of other embodiments and of being practiced and carried out in various ways. Also it is to be understood that the phraseology and terminology employed herein are for the purpose of description and should not be regarded as limiting.

As such, those skilled in the art will appreciate that the conception, upon which this disclosure is based, may readily be utilized as a basis for the designing of other structures, methods and systems for carrying out the several purposes of the present invention. It is important, therefore, that the claims be regarded as including such equivalent constructions insofar as they do not depart from the spirit and scope of the present invention.

BRIEF DESCRIPTION OF THE DRAWINGS

FIG. 1 is a plan view of the first embodiment of the surgical laser system according to the present invention.

FIG. 2 is a plan view of a second embodiment of the invention, utilizing a wireless handpiece.

FIG. 3 depicts electronic architect of modular laser system illustrated in FIG. 1.

FIG. 4 depicts electronic architect of modular laser system illustrated in FIG. 2.

FIG. 5 is a schematic depicting a laser module to provide multiple wavelengths for the laser system.

FIG. 6(a) is a schematic depicting one of laser beam delivery mechanism designed for laser system.

FIG. 6(b) depicts a coupler housing

FIG. 6(c) depicts the assembled laser beam delivery in FIG. 6a

FIG. 6(d) depicts the optical beam trace mechanism for laser beam delivery described in FIG. 6(a).

FIG. 6(e) depicts a different laser beam delivery mechanism for designed laser system.

FIG. 6(f) depicts the assembled laser beam deliver in FIG. 6e.

FIG. 6(g) depicts the optical beam trace mechanism for laser beam delivery described in FIG. 6e.

FIG. 6(h) depicts another laser beam delivery system

FIG. 6(i) depicts assembled laser beam delivery described in FIG. 6h.

FIG. 6(j) depicts the optical beam trace mechanism for laser beam delivery described in FIG. 6h.

FIGS. 7(a) and 7(b) are schematics depicting alternate laser tips for the present invention.

FIGS. 8(a)-8(e) depict sample tips, of the design shown in FIG. 7b, set at different angles.

DETAILED DESCRIPTION OF THE PREFERRED EMBODIMENT

With reference now to the drawings, the preferred embodiment of the improved prophylactic cup is herein described. It should be noted that the articles "a", "an" and "the", as used in this specification, include plural referents unless the content clearly dictates otherwise.

FIG. 1 depicts a modular system laser with a main consol and a wireless footswitch where control consol 100 has a touch screen 101, a main electrical switch 102, a handpiece holder 103, an emergency stop button 104, a battery pack 105 to make the unit operable by battery, a USB port 106 to update system operating software, a remote control port 107 to control laser emission remotely if needed, a fiber cable 108 extending from control consol 100, a handpiece 109 con-

nected to fiber cable **108** generally opposite the consol **100** and a disposable tip **110** connected to handpiece **109**. The preferred embodiment of the system as a whole likewise comprises a cradle **111** to house the control consol **100**. The cradle **111** has an open slot **112** for consol **100** to sit. A connection pin **113** is disposed within the slot **112** to connect electrical power from cradle **111** to control consol **100**. There is a secondary slot **114** to allow fiber cable in the consol **100** to go through cradle **111** when the consol **100** sits in the cradle. An electrical cord **115**, with an appropriate power supply **116**, is connected to the cradle **111** and is in operable connection to the connector pin **113**. The electrical power supply **116** and **115** can also connect to consol **100** directly without a cradle. The preferred embodiment of the system also comprises a wireless footswitch **117** to control the laser emission. The wireless footswitch contains a footswitch **118**, a multiple color LED indicator **119** for battery and signal status, and a reset button **120**.

In FIG. 2, the laser system has a wireless laser handpiece **201** with a disposable tip **202**. The handpiece **201** is battery operated. Handpiece **201** also features an emergency stop button **203** and a laser emission indicator **204**. There is also a laser intensity adjustment control **205** on the laser handpiece **201**. Like the previous embodiment, the system contains a control consol **206** with a touch screen **207**, a main power switch **208**, a USB port **209** for programming updates, an emergency stop button **210**, a battery pack **211** and a remote control switch **212**. In this embodiment, the consol **206** also comprises a hand piece holder **213**, an open slot **214** in **213** for handpiece to sit, a removable electrical cable **215** attached to control consol **206** for charging purposes (actual connection means between the cable **215** and the open slot **214**, for charging the handpiece **201**, is not shown), and a switch power supply **216** to provide electrical power. The system also include a wireless footswitch **217** including a main footswitch **218**, a multiple color LED indicator **219** for battery and signal status and a reset button **220**.

FIG. 3 depicts the electrical architecture of the first embodiment where block (a) contains electrical design for wireless footswitch. The footswitch is powered by battery and is operated by a control logic circuit which process signals for an electronic signal emitter and receiver (denoted as ES receiver and ES emitter in the Figures). It should be noted that, as used in this application, the term “electronic signal” includes any means of wireless communication now known or later developed, including but not limited to Laser, IR, RF, and BLUETOOTH communications. Block (b) illustrates the architectural design for main control. There is a battery charging section as the unit is operated by battery. The signal is processed through control logic circuit. The information is input by touch screen through a graphic user interface. The signal from foot switch controls laser emission by sending electronic signals to the system as a whole. The control program can be updated through a USB port.

Similarly in FIG. 4, where the architecture is for the system in FIG. 2, block (a) illustrates electrical design for wireless footswitch. The footswitch is powered by battery to operate a control logic which process signals for the electronic signal emitter and receivers. Block (b) illustrates the architectural design for main control. There is a battery charging section as the control console and handpiece are operated by battery. The signal is processed through a control logic circuit. The information is inputted by touch screen through a graphic user interface. The control program can be updated by a USB port. Block (c) illustrates the architect design for a laser

signals from and to main control unit. The information is processed by control logic circuit to control laser emission. The laser emission is controlled by wireless signal from foot-switch.

Both embodiments use a laser module to generate a multiple wavelength laser beam for emission through a single fiber. It should be noted that the laser module is located in the consol in the first embodiment (FIG. 3) and the handpiece in the second (FIG. 4). FIG. 5 depicts a laser module used in both embodiments. The laser module depicted in FIG. 5 can be either a laser module capable of emitting a single wavelength or multiple wavelengths, dependent upon the types of laser chips used in the module. The laser module is encased in a metal housing **501**. Inside housing **501**, a heat sink **502** carries a laser chip **503** and a detector chip **504**. The detector chip **504** detects the laser signal so that the emission of laser power can be controlled. The laser chip **503** and detector chip **504** are bonded by conduction wires **505**, **506**, **507** respectively to the electrodes **505a**, **506a**, and **507a** on the housing **501**, respectively. In front of laser chip **504**, there is an optical lens **508** to make the emitted laser beam become a parallel beam **509** for transport.

Another heat sink **510** carries a laser chip **511** and a detector chip **512**. The laser chip and detector chips are bonded by conduction wires **513**, **514**, and **515** to the electrodes **513a**, **514a**, and **515a** respectively. There is an optical lens **516** to make the emitted laser beam become a parallel beam **517**. Both beam **509** and **517** meet with a filter/reflector **518** which is 100% transparent to beam **509** and 100% reflective to beam **517**, reflecting beam **517** to make create beam **517a**. The reflectivity and transparency of this filter/reflector **518** is due to one side of the filter/reflector **518** being transparent to all or at least most wavelengths of laser light while the other is reflective of all or most wavelengths of laser light.

Yet another heat sink **519** carries laser chip **520** and detector chip **521**. The laser chip and detector chips are bonded by conductive wires **522**, **523**, and **524** to the electrodes **522a**, **523a**, and **524a** respectively. There is an optical lens **525** to make the emitted laser beam become a parallel beam **526**. Beam **526**, **509**, **517a** meet with a filter/reflector **527** which are 100% transparent to **509** and **517a** and 100% reflective to beam **526**, reflecting beam **526** to create beam **526a**. All three beams, **509**, **517a**, **526a** reach an optical lens **528** housed by holder **529**. Lens **528** focuses all three beams into a single fiber **530**. Thus, with three generated laser beams merged into a single beam, the fiber can emit a single laser beam with three different wavelengths. It is conceivable that additional laser sources may be used to add more wavelengths to the final emitted beam.

Delivering a laser beam to a surgical surface is a key for the laser system. Several laser beam delivery mechanisms will be disclosed herein.

FIG. 6(a) describes one of the delivery mechanisms for a laser beam. Given a laser module **6001** as described in FIG. 5, the system according to the present invention is then assembled with the laser module **6001** as a centerpiece, shown in FIG. 6(a). Fiber **6002** exits module **6001** to connect to other components. A ferrule **6003** is provided to the fiber **6002** so as to connect the fiber **6002** to the next stage. A nut **6004** connected to ferrule **6003** facilitates the connection of ferrule **6003** to other connections. The fiber **6002** is finished at end of ferrule **6005** with standard fiber finish. Then, there is a housing **2007** with an opening **2008** at proximal end and another opening **2009** at distal end. There are precision spacers **2010** and **2011** at both ends of an optical lens **2012**, inside housing **2007**. The details for housing **6007** will be described in FIG. 6(b). A coupler **6013** is provided for further light

transportation. The coupler 6013 with opening 6014 at proximal end opening 6015 at distal end, and a stop point 6016 contains housing 2007. Then, a ferrule 6017 contains another fiber 6018. A nut 6019 is connected to 6017 for attachment. Fiber 6018 has a standard finish 6020 for at end 6017. At another end of fiber 6018, there is a ferrule 6021 to make fiber to connect to next stage. A nut 6022 is attached to ferrule 6021 and a fiber finish surface 6023 at end of ferrule 6020. Another housing 6024 with opening 6025 at proximal end and opening 6026 at distal end contains a precision spacer 6027 and 6028 at both end of an optical lens 6028, respectively. A coupler 6030 with opening 6031 at proximal end, opening 6032 at distal end, and a stop point 6033 to house 6024. Another ferrule 6034 to contain fiber 6035 with fiber finish 6036 can be fit to coupler 6030.

FIG. 6(b) depicts details the housing 6007 and 6024. A cylindrical housing 6101 which can be made of metal or plastic with elastic properties has an opening 6102 at proximal end, opening 6103 at distal end, and an open slot 6104 from proximal end to distal end. The important feature is the open slot 6104 to allow any ferrules with size larger than inside diameter of 6101 to get in from both ends and to automatically align the ferrules. This is important to accommodate the variance of the ferrule, as even they are in precise relation to each other.

FIG. 6(c) depicts assembled fiber conduction mechanism as layout in FIG. 6(a). A laser beam from laser module 6201 is transported through a fiber cable 6202 to a connection point 6203, which contains a coupler, a housing with one lens and spacers, and a ferrule for another fiber 6204. The laser beam is coupled from one fiber to another fiber utilizing connection points 6203. The mechanism of coupler, spacers and lens make the coupling efficiency from one fiber to another fiber to the optimum. The connection 6203 can be the transporting point to transport laser beam from inside the laser system to outside the laser system as depicted in FIG. 1 and FIG. 2. Then, laser beam is transported to another connection point 6205, contains a coupler, a housing with one lens and spacers, and a ferrule for another fiber 6206, which may deliver the laser beam to the surgical surface. The connection point 6205 can also be the transporting point from the handpiece to the replaceable tip for laser system as depicted in FIG. 1 and FIG. 2.

FIG. 6(d) depicts the optical system for laser transportation described in FIG. 6(a). A laser beam 6301 inputs to a fiber 6302, then exits from fiber 6302, then focused by lens 6303 to another fiber 6304, then exits fiber 6304, then focused by lens 6305 to another fiber 6306, finally exits at end of 6306 as a beam 6307 to an application surface.

The laser beam deliver mechanism depicted in FIG. 6(d) can be used for a laser system with power output range from 1 to 10 watt.

FIG. 6(e) describes another of the delivery mechanisms for a laser beam. Given a laser module 6401 as described above, the system according to the present invention is then assembled with the laser module 6401 as a centerpiece, shown in FIG. 6(e). Fiber 6402 exits module 6401 to connect to other components. A ferrule 6403 is provided to the fiber 6402 so as to connect the fiber 6402 to the next stage. A nut 6404 connected to ferrule 6403 facilitates the connection of ferrule 6403 to other connections. The fiber 6402 is finished at end of ferrule 6405. Then, there is a housing 2406 with an opening 2407 at proximal end and another opening 2408 at distal end. There is a precision spacer 2409, an optical lens 2410, and another precision spacer 2411 inside housing 2406. The housing 6406 is identical to housing 6007 described in FIG. 6(b). A coupler 6413 is provided for further light trans-

portation. The coupler 6413 with opening 6412 at proximal end opening 6414 at distal end. While housing 6406 is inserted within coupler 6413 at proximal end 6412, an identical housing 6415 is likewise inserted into coupler distal end 6414. The structure inside housing 6415 mirrors the structure in housing 6406 in that it contains a precision spacer 2418, an optical lens 2419, and another precision spacer 2420 inside housing 6415. Housing 6415 also presents proximal opening 6416 and distal opening 6417. Distal opening 6417 receives a ferrule 6422 containing fiber 6421, which is finished at the end of ferrule 6424. Ferrule 6422 likewise is attached to a nut 6423 to facilitate connection. This is the first part of connection fiber 6421, which has an identical structure at its other end, specifically there is a ferrule 6425 to make fiber to connect to next stage. A nut 6426 is attached to ferrule 6425 and a fiber finish surface 6427 at end of ferrule 6425. Another housing 6428 with opening 6429 at proximal end and opening 6430 at distal end contains a precision spacer 6431, an lens 6432, and a precision spacer 6433. A coupler 6434 with opening 6435 at proximal end, opening 6436 at distal end, and a stop point 6437 to house 6428. Another ferrule 6439 to contain fiber 6438 with fiber finish 6440 can be fit to coupler 6434. This construction had the added utility of an extra focusing lens over the first embodiment described in FIG. 6(a).

FIG. 6(f) depicts assembled fiber conduction mechanism as layout in FIG. 6(e). A laser beam from laser module 6501 is transported through a fiber cable 6502 to a connection point 6503, which contains a coupler, a housing with two lenses, and a ferrule for another fiber 6504. The connection point 6503 can also be the transporting point to transport laser beam from inside the system to the outside the system as depicted in FIG. 1 and FIG. 2. Then, laser beam is transported to another connection point 6505, contains a coupler, a housing with one lens, and a ferrule for another fiber 6506, which may deliver the laser beam to the surgical surface. The connection point 6506 can be the transporting point from the handpiece to the replaceable tip for laser system as depicted in FIG. 1 and FIG. 2.

FIG. 6(g) depicts the optical system for laser transportation described in FIG. 6(e). A laser beam 6601 inputs to a fiber 6602, then exits from fiber 6602, then focused by lenses 6603 and 6604 to another fiber 6605, then exits fiber 6605, then focused by lens 6606 to another fiber 6607, finally exits at end of 6607 as a beam 6608 to an application surface.

The laser beam deliver system depicted in FIG. 6(g) can be used for a laser system with moderate power output, for example, the final laser output is ranged from 1 to 15 watt.

FIG. 6(h) describes another of the delivery mechanisms for a laser beam. Given a laser module 6701 as described above, the system according to the present invention is then assembled with the laser module 6701 as a centerpiece, shown in FIG. 6(h). Fiber 6702 exits module 6701 to connect to other components. A ferrule 6703 is provided to the fiber 6702 so as to connect the fiber 6702 to the next stage. A nut 6704 connected to ferrule 6703 facilitates the connection of ferrule 6703 to other connections. The fiber 6702 is finished at end of ferrule 6705. Then, there is a housing 2706 with an opening 2707 at proximal end and another opening 2708 at distal end. There is a precision spacer 2709, an optical lens 2710, and another precision spacer 2711 inside housing 2706. The housing 6706 is identical to housing 6007 described in FIG. 6(b). A coupler 6713 is provided for further light transportation. The coupler 6713 with opening 6712 at proximal end opening 6714 at distal end. While housing 6706 is inserted within coupler 6713 at proximal end 6712, a housing 6715 is likewise inserted into coupler distal end 6714. The

structure inside housing **6715** mirrors the structure in housing **6706** in that it contains a precision spacer **2718**, an optical lens **2719**, and another precision spacer **2720** inside housing **6715**. Housing **6715** also presents proximal opening **6716** and distal opening **6717**. Distal opening **6717** receives a ferrule **6722** containing fiber **6721**, which is finished at the end of ferrule **6724**. Ferrule **6722** likewise is attached to a nut **6723** to facilitate connection. This is the first part of connection fiber **6721**, which has an identical structure at its other end, specifically there is a ferrule **6725** to make fiber to connect to next stage. A nut **6726** is attached to ferrule **6725** and a fiber finish surface **6727** at end of ferrule **6725**. Another housing **6728** with opening **6729** at proximal end and opening **6733** at distal end contains a precision spacer **6430**, an lens **6431**, and a precision spacer **6432**. A coupler **6734** is provided for further light transportation. The coupler **6734** with opening **6735** at proximal end opening **6736** at distal end. While housing **6728** is inserted within coupler **6734** at proximal end **6735**, an identical housing **6737** is likewise inserted into coupler distal end **6736**. The structure inside housing **6737** mirrors the structure in housing **6728** in that it contains a precision spacer **2738**, an optical lens **2740**, and another precision spacer **2741** inside housing **6737**. Housing **6737** also presents proximal opening **6738** and distal opening **6742**. Distal opening **6742** receives a ferrule **6743** containing fiber **6744**, which is finished at the end of ferrule **6745**. This construction had the added utility of an two extra focusing lenses over the first embodiment described in FIG. **6(a)**.

FIG. **6(i)** depicts assembled fiber conduction mechanism as layout in FIG. **6(h)**. A laser beam from laser module **6801** is transported through a fiber cable **6802** to a connection point **6803**, which contains a coupler, a housing with two lenses, spacers between lens and fiber finishes, and a ferrule for another fiber **6804**. Then, laser beam is transported to another connection point **6805**, contains a coupler, a housing with two lenses, and a ferrule for another fiber **6806**.

FIG. **6(j)** depicts the optical system for laser transportation described in FIG. **6(h)**. A laser beam **6901** inputs to a fiber **6902**, then exits from fiber **6902**, then focused by lenses **6903** and **6904** to another fiber **6905**, then exits fiber **6905**, then focused by lenses **6906** and **6907** to another fiber **6608**, finally exits at end of **6608** as a beam **6609** to an application surface. The mechanism designed in FIG. **6(j)** can be useful for high power laser delivery.

Due to the fiber coupling design in FIGS. **6(a)-6(j)**, the fiber tips for surgical purpose can be changed at any given time. A tip design with a housing and an optical lens is illustrated in FIG. **7a**. The tip comprises a casing **701** from which cannular tip **702** extends. In the cannular tip **702**, there is a channel **703** to guide fiber **708**. A cylindrical housing **704** contains an optical lens **705**, a spacer **706** and a fiber connector **707** which encompasses one end of fiber **708**. The fiber **708** will be bent according to the shape of channel **703** which can be straight or any angle. There is an open space **709** so that the tip can fit to the designated handpiece.

The tip shown in FIG. **7b** is a tip without an optical lens. Tip comprises casing **710** from which cannular tip **711** extends. In cannular tip **711**, there is a channel **712** to guide fiber **714**. There is a connector **713** encompassing fiber **714** inside tip casing **710**. The cannular tip **711** can be any angle by designing the casing so that the fiber can be any angle relative to tip axis. There is a space **715** to have tip to fit into handpiece. In either tip embodiment, the fiber in the tip can be versatile and may emit light in different patterns through the physical structure of the tip, as is known in the art and later discovered, including just at end the tip or in all directions. The structure of the tip is such that the fiber **708**, **714** is fixedly encased in

the tip, with the intention of being disposable while sacrificing as little material resources as possible. By being fixed in the tip and disposable, do not suffer the same stresses as other prior art fibers and can be gently bent to any angle during assembly with little fear of stresses and strain caused by repeated insertion and removal of fibers into other cannula systems.

Tips may be offset at any angle from an axis defined by the fiber connectors in the tip. FIGS. **8a-8e** depict the tip design of FIG. **7b** with offsets of 0°, 30°, 45°, 60° and 90° respectively. These angles are of course examples as any angle may be used since casing of each tip supports the fiber and the fiber is not stressed by being repeatedly bent to various degrees when inserted and removed from a cannula or other guide. Each tip has a casing **801a**, **801b**, etc. with a cannular tip **802a**, **802b**, etc. extending therefrom. Cylindrical connector **804a**, **804b**, etc encompasses one end of fiber **805a**, **805b**, etc., and is situated opposite cannular tip **802a**, **802b**, etc. in the housing **801a**, **801b**, etc. It is surrounded by a space **806a**, **806b**, etc. to allow for connection to the handpiece. The cylindrical connector **804a**, **804b**, etc. also defines an axis. Each cannular tip **802a**, **802b**, etc. contains a channel **803a**, **803b** etc. and is bent (as is the contained channel **803a**, **803b**, etc.) to an angle relative to the axis. Fiber **805a**, **805b**, etc. extends from cylindrical connector **804a**, **804b**, etc., through channel **803a**, **803b**, etc. and has its distal end extend out cannular tip **802a**, **802b**, etc., following the bend in the tip, thereby redirecting the laser received from the connected handpiece.

Although the present invention has been described with reference to preferred embodiments, numerous modifications and variations can be made and still the result will come within the scope of the invention. No limitation with respect to the specific embodiments disclosed herein is intended or should be inferred.

What is claimed is:

1. A laser transmission system, comprising:

- a laser generation module;
- a laser transmission fiber having a first end connected to the laser generation module and having a free end encased in a ferrule;
- a handpiece configured for connection to the free end of the laser transmission fiber and having a tip attachment structure;
- a removable tip configured for attachment to the handpiece, the removable tip comprising:
 - a casing from which a cannular portion extends, the cannular portion having a channel;
 - a fiber having a first end and second end, at least a portion of the fiber located within the channel of the cannular portion and the first end of the fiber extending from an end of the cannular portion;
 - a connector that encases the second end of the fiber, the connector held within the casing and proximate to the channel;
 - a space formed between the casing and the connector into which the tip attachment structure of the handpiece is connected; and

wherein:

- the ferrule encasing the laser transmission fiber and the connector encasing the short piece of fiber are aligned for laser transmission from the laser transmission fiber to the short piece of fiber when the removable tip is attached to the handpiece; and
- the channel directionally angles the short piece of fiber at an angle between zero degrees and ninety degrees with respect to the connector.

2. The laser transmission system of claim 1, further comprising a housing into which the connector inserts.

3. The laser transmission system of claim 2, wherein the housing is held within the casing of the removable tip.

4. The laser transmission system of claim 3, further comprising a lens located within the housing. 5

5. The laser transmission system of claim 4, further comprising a spacer located within the housing.

6. The laser transmission system of claim 5, wherein the housing accepts the ferrule on first end of the housing and the connector on a second end of the housing. 10

7. A laser transmission system, comprising:
a handpiece;

a removable tip configured for connection to the handpiece, the removable tip comprising: 15

a casing from which a cannular portion extends, the cannular portion having a curved channel therein;

a fiber configured to deliver a laser beam to a surgical surface, at least a portion of the fiber located within the curved channel and bent according to the shape of the curved channel; and 20

wherein:

the fiber comprises a first end and a second end, and wherein the second end of the fiber is encompassed within a connector; and 25

the removable tip further comprises a housing containing an optical lens, a spacer, and the connector.

8. The laser transmission system of claim 7, wherein the first end of the fiber extends from the cannular portion.

* * * * *

30