

UNITED STATES PATENT AND TRADEMARK OFFICE

BEFORE THE PATENT TRIAL AND APPEAL BOARD

INTUITIVE SURGICAL, INC.,
Petitioner,

v.

ETHICON LLC,
Patent Owner.

Case IPR2018-01703
Patent 8,616,431 B2

Before JOSIAH C. COCKS, BENJAMIN D. M. WOOD, and
MATTHEW S. MEYERS, *Administrative Patent Judges*.

WOOD, *Administrative Patent Judge*.

DECISION
Granting Institution of *Inter Partes* Review
35 U.S.C. § 314

I. INTRODUCTION

A. *Background*

Intuitive Surgical, Inc. (“Petitioner”) filed a Petition (Paper 2, “Pet.”) requesting *inter partes* review of claims 1–7, 10–14, 16–20, and 23–26 of U.S. Patent No. 8,616,431 B2 (Ex. 1001, “the ’431 patent”). Ethicon LLC (“Patent Owner”) filed a Preliminary Response. Paper 6 (“Prelim. Resp.”).

We have authority under 35 U.S.C. § 314, which provides that an *inter partes* review may not be instituted “unless . . . there is a reasonable likelihood that the petitioner would prevail with respect to at least 1 of the claims challenged in the petition.” 35 U.S.C. § 314(a). Moreover, a decision to institute under 35 U.S.C. § 314 may not institute on fewer than all claims challenged in the petition. *SAS Inst., Inc. v. Iancu*, 138 S. Ct. 1348, 1359–60 (2018).

Upon considering the Petition and Preliminary Response, we determine that Petitioner has shown a reasonable likelihood that it would prevail in showing the unpatentability of at least one of the challenged claims. Accordingly, we authorize an *inter partes* review to be instituted as to all challenged claims of the ’431 patent on all grounds raised in the Petition. Our factual findings and conclusions at this stage of the proceeding are based on the evidentiary record developed thus far (prior to Patent Owner’s Response). This is not a final decision as to patentability of the challenged claims. Any final decision will be based on the record as fully developed during trial.

B. Related Proceedings

Petitioner states that the '431 patent is the subject of Civil Action No. 1:17-cv-00871-LPS in the U.S. District Court for the District of Delaware. Pet. 8. Patent Owner states that U.S. Patent Nos. 9,585,658 B2 (“the '658 Patent”), 8,479,969 B2 (“the '969 Patent”), 9,113,874 B2 (“the '874 Patent”), 9,084,601 B2 (“the '601 Patent”), and 8,998,058 B2 (“the '058 Patent”) are also asserted in the Delaware litigation. Paper 4, 2. Petitioner is challenging these related patents in the following proceedings before the Board: (1) Case No. IPR2018-00933 (the '601 patent); (2) Case No. IPR2018-00934 (the '058 patent); (3) Case No. IPR2018-00938 (the '874 patent); (4) Case Nos. IPR2018-01247, IPR2018-01248, and IPR2018-01254 (the '969 patent); and (5) Case No. IPR2018-00936 (the '658 patent).

C. The '431 Patent

The '431 patent issued December 31, 2013 from an application filed February 9, 2012. Ex. 1001, [45], [22]. The application from which the '431 patent issued is a continuation of an application filed May 27, 2011, which is a continuation-in-part of an application that claims priority to June 4, 2007. *Id.* [63].

The '431 patent is titled “Shiftable Drive Interface for Robotically-Controlled Surgical Tool,” and discloses, *inter alia*, a surgical instrument that is actuated by a rotary motion provided by a robotic system. *Id.* at 3:27–40.

Figure 100 depicts a surgical instrument engaged with a robotic-system tool holder, and is reproduced below:

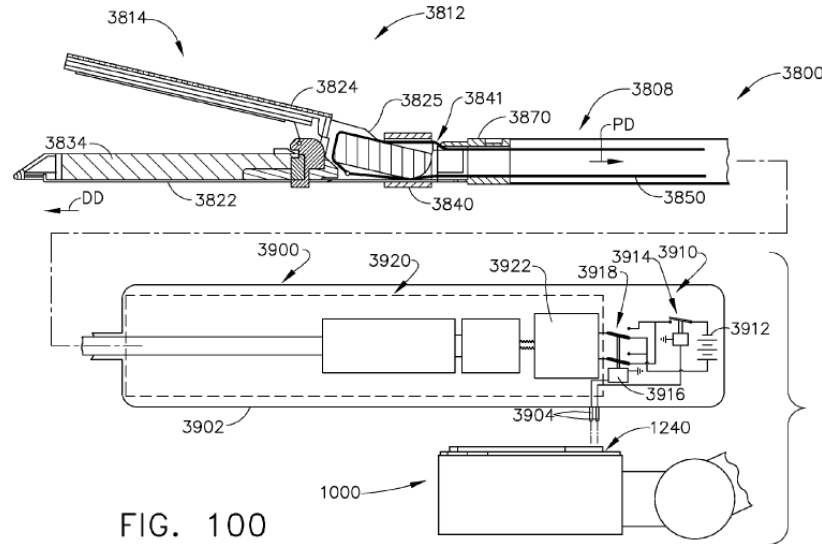

FIG. 100

Figure 100, reproduced above, depicts surgical instrument 3800 comprising endocutter 3814 coupled to elongated shaft assembly 3808, which is attached to tool mounting portion 3900. *Id.* at 61:4–8, 30–32. A cable drive transmission 3920 is operably supported on tool mounting plate 3902 of the tool mounting portion. *Id.* at 63:17–20. Tool mounting portion 3900 has an array of electrical connecting pins 3904 that interface with slots 1258 in adapter 1240 of robotic system 1000, allowing the robotic system to send control signals to the surgical instrument. *Id.* at 63:20–24, Fig. 42.

Cable drive transmission 3920 is shown in greater detail in Figures 104–106, reproduced below:

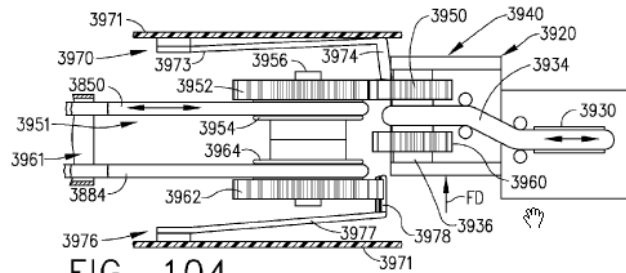

FIG. 104

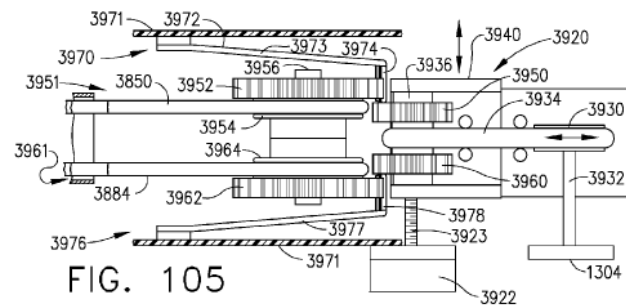

FIG. 105

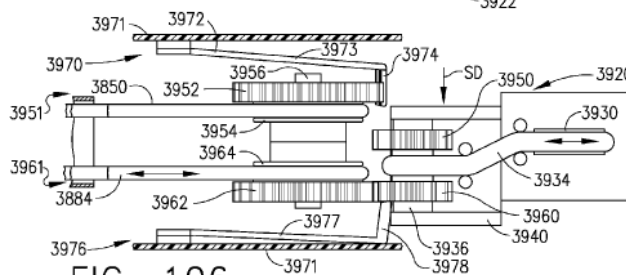

FIG. 106

As shown in Figures 104–106, reproduced above, cable drive transmission 3920 comprises drive pulley 3930 attached via a drive shaft to driven element 1304, which interfaces with drive element 1250 of adaptor 1240, discussed above. *Id.* at 63:43–48, Figs. 42, 105. This arrangement allows robotic system 1000 to apply rotary motion to drive pulley 3930, and thus surgical instrument 3800, in a desired direction. *Id.* at 63:49–51. Drive pulley 3930 is also connected to shifter yoke 3940 via belt 3934. *Id.* at 63:51–53. Shifter yoke 3940 is shiftable in a first direction and a second direction by shifter motor 3922. *Id.* at 63:53–59, Fig. 100. When the shifter yoke is shifted in the first direction, closure drive gear 3950 engages with

closure drive assembly 3951, allowing closure cable 3850 to be driven to close the end effector and clamp tissue. *Id.* at 64:44–59. When the shifter yoke is in the second position, firing drive gear 3960 engages with firing drive assembly 3961 to fire the staples and cut the tissue clamped in the end effector. *Id.* at 64:63–65:14.

D. The Challenged Claims

Petitioner challenges claims 1–7, 10–14, 16–20, and 23–26 of the '431 patent. Pet. 1. Claims 1, 14, and 20 are independent. Claim 1 is reproduced below:¹

1. [1.1] A tool mounting device for coupling a surgical end effector configured to selectively perform at least two actions in response to control motions applied thereto to a tool drive assembly of a robotic system that is operatively coupled to a control unit of the robotic system, said tool mounting device comprising:

[1.2] a tool mounting portion configured for operable attachment to the tool drive assembly of the robotic system;

[1.3] an elongated shaft assembly having a proximal end portion operably supported on said tool mounting portion and a distal end portion operably interfacing with said surgical end effector to apply said control motions thereto; and

[1.4] a transmission arrangement operably supported on said tool mounting portion

[1.5] such that when said tool mounting portion is attached to the tool drive assembly, said transmission arrangement is configured to operably interface with a rotatable drive element of the tool drive assembly to receive a rotary output motion therefrom,

[1.6] said transmission arrangement communicating with the control unit of the robotic system and being responsive to

¹ We reproduce the corrected version of claim 1. *See* Ex. 1002, 4. We also include Petitioner's limitation labels and reformatted slight for clarity. *See* Pet. 22–72.

actuation motions therefrom to move between first and second positions

[1.7] such that when said transmission arrangement is in said first position, an application of said rotary output motion thereto by said rotatable drive element of the tool drive assembly causes a first one of said control motions to be applied to a portion of said surgical end effector through said elongated shaft assembly and when said transmission arrangement is in said second position, said application of said rotary output motion thereto by said rotatable drive element of the tool drive assembly causes a second one of said control motions to be applied to another portion of said surgical end effector through said elongated shaft assembly.

E. Asserted Grounds of Unpatentability

Petitioner contends that the challenged claims are unpatentable based on the following specific grounds (Pet. 3):

No.	Reference[s]	Basis	Claim[s] Challenged
1	Tierney ² and Whitman ³	§ 103	1–6, 10–13
2	Tierney, Whitman, and Zemlok ⁴	§ 103	7, 14, 16–20, 23–26
3	Whitman	§ 102	1, 2, 6, 10–13
4	Tierney, Whitman, and Timm Application ⁵	§ 103	11

² U.S. Pat. No. 7,524,320 B2 (iss. Apr. 28, 2009) (Ex. 1005).

³ U.S. Pat. Appl. Pub. No. 2009/0101692 A1 (publ. Apr. 23, 2009) (Ex. 1004).

⁴ U.S. Pat. Appl. Pub. No.2008/0251568 A1 (publ. Oct. 16, 2008) (Ex. 1006).

⁵ U.S. Pat. Appl. Pub. No. 2008/0308601 A1 (publ. Dec. 18, 2008) (Ex. 1016).

In support of its proposed grounds, Petitioner relies on the Declaration of Dr. Bryan Knodel (Ex. 1003).

II. ANALYSIS

A. *Level of Ordinary Skill in the Art*

Petitioner's Declarant, Dr. Knodel, asserts that a person of ordinary skill in the art "would have had the equivalent of a Bachelor's degree or higher in mechanical engineering with at least 3 years working experience in the design of comparable surgical devices." Ex. 1003 ¶ 25. Dr. Knodel also asserts that "[a]dditional education in a relevant field, such as mechanical engineering or robotics (to the extent pertinent), or industry experience may compensate for a deficit in one of the other aspects of the[se] requirements." *Id.* At this stage of the proceeding, Patent Owner does not dispute this definition or otherwise proffer its own definition. On this record and for purposes of this decision, we adopt Petitioner's definition. Further, we presume that the cited prior art references reflect the level of ordinary skill at the time of the invention. *See Okajima v. Bourdeau*, 261 F.3d 1350, 1355 (Fed. Cir. 2001).

B. *Claim Construction*

The Petition in this proceeding was filed before November 13, 2018; therefore, we determine whether to institute *inter partes* review of the claims based on the "broadest reasonable construction" of the claims in light of the specification in which the claims appear. 37 C.F.R. § 42.100(b) (2018);⁶ *see*

⁶ *See* Changes to the Claim Construction Standard for Interpreting Claims in Trial Proceedings Before the Patent Trial and Appeal Board, 83 Fed. Reg.

also Cuozzo Speed Techs., LLC v. Lee, 136 S. Ct. 2131, 2142 (2016) (upholding the use of the broadest reasonable interpretation standard). Under this standard, claim terms are generally given their ordinary and accustomed meaning as understood by one of ordinary skill in the art, unless it appears from the specification, the file history, or other evidence asserted by the parties that the inventor used them differently. *In re Paulsen*, 30 F.3d 1475, 1480 (Fed. Cir. 1994). Any special definition for a claim term must be set forth in the specification with reasonable clarity, deliberateness, and precision. *Id.*

Neither party proposes constructions for any claim term. At this stage of the proceeding, no claim term requires express construction. *See Vivid Techs., Inc. v. Am. Sci. & Eng'g, Inc.*, 200 F.3d 795, 803 (Fed. Cir. 1999) (holding that only terms that are in controversy need to be construed, and “only to the extent necessary to resolve the controversy”).

*C. Patent Owner's Challenges to Institution
Under 35 U.S.C. §§ 314(a) and 325(d)*

Before addressing the merits of the Petition, we consider Patent Owner's contention that we should exercise our discretion under 35 U.S.C. §§ 314(a) and 325(d) and deny institution. We have considered Patent Owner's arguments but find them unpersuasive.

Institution of *inter partes* review under 35 U.S.C. § 314(a) is discretionary. *See* 35 U.S.C. § 314(a) (stating “[t]he Director *may not* authorize an *inter partes* review to be instituted unless the Director determines that the information presented in the petition . . . shows that there

51,340 (Oct. 11, 2018) (to be codified at 37 C.F.R. pt. 42) (changing claim construction standard for petitions filed on or after November 13, 2018).

is a reasonable likelihood that the petitioner would prevail with respect to at least 1 of the claims challenged in the petition” (emphasis added)); *Harmonic Inc. v. Avid Tech., Inc.*, 815 F.3d 1356, 1367 (Fed. Cir. 2016) (“[T]he PTO is permitted, but never compelled, to institute an IPR proceeding.”).

The exercise of our discretion to institute an *inter partes* review is informed by 35 U.S.C. § 325(d), which requires us to “take into account whether, and reject the petition . . . because, the same or substantially the same prior art or arguments previously were presented to the Office.” In applying § 325(d) based on prior *inter partes* review petitions, the Board considers the following factors:

1. whether the same petitioner previously filed a petition directed to the same claims of the same patent;
2. whether at the time of filing of the first petition the petitioner knew of the prior art asserted in the second petition or should have known of it;
3. whether at the time of filing of the second petition the petitioner already received the patent owner’s preliminary response to the first petition or received the Board’s decision on whether to institute review in the first petition;
4. the length of time that elapsed between the time the petitioner learned of the prior art asserted in the second petition and the filing of the second petition;
5. whether the petitioner provides adequate explanation for the time elapsed between the filings of multiple petitions directed to the same claims of the same patent;
6. the finite resources of the Board; and
7. the requirement under 35 U.S.C. § 316(a)(11) to issue a final determination not later than 1 year after the date on which the Director notices institution of review.

General Plastic Indus. Co. v. Canon Kabushiki Kaisha, Case IPR2016-01357, slip op. at 16 (PTAB Sept. 6, 2017) (Paper 19) (precedential). Although the *General Plastic* factors explicitly pertain to petitions challenging the same patent as previously challenged in an *inter partes* review or other proceeding under the AIA, the same or similar factors have been applied to consider allegations that the same or substantially the same prior art or arguments were considered during examination of the patent. See *NHK Spring Co. v. Intri-Plextechnologies, Inc.*, Case IPR2018-00752, slip op. at 11–12 (PTAB Sept. 12, 2018) (Paper 8) (applying similar factors in denying institution where petition asserted the same prior art considered during examination). We also note that § 325(d) is not intended to be the sole basis for the exercising our discretion to deny institution under § 314(a). *General Plastics*, slip op. at 19.

1. *Parallel District-Court Litigation*

Patent Owner first argues that we should deny institution because Petitioner delayed filing the Petition “until such time that the IPR, if instituted, would result in a final written decision only after the same validity issues have been resolved by a district court.” Prelim. Resp. 41. Patent Owner asserts that this would frustrate the AIA’s objective of providing “an effective and efficient alternative to district court litigation.” *Id.* at 40 (citing *General Plastics*, slip op. at 16–17). Patent Owner also contends that “[t]he Board has applied its discretion to deny institution under §§ 314(a) and 324(a) on facts substantially identical to those presented here.” *Id.* at 42 (citing *NHK Spring*, Paper 8).

We have considered this argument but find it unpersuasive. As an initial matter, there is no *per se* rule against instituting an *inter partes* review

when any Final Decision may issue after a district court has addressed the patentability of the same claims. Nor should there be. Instituting under such circumstances gives the district court the opportunity, at its discretion, to conserve judicial resources by staying the litigation until the review is complete, thus satisfying the AIA's objective of providing "an effective and efficient alternative to district court litigation." Moreover, as noted above and as Patent Owner points out (Prelim. Resp. 43), we would apply a different claim-construction standard than the district court would apply. Although Patent Owner asserts that "there are no claim construction issues to be resolved in this proceeding," the panel may nonetheless decide in its Final Written Decision to construe a term more broadly than the district court.

NHK Spring does not persuade us otherwise.⁷ In *NHK Spring*, the Board determined not to institute *inter partes* review under § 325(d) because the prior art asserted in that proceeding was "a subset of the same prior art that the Examiner applied in rejecting the claims during prosecution," and "the arguments that the Petitioner advanced were "substantially similar to the findings the Examiner made to reject the claims." *NHK Spring*, slip op. at 18. Although the Board also considered, and found persuasive, the patent owner's argument under § 314(a) that institution would be an inefficient use of Board resources because district-court litigation addressing the same validity issues would likely be completed before a final written decision would issue, the Board made clear that weighing the § 325(d) factors alone

⁷ *NHK Spring* has not been designated as either precedential or informative under Patent Trial and Appeal Board Standard Operating Procedure 2.

was sufficient to deny institution. *Id.* at 18–20.⁸ *NHK Spring* does not suggest, much less hold, that *inter partes* review should be denied under § 314(a) solely because a district court is scheduled to consider the same validity issues before the *inter partes* review would be complete.

2. *Section 325(d) Factors*

Second, Patent Owner argues that we should deny institution because the *General Plastic* factors weigh against institution. Prelim. Resp. 43. In particular, Patent Owner argues that “[f]actor 3 weighs strongly against institution.” *Id.* at 45. Patent Owner asserts that Petitioner has an “unfair advantage” because “Petitioner had the advantage of reviewing four of Patent Owner’s preliminary responses in related IPR proceedings before filing the current Petition,” and “Petitioner has admitted to the Board in a related proceeding that it is relying on the Board’s institution decisions in related proceedings to tailor its strategy and arguments.” *Id.* at 45 (citing IPR2018-00936, Ex. 1008, 19).

We disagree. First, none of the four *inter partes* review proceedings to which Patent Owner refers were directed to the ’431 patent; nor do any of them involve the same prior art asserted in this proceeding. Further, the Petition in this case was filed before any of the institution decisions were issued in the related proceedings, so Petitioner could not have tailored its arguments in the Petition in light of those decisions. Under these circumstances, we are not persuaded that Petitioner has gained an unfair

⁸ *NHK Spring* also differs from the present case because the patent at issue in *NHK Spring* had expired and thus the Board would have applied the same claim-construction standard as the district court. *NHK Spring*, slip op. at 19.

advantage because of the timing of the Petitioner’s filing, or that factor 3 otherwise weighs against institution.

Patent Owner also asserts that *General Plastic* factors 4, 6, and 7 weigh against institution.⁹ Regarding factor 4, Patent Owner asserts that “Petitioner was aware of the primary prior art relied upon in the Petition no later than March 20, 2018,” but “delayed for six months in filing its petition, allowing it to obtain an unfair advantage.” Prelim. Resp. 46. However, as discussed above, we are not persuaded that Petitioner’s timing in filing the Petition gave Petitioner an unfair advantage. Patent Owner’s discussion of factors 6 and 7 mirrors its argument regarding the parallel district-court litigation, which we find unpersuasive.

3. Summary

Having weighed the *General Plastic* factors, and having considered Patent Owner’s additional argument, we decline to exercise our discretion under §§ 314(a) and 325(d) to deny institution.

D. Ground 1: Claims 1–6 and 10–13—Obviousness—Tierney and Whitman

Petitioner alleges that claims 1–6 and 10–13 would have been obvious over Tierney and Whitman. Pet. 13–57. Patent Owner opposes. Prelim. Resp. 31–40.

⁹ Patent Owner asserts that factor 1 “weighs slightly in favor of institution,” factor 2 is “neutral,” and factor 5 “weighs against institution or is neutral.” Prelim. Resp. 45–46. We agree that factor 1 weighs in favor of institution because Petitioner has not previously filed a petition directed to the ’431 patent. Because no such prior petition has been filed, factors 2 and 5 are not applicable.

1. Tierney (Ex. 1005)

Tierney discloses a robotic surgical system in which a plurality of different tool types can be coupled to a robotic manipulator. Ex. 1005, 4:31–44. Figure 4 depicts an exemplary tool, and is reproduced below:

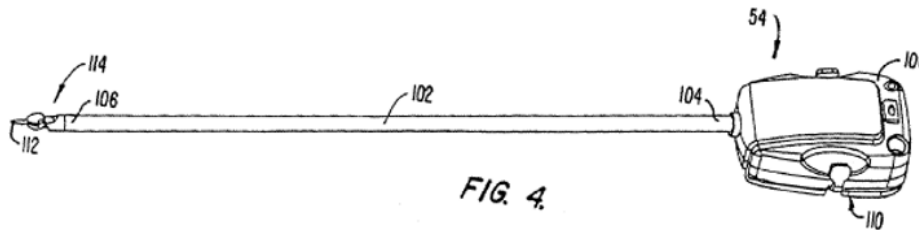
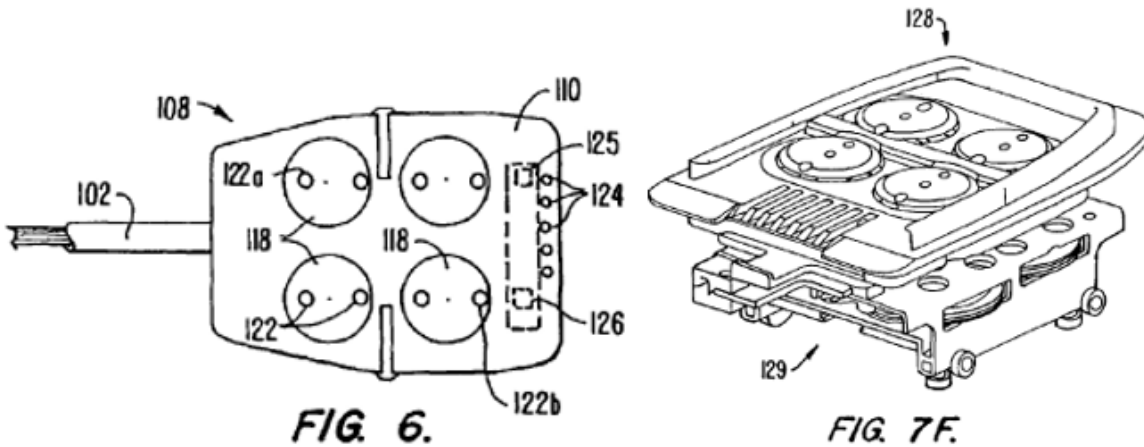

Figure 4, reproduced above, depicts tool 54 comprising rigid shaft 102 with surgical end effector 114 at the distal end and housing 108 at the proximal end. *Id.* at 9:11–13. Housing 108 includes interface 110 that mechanically and electrically couples tool 54 to a robotic manipulator. *Id.* at 9:13–15. Figures 6 and 7F of Tierney are reproduced below:



Figures 6 and 7F, reproduced above, respectively depict interface 110 and adapter 128 mounted to manipulator holder 129. *Id.* at 5:62–63, 66–67. Interface 110 comprises driven elements 118, which mechanically couple

end effector 114 to drive motors in the manipulator via adapter 128 and tool holder 129. *Id.* at 10:12–15.

2. *Whitman (Ex. 1004)*

Whitman relates to a powered, rotating, and articulating surgical device for clamping, cutting, and stapling tissue. Ex. 1004 ¶ 3. Figure 2B of Whitman depicts an exemplary device, and is reproduced below:

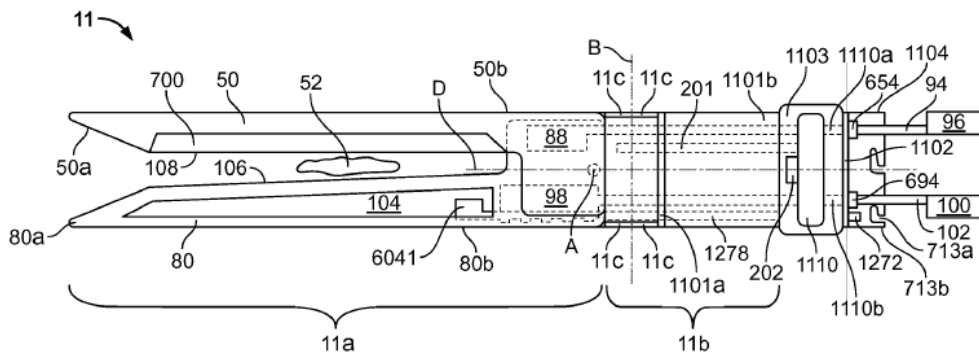

FIG. 2B

Figure 2B schematically depicts surgical device 11 comprising jaw portion 11a pivotably coupled to shaft portion 11b by hinge portion 11c. *Id.* ¶ 70. Shaft portion 11b is, in turn, coupled to handle 1103. *Id.* ¶ 72. Surgical device 11 may perform a number of different movements: jaws 50, 80 of jaw portion 11a are pivotable relative to each other about pivot axis A to clamp tissue; jaw portion 11a is pivotable relative to shaft portion 11b about hinge portion 11c and pivot axis B; and jaw and shaft portions 11a, b are rotatable relative to handle 1103 about longitudinal axis D. *Id.* ¶¶ 70–72, 74. Surgical device 11 is also capable of driving a staple-pushing element and cutting blade through tissue clamped by the jaw portion. *Id.* ¶ 82. Each of these movements and functions is performed using a separate driver: clamping driver 88, articulation driver 201, rotation driver 202, and firing

driver 98, respectively. *Id.* ¶¶ 75, 79–82. Function selection module 1110 is actuated by first rotatable drive shaft 1110a to move between four different functional positions; in each of these positions, function selector module 1110 causes engagement of second rotatable drive shaft 1110b to select one of drivers 88, 98, 201, 202, which performs the function associated with that driver. *Id.* ¶ 76. First rotatable drive shaft 1110a is driven by first motor 96 via third rotatable drive shaft 94, and second rotatable drive shaft 1110b is driven by second motor 100 via fourth rotatable drive shaft 102. *Id.* ¶ 78.

Figure 3B of Whitman depicts handle 1103 and function selector module 1110 in greater detail, and is reproduced below.

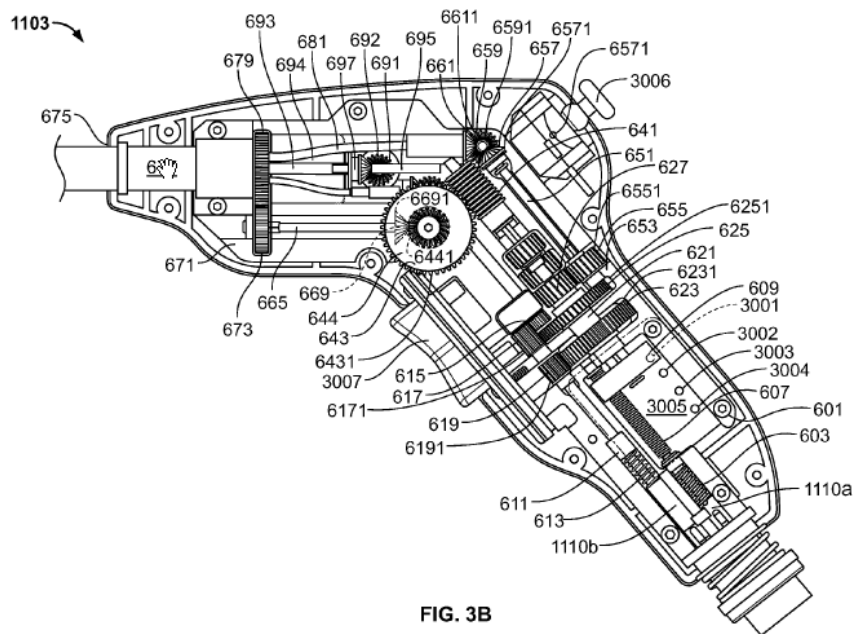

FIG. 3B

As shown in Figure 3B, reproduced above, rotation of first rotatable drive shaft 1110a causes rotation of selector shaft 601, which in turn causes function selector block 609 to move proximally or distally, depending on the rotation direction, to one of four functional positions. *Id.* ¶¶ 92–93, 114, 141. Each functional position engages one of the functional drivers with

second rotatable drive shaft 1110b, via function shaft 611, to allow second rotatable drive shaft 1110b to drive the selected driver to perform the selected function. *Id.* ¶¶ 140, 149, 157, 164–66, 174, 197, 203.

3. *Principles of Law*

“A patent for a claimed invention may not be obtained, notwithstanding that the claimed invention is not identically disclosed as set forth in [35 U.S.C. § 102], if the differences between the claimed invention and the prior art are such that the claimed invention as a whole would have been obvious before the effective filing date of the claimed invention to a person having ordinary skill in the art to which the claimed invention pertains.” 35 U.S.C. § 103. Obviousness is a question of law based on underlying findings of fact. *Graham v. John Deere Co.*, 383 U.S. 1, 17 (1966). The underlying factual considerations “include the scope and content of the prior art, the differences between the prior art and the claimed invention, the level of ordinary skill in the art, and any relevant secondary considerations” of non-obviousness, including commercial success of the patented product or method, a long-felt but unmet need for the functionality of the patented invention, and the failure of others who have unsuccessfully attempted to accomplish what the patentee has achieved. *Id.* at 17–18. The obviousness analysis should not be conducted “in a narrow, rigid manner,” but should instead focus on whether a claimed invention is merely “the result[] of ordinary innovation,” which is not entitled to patent protection. *KSR Int’l Co. v. Teleflex Inc.*, 550 U.S. 398, 406 (2007).

4. *Discussion*

a. Independent Claim 1

Petitioner’s analysis is somewhat ambiguous as to whether Tierney or Whitman is relied upon to teach certain elements. At one point in its analysis, Petitioner explains in detail how *Tierney* teaches the claimed surgical end effector, elongated shaft assembly, and transmission arrangement (Pet. 16–22), but subsequently states that, in Petitioner’s proposed combination of Tierney and Whitman, “*Whitman’s* elongated shaft assembly and end effector would be used, as would Whitman’s transmission arrangement” (*id.* at 26 (emphasis added)). For purposes of this decision, we proceed on the basis that Whitman is relied on for these limitations. Thus, “Whitman’s surgical device 11 [is used] with Tierney’s robotic system such that Whitman’s transmission is responsive to actuation motions from the controller of Tierney’s robotic system to move between at least first and second positions.” *Id.* (citing Ex. 1003 ¶ 57). In Petitioner’s proposed combination, the components of Whitman’s transmission arrangement that are in the handle would be moved to Tierney’s proximal housing 108 such that

[a] first one of Tierney’s driven elements 118 would drive Whitman’s first rotatable drive shaft 1110a (now in Tierney’s proximal housing 108), which drives selector shaft 601 to shift the position of function selector block 609, which selects the desired end effector function to be driven (rotation, articulation, clamping, or firing). A second one of Tierney’s driven elements 118 would drive Whitman’s “second rotatable drive shaft 1110b” (also, now located in Tierney’s proximal housing 108) to rotate “function shaft 611,” which provides the mechanical power to drive the selected end effector function (i.e., rotation, articulation, clamping, or firing).

Id. at 26–27 (citing Ex. 1003 ¶ 57).

Petitioner also contends that one of ordinary skill in the art would have been motivated to modify Tierney to use the surgical instrument of Whitman to, e.g., “increase the number of functions that can be performed on the end effector,” and “to improve the safety, accuracy, and speed of surgery using the Whitman device.” *Id.* at 28–29 (citing Ex. 1003 ¶¶ 59, 61). Petitioner further asserts that such a modification would have been the application of a known technique to a known system in a way that would have yielded predictable results. *Id.* at 30 (citing Ex. 1003 ¶¶ 61–62).

Patent Owner argues that Petitioner’s proposed combination cannot function because Tierney’s driven elements 118 “operate in a fundamentally different way” than Whitman’s rotatable drive shafts. Prelim. Resp. 32. Patent Owner asserts that Whitman’s “motors [96, 100] are directly connected to a low-torque/high speed drive shaft [94, 102], which is converted to low-speed/high-torque by a gearing arrangement.” *Id.* at 33 (citing Ex. 1004 ¶¶ 77–78, 213). Thus, according to Patent Owner, drive shafts 94, 102 “freely rotate[] through multiple rotations to provide the sufficient force to drive the clamping and firing mechanisms.” *Id.* (citing Ex. 1004 ¶ 224). Patent Owner contends that, in contrast, Tierney’s driven elements 118 are not high-speed, low-torque freely spinning connectors, but rather have “an end of travel in each direction.” *Id.* (citing Ex. 1005, 14:55–29¹⁰, 15:24–27). Patent Owner concludes that because of this “fundamental incompatibility,” there would have been no motivation to combine Whitman and Tierney. *Id.*

¹⁰ We assume that this is a typographical error and that Patent Owner intended to cite to lines 55–59 of column 14.

We have considered this argument but find it unpersuasive on the current record. First, it is not evident from the current record that Tierney's driven elements 118 have "an end of travel in each direction," as Patent Owner contends, because Tierney describes driven elements 118 as rotating a full 360°. Ex. 1005, 14:55–15:12. Second, and more importantly, this argument implies that Tierney and Whitman must be physically combinable to render claim 1 obvious. This is incorrect. "The test for obviousness is not whether the features of a secondary reference may be bodily incorporated into the structure of the primary reference." *In re Keller*, 642 F.2d 413, 425 (CCPA 1981). "Rather, the test is what the combined teachings of the references would have suggested to those of ordinary skill in the art." *Id.* Here, Petitioner has sufficiently explained, on the current record, how one of ordinary skill in the art would have combined Tierney and Whitman.

Patent Owner also argues that Petitioner's assertion that the proposed combination is merely the application of a known technique to manipulate a known system is inconsistent with Petitioner's previous statements made in connection with its own later-filed patent applications. Prelim. Resp. 35. Patent Owner asserts, for example, that Petitioner has described "the complexity associated with developing an endocutter for a robotic application," has taken the position that "a shiftable transmission for a robotic endocutter was *not* an obvious design choice," and has sought claims in 2014 "covering the very concept in the 431 Patent that it now argues was obvious in 2011." *Id.* at 35–37 (citing Ex. 2007 ¶ 8; Ex. 2005 ¶ 7, claim 1). It is unclear, however, whether and the extent to which this evidence is relevant to the obviousness of the specific claims under consideration, particularly given that Petitioner has not yet had an opportunity to respond to

it. This evidence is better addressed on a complete record. Thus, we are unable to say, at this stage of the proceeding, that the evidence is sufficient to outweigh Petitioner's obviousness showing.

In summary, we determine, on the present record, that Petitioner adequately identifies where all the elements of claim 1 are found in the prior art, and demonstrates adequate reasoning to combine the teachings of Tierney and Whitman.

b. Claims 2–6 and 10–13

Claims 2–6 and 10–13 ultimately depend from claim 1. Petitioner asserts that either Tierney or Whitman teaches each of the additional limitations of these claims. Pet. 36–57. Petitioner supports these assertions with citations to the record and with the testimony of Dr. Knodel. At this stage of the proceeding, Patent Owner does not dispute these assertions or raise arguments separate from those discussed above with respect to claim 1. At this stage of the proceeding, Petitioner has sufficiently shown that Tierney and/or Whitman teaches the additional limitations of these claims.

5. *Summary as to Ground 1*

Based on the current record, and for purposes of this decision, we determine that Petitioner has sufficiently shown that the combination of Tierney and Whitman teaches or suggests the limitations of claims 1–6 and 10–13, and that one of ordinary skill in the art would have had reasons to combine Tierney and Whitman. Accordingly, we determine that Petitioner has established a reasonable likelihood of showing that claims 1–6 and 10–13 would have been obvious over Tierney and Whitman.

E. Ground 2: Claims 7, 14, 16–20, and 23–26—Obviousness—Tierney, Whitman, and Zemlok

Claim 7 depends from claim 6. Claim 6 depends from claim 1 and additionally recites that the transmission arrangement comprises a first control assembly, a second control assembly, and a transmission shifter assembly configured to, in response to control inputs from the robotic system's control unit, shift between first and second positions to apply the rotary output motion to the first and second control assemblies respectively. Claim 7 additionally recites that the transmission shifter assembly comprises:

a shifter drive gear configured to receive said rotary output motion from said rotatable drive element of the tool drive assembly when said tool mounting portion is coupled thereto;

a shifter shaft in meshing engagement with said shifter drive gear; and

a shifter driven gear mounted on said shifter shaft such that rotation of said shifter shaft rotates said shifter driven gear and wherein said shifter driven gear is selectively axially movable on said shifter shaft between said first position wherein said shifter driven gear is in driving engagement with said first control assembly and said second position wherein said shifter driven gear is in driving engagement with said second control assembly in response to said control inputs.

Independent claims 14 and 20 recite the same first control assembly, second control assembly, and transmission shifter assembly limitations of claim 7. Claims 16–19 ultimately depend from claim 14, and claims 23–26 ultimately depend from claim 20.

Petitioner contends that Zemlok teaches these limitations. Pet. 57–71. Zemlok discloses “a powered surgical instrument having a drive gear configured to be movable to affect rotation, articulation and actuation of the

instrument.” Ex. 1006 ¶ 2. Zemlok’s instrument comprises a shift motor that selectively moves a drive gear between a plurality of positions, where each position enables different actions, such as rotation of an end effector, articulation of the end effector, and actuation of the surgical instrument. *Id.* ¶¶ 47–48. Petitioner contends that this arrangement corresponds to the transmission shifter assembly limitations of claims 7, 14, 16–20, and 23–26. Pet. 61–63 (citing Ex. 1006 ¶¶ 47–48, Figs. 5–7, 9–11, 14). Petitioner further contends that one of ordinary skill in the art would have been motivated to use Zemlok’s transmission because, among other reasons, “it is more compact and uses fewer parts (i.e., can be less expensive) than Whitman’s transmission.” *Id.* at 63 (citing Ex. 1003 ¶ 113). These contentions—which Patent Owner does not dispute at this stage of the proceeding—are supported by specific citations to the record and by Dr. Knodel’s testimony.

On this record, Petitioner adequately identifies where all the elements of claims 7, 14, 16–20, and 23–26 are found in the prior art, and demonstrates adequate reasoning to combine Tierney, Whitman, and Zemlok. Accordingly, we determine that Petitioner has established a reasonable likelihood of showing that claims 7, 14, 16–20, and 23–26 would have been obvious over Tierney, Whitman, and Zemlok.

F. Ground 3: Claims 1, 2, 6, and 10–13—Anticipation—Whitman

For Ground 3, Petitioner asserts that Whitman anticipates claims 1, 2, 6, and 10–13. Pet. 71–86. In particular, Petitioner contends that Whitman discloses “[a] tool mounting device for coupling a surgical end effector . . . to a tool drive assembly of a robotic system,” as recited in claim 1. *Id.* at 71–73 (citing Ex. 1004 ¶¶ 70, 73, 212, 215, 217–218, 220, 230–232, Figs.

2A, 2B, 3A, 3B; Ex. 1003 ¶¶ 160, 162–164). According to Petitioner, Whitman’s handle 1103 corresponds to the claimed tool mounting device, and electromechanical driver component 1610 corresponds to the claimed tool drive assembly of a robotic system. *Id.* at 71 (citing Ex. 1004 ¶¶ 70, 73, 313, Figs. 2A, 2B, 3A, 3B). Petitioner asserts that the combination of electromechanical driver component 1610 and surgical device 11 is a “robotic system” because “it is a self-powered, steerable, computer-controlled device that can be programmed to aid in the positioning and manipulation of surgical instruments, and act as a remote extension of a human surgeon.” *Id.* at 72 (citing Ex. 1003 ¶¶ 162–164). Petitioner notes, for example, that Whitman’s electromechanical driver component 1610 comprises “controller 1122” that is “configured to control all functions and operations of the electro-mechanical driver component 1610 and the linear clamping, cutting and stapling device 11.” *Id.* (citing Ex. 1002 ¶ 220). Petitioner also notes that Whitman’s surgical instrument “is steerable via steering cables attached to the flexible shaft [1620] connecting the instrument to the electro-mechanical driver.” *Id.* at 73 (citing Ex. 1003 ¶ 162; Ex. 1004 ¶¶ 212, 215, 217–218, 231–232). Petitioner contends that Whitman discloses the other limitations of claim 1 and of claims 2, 6, and 10–13, and supports its contentions with specific citations to Whitman and with Dr. Knodel’s testimony.

Patent Owner disputes that Whitman teaches the claimed tool mounting portion configured for operable attachment to the tool drive assembly of the robotic system. Prelim. Resp. 26–30. Patent Owner asserts that Whitman is “a handheld device,” and the ’431 patent “clearly distinguishes handheld devices, such as Whitman, from ‘robotic . . .

systems.” *Id.* According to Patent Owner, the ’431 patent describes “a robotic system 1000” that has “basic elements”: (1) a “master controller 1001” that “generally includes controllers ‘which are grasped by the surgeon and manipulated in space while the surgeon views the procedure via a stereo display 1002’”; (2) a “robotic arm cart 1100”; (3) a “tool mounting portion”; (4) a “tool drive assembly”; and (5) “an interface 1230 which mechanically and electrically couples the tool mounting portion 1300 to the manipulator’ of the robotic arm cart.” *Id.* at 27 (citing Ex. 1001, 26:40–49, 55–57, 28:1–5). Patent Owner contends that “Whitman does not disclose any of these elements.” *Id.* at 29.

On this record, we determine that Petitioner has adequately identified where Whitman discloses all of the limitations of claims 1, 2, 6, and 10–13. Further, we are not persuaded, on the current record, that the ’431 patent “clearly distinguishes” handheld devices from robotic systems. The ’431 patent does not expressly define the term “robotic system,” or expressly distinguish robotic systems from handheld devices. The excerpts from the ’431 patent on which Patent Owner relies are descriptions of specific embodiments, and thus we do not read them as establishing an express or implied definition of the term.

In summary, we determine that Petitioner has established a reasonable likelihood of showing that Whitman anticipates claims 1, 2, 6, and 10–13.

*G. Ground 4: Claim 11—Obviousness—
Tierney, Whitman, and the Timm Application*

Claim 11 depends from claim 10. Claim 10 depends from claim 1 and additionally recites “wherein said elongated shaft assembly has an articulation joint therein such that upon application of said first control

motion to said surgical end effector, said surgical end effector articulates about a first tool articulation axis that is substantially transverse to a longitudinal tool axis defined by said elongated shaft assembly.” Claim 11 additionally recites “wherein said articulation joint is configured to enable said surgical end effector to pivot about a second tool articulation axis upon application of another said control motion to said surgical end effector.”

Petitioner contends that the Timm Application discloses the two-axis articulation joint recited in claim 11. Pet. 86–87 (citing Ex. 1016 ¶ 182, Fig. 41; Ex. 1003 ¶ 203). Petitioner further contends that one of ordinary skill in the art would have been motivated to modify Whitman to add the Timm Application’s second articulation pivot joint to, among other things, provide a surgeon with “a greater range of motion than with just a single articulation axis.” *Id.* at 87 (citing Ex. 1003 ¶ 204; Ex. 1017, 2:51–57). These contentions—which Patent Owner does not dispute at this stage of the proceeding—are supported by specific citations to the record and by Dr. Knodel’s testimony. On this record, Petitioner adequately identifies where all the limitations of claim 11 are found in the prior art, and demonstrates adequate reasons to combine Tierney, Whitman, and the Timm Application. Accordingly, we determine that Petitioner has established a reasonable likelihood of showing that claim 11 would have been obvious over Tierney, Whitman, and the Timm Application.

III. CONCLUSION

For the foregoing reasons, we determine that Petitioner has shown that there is a reasonable likelihood that it would prevail with regard to at least one of the claims challenged in the Petition. Accordingly, we institute *inter partes* review. 35 U.S.C. § 314(a). At this stage of the proceeding, we have

IPR2018-01703
Patent 8,616,431 B2

not made a final determination as to the patentability of any challenged claim or any underlying factual or legal issue.

IV. ORDER

For the reasons given, it is

ORDERED that, pursuant to 35 U.S.C. § 314(a), an *inter partes* review of claims 1–7, 10–14, 16–20, and 23–26 of U.S. Patent 8,616,431 B2 is instituted on all grounds asserted in the Petition; and

FURTHER ORDERED pursuant to 35 U.S.C. § 314(a) and 37 C.F.R. § 42.4 that notice is hereby given of the institution of a trial, which commences on the entry date of this Decision.

PETITIONER:

Steven R. Katz
John C. Phillips
Ryan P. O'Connor
Fish & Richardson
3200 RBC Plaza,
60 South Sixth Street
Minneapolis, MN 55402

PATENT OWNER:

Anish R. Desai
Elizabeth Stotland Weiswasser
Adrian Percer
Christopher T. Marando
Christoper M. Pepe
Weil, Gotschal & Manges LLP
767 Fifth Avenue
New York, NY 10153