



US008104481B2

(12) **United States Patent**  
**Pederson et al.**

(10) **Patent No.:** **US 8,104,481 B2**  
(45) **Date of Patent:** **\*Jan. 31, 2012**

(54) **DEVICE AND METHOD FOR TREATMENT OF LIGHT DIFFICIENT DISORDERS**

(58) **Field of Classification Search** ..... 607/88-94;  
128/898; 600/26  
See application file for complete search history.

(75) Inventors: **Larry V. Pederson**, Medicine Hat (CA);  
**Clayton G. Coffey**, Medicine Hat (CA);  
**Henry Hudema**, Medicine Hat (CA)

(56) **References Cited**

(73) Assignee: **The Litebook Company Ltd.**, Medicine Hat (CA)

U.S. PATENT DOCUMENTS

(\* ) Notice: Subject to any disclaimer, the term of this patent is extended or adjusted under 35 U.S.C. 154(b) by 919 days.

This patent is subject to a terminal disclaimer.

4,564,886	A *	1/1986	Morcheles	362/97
4,858,609	A *	8/1989	Cole	607/91
4,977,489	A *	12/1990	Fung	362/184
5,149,184	A *	9/1992	Hughes et al.	362/1
5,163,426	A *	11/1992	Czeisler et al.	607/88
5,167,228	A	12/1992	Czeisler et al.	
5,176,133	A *	1/1993	Czeisler et al.	607/88
5,197,941	A *	3/1993	Whitaker	600/27
5,280,625	A	1/1994	Howarter et al.	
5,301,090	A *	4/1994	Hed	362/558
5,304,212	A *	4/1994	Czeisler et al.	607/88
5,447,527	A	9/1995	Waldman	
5,447,528	A	9/1995	Gerardo	
5,503,637	A	4/1996	Kyricos et al.	

(Continued)

(21) Appl. No.: **10/980,272**

FOREIGN PATENT DOCUMENTS

(22) Filed: **Nov. 4, 2004**

DE 296 00 470 5/1996

(65) **Prior Publication Data**

US 2005/0113891 A1 May 26, 2005

OTHER PUBLICATIONS

**Related U.S. Application Data**

Appendix A (Bio-Brite Jet Lag Calculator and light therapy systems brochure).\*

(63) Continuation of application No. 09/710,782, filed on Nov. 13, 2000, now Pat. No. 6,875,225.

(Continued)

(30) **Foreign Application Priority Data**

Mar. 14, 2000 (CA) ..... 2300569  
Aug. 30, 2000 (CA) ..... 2317319

*Primary Examiner* — Ahmed Farah  
(74) *Attorney, Agent, or Firm* — Bennett Jones LLP

(51) **Int. Cl.**  
**A61B 19/00** (2006.01)  
**A61N 5/06** (2006.01)

(57) **ABSTRACT**

A light therapy device is taught including a light emitting assembly having light emitting diodes (LEDs) as a light source. The light emitting assembly capable of generating 2,500 lux to 7,500 lux at 12 inches.

(52) **U.S. Cl.** ..... 128/898; 607/88; 607/90; 600/26

**18 Claims, 3 Drawing Sheets**

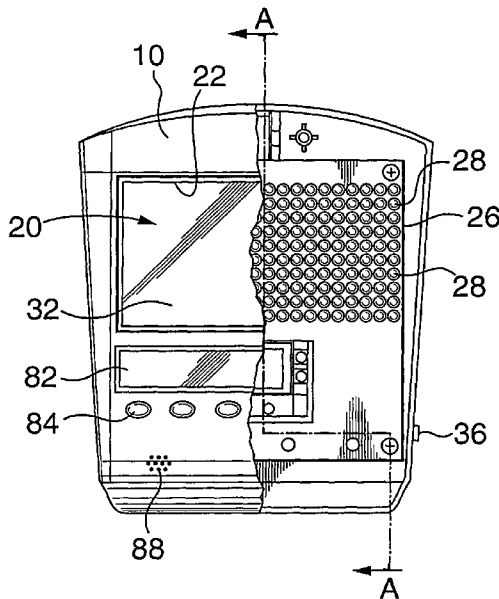

U.S. PATENT DOCUMENTS

5,545,192	A	8/1996	Czeisler et al.	
5,589,741	A *	12/1996	Terman et al.	315/360
5,782,895	A	7/1998	Zarate et al.	
5,800,479	A	9/1998	Thiberg	
5,824,024	A	10/1998	Dial	
5,879,155	A	3/1999	Kittelsen	
5,919,217	A	7/1999	Hughes	
5,923,398	A	7/1999	Goldman	
6,135,117	A	10/2000	Campbell et al.	
6,164,787	A	12/2000	Seki et al.	
6,167,648	B1	1/2001	Dimmick	
6,235,046	B1	5/2001	Gerdt	
6,299,632	B1	10/2001	Jaillet	
6,328,460	B1 *	12/2001	Grossman et al.	362/427
6,350,275	B1	2/2002	Vreman et al.	
6,443,977	B1 *	9/2002	Jaillet	607/88
6,488,698	B1	12/2002	Hyman	
6,554,439	B1 *	4/2003	Teicher et al.	362/2
6,663,659	B2 *	12/2003	McDaniel	607/88
7,118,563	B2 *	10/2006	Weckwerth et al.	606/9

OTHER PUBLICATIONS

Inexpensive ganzfeld light therapy for relaxation, meditation, depression; <http://www.morningstarlight.com/pricing.html>, Nov. 27, 1999.

Description of the Technology; Morning StarLight; Morning StarUght Light Therapy System for Seasonal Affective Disorder, SAD, Meditation, Relaxation; Nov. 27, 1999.

The Practical Method to Prevent Jet Lag Based on Breakthrough Research; Jet Lag Calculator; Bio-Brite, Inc. ©1994.

Light Therapy Products; Products, Lamps—LightTherapy Products; [http://www.lighttherapyproducts.com/products\\_lamps/html](http://www.lighttherapyproducts.com/products_lamps/html), Jan. 2, 1999.

R.W. Lam and A.J. Levitt; Canadian Consensus Guidelines for the Treatment of Seasonal Affective Disorder. A Summary of the Report of the Canadian Consensus Group on SAD; <http://www-ths.mcmaster.ca/direct/sad2.html>; Aug. 19, 1999.

C.E. Reme et al, Bright light therapy in focus: lamp emission spectra and ocular safety; Technology and Health Care 4 (1996) 403-413 IOS Press.

Outside In's Home Page; Outside in Home Page: Info on SAD, Body Clock, Jetlag, Winter Depression and Light; <http://www.outsidein.co.uk/index.htm>; Jun. 19, 1999.

R.W. Lam and A.J. Levitt; Clinical Guidelines for the Treatment of Seasonal Affective Disorder; 1999; Clinical & Academic Publishing; Canada.

I.Hecker et al. Preventing Jet Lag, Bio-Brite Inc. © 1995.

\* cited by examiner

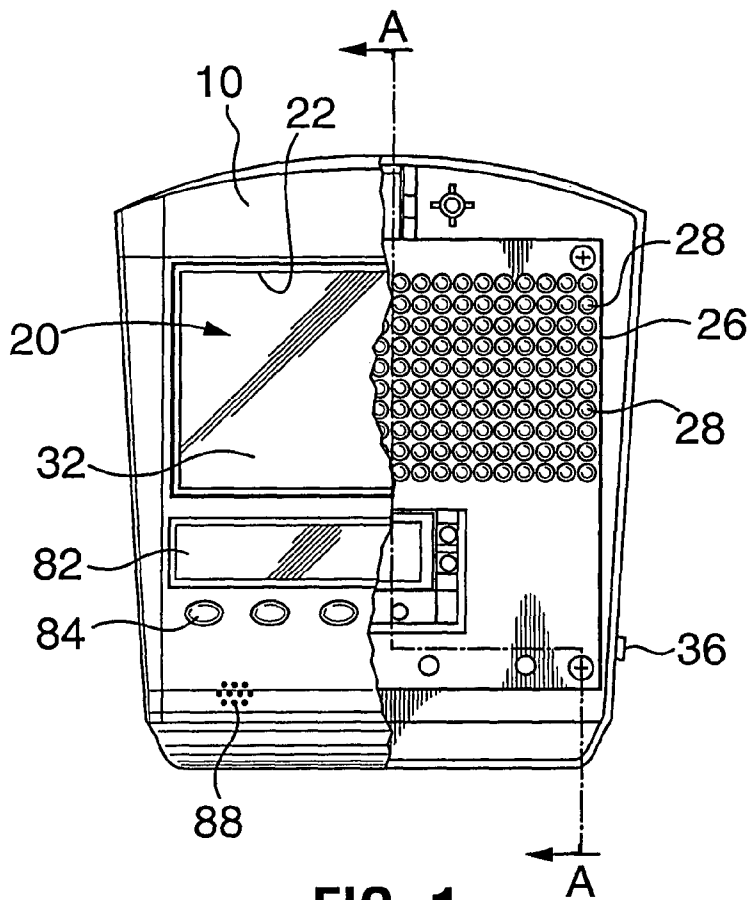

FIG. 1

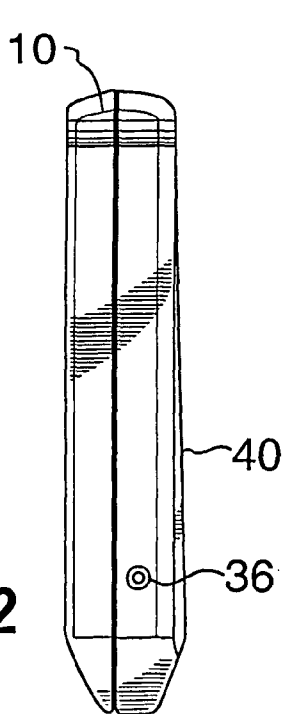

FIG. 2

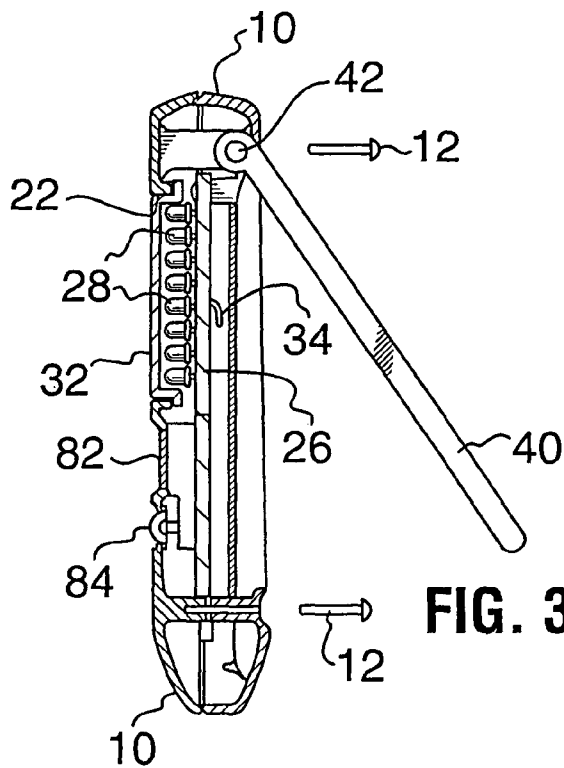
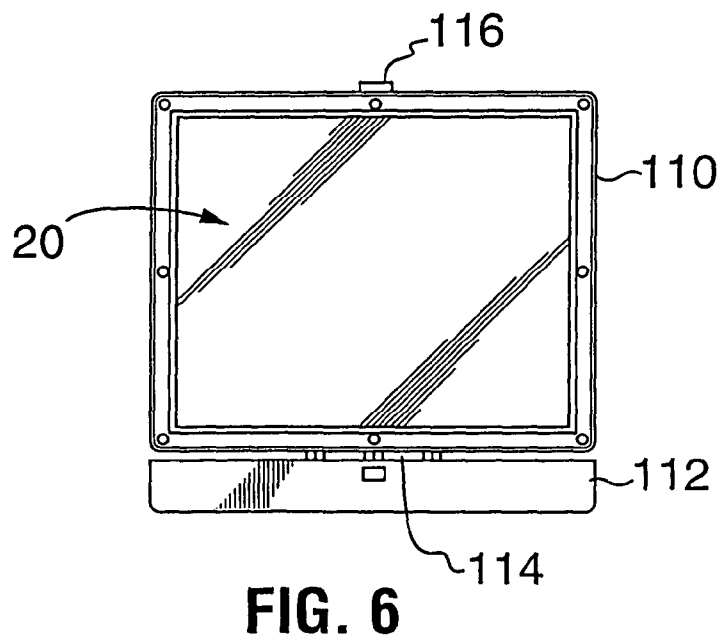
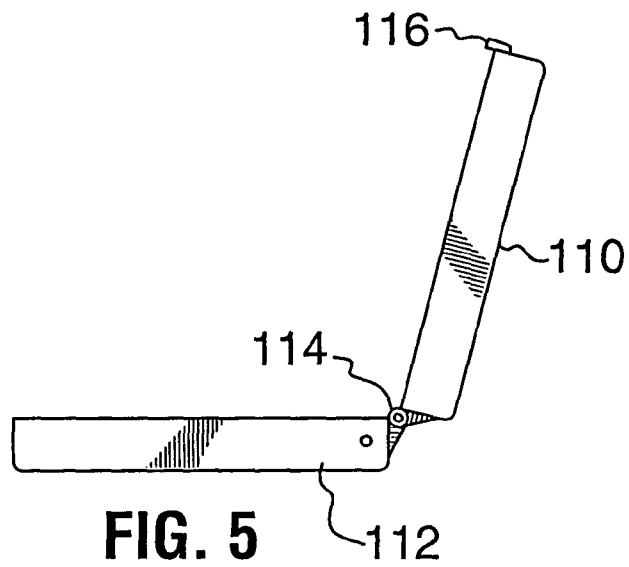
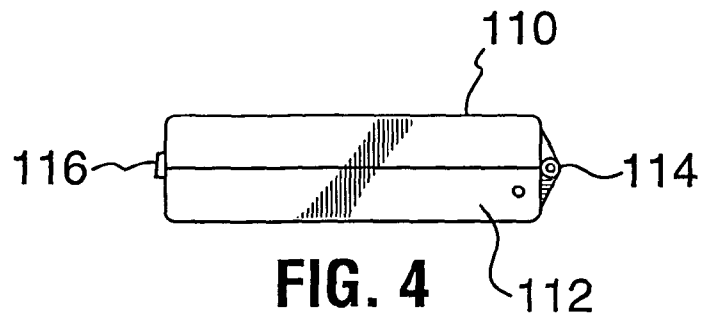

FIG. 3



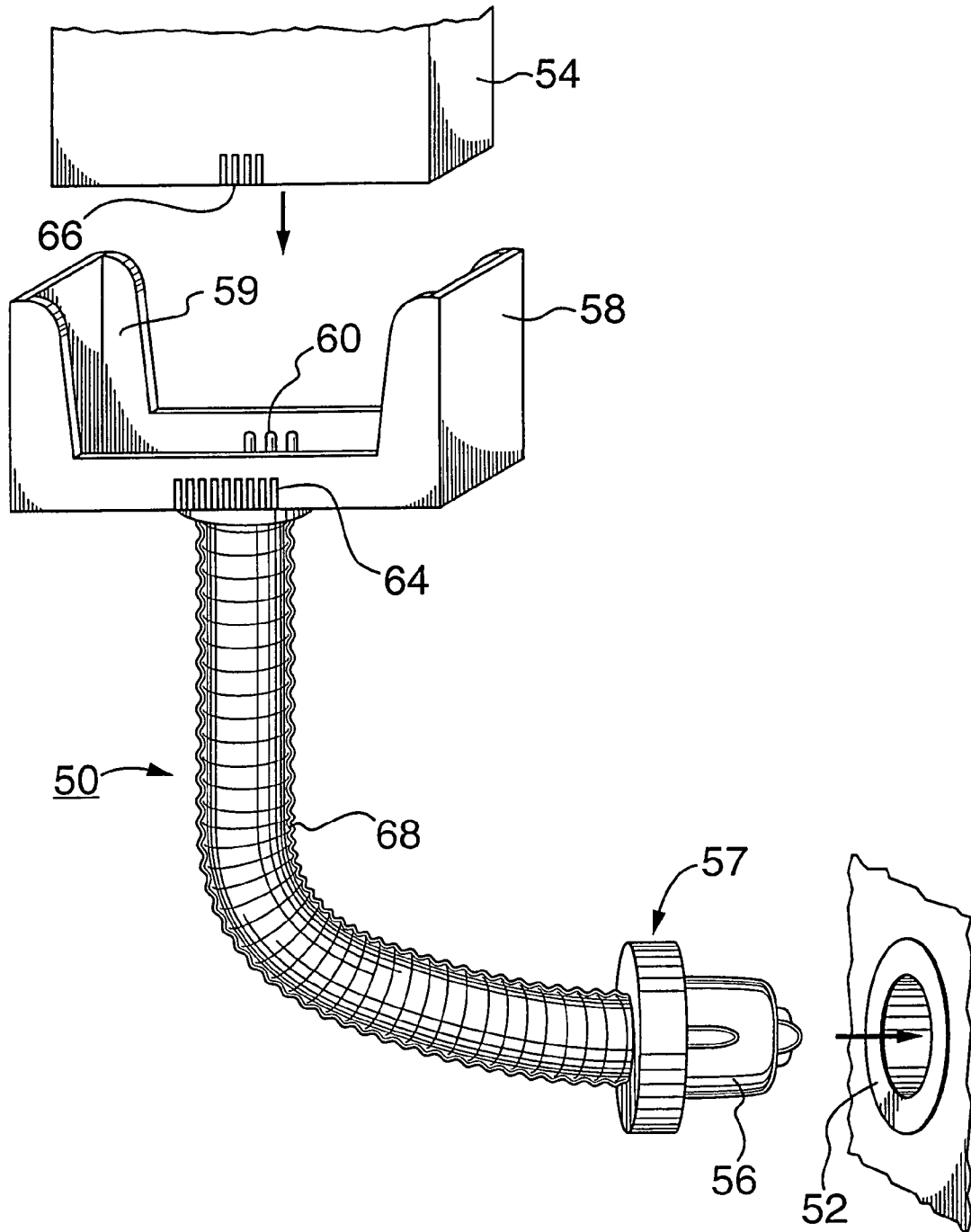

FIG. 7

1

## DEVICE AND METHOD FOR TREATMENT OF LIGHT DEFICIENT DISORDERS

### CROSS REFERENCE TO RELATED APPLICATIONS

This application is a continuation of U.S. patent application Ser. No. 09/710,782, filed Nov. 13, 2000 now U.S. Pat. No. 6,875,225, now allowed, incorporated herein by reference.

### FIELD OF THE INVENTION

The present invention relates to a light therapy device and in particular to a light therapy device for treatment of light deficient disorders.

### BACKGROUND OF THE INVENTION

There is much support for the use of light therapy to overcome light deficient disorders. It has been proven that treatments involving shining light directly towards a patient's eyes will alleviate or cure light deficient disorders including Seasonal Affective Disorder (SAD), circadian sleep disorders and circadian disruptions associated with jet-lag, shift-work, PMS and bulimia.

There are two types of light therapy devices presently available. One type of device is large in size and floor or desk mountable. These devices include light sources of fluorescent bulbs. Although they can be moved from one position to another, they are not generally portable. In addition, the light source is quite fragile. The second kind of light therapy devices is head mountable. These devices are formed as eyeglasses or visors. While they are portable, they are not generally accepted by patients for use in public because of their odd appearance when worn on the head. This combined with safety concerns about eye damage given the proximity of the light source to the eye, has resulted in head mountable treatment devices failing to be generally accepted as a light therapy device.

These devices therefore are of limited use for persons requiring a portable and discreet treatment device. A light therapy device is needed for use by, for example, the business traveler that is portable and aesthetically appealing.

### SUMMARY OF THE INVENTION

The present invention provides a portable and lightweight hand-held light therapy device. The device is durable, being resistant to damage by normal transport. The device uses light emitting diodes (LEDs) as a source of light. LEDs offer a light source that is lightweight, small in size, simple, durable as well as energy efficient. The device is useful for travel and for in-flight use while being aesthetically acceptable.

In accordance with one aspect of the present invention, there is provided a light treatment comprising: an outer housing including a opening; a light emitting assembly in the housing and operable to emit light through the opening in the housing, the light emitting assembly including a plurality of LEDs capable of generating 2,500 lux to 7,500 lux at 12 inches.

The LEDs include at least some capable of emitting white-light. In one embodiment, the LEDs are arranged in a pattern over an area and the light emitting assembly is selected to emit light from the LEDs along a substantially straight line directly toward the user. Preferably, a diffuser screen of light diffusing sheet material is positioned over the LEDs to provide a more

2

uniform emission of light. While LEDs do not emit any significant amount of ultraviolet radiation, the diffuser sheet material can include a UV filter, if desired.

The outer housing can include a first member and a second member, the first member and the second member being releasably locked together and the light emitting assembly being storable in the first member and being mountable on the housing such that the housing acts as a base to support the light emitting assembly. In one embodiment, the first and second members are pivotally connected and openable in a manner similar to a book. The first and second members, when closed enclose an inner compartment accessible by opening the first and second members about their pivotal connection. The light emitting assembly is storable in the inner compartment.

In this embodiment, the light emitting assembly can be mountable on the first member and the second member can act as a base.

To facilitate therapy using the device, the housing can also accommodate a therapy calculator for determining a treatment regime based on an input of information.

### BRIEF DESCRIPTION OF THE DRAWINGS

FIG. 1 is a front elevation view of a light therapy device according to the present invention. A portion of the device has been cut away to facilitate illustration of internal components.

FIG. 2 is a side elevation view of the light therapy device of FIG. 1 with the support leg folded against the housing.

FIG. 3 is a sectional view along line A-A of FIG. 1.

FIG. 4 is a side elevation view of another light therapy device according to the present invention in a closed configuration.

FIG. 5 is a side elevation view of the device of FIG. 4 in an open configuration, ready for use.

FIG. 6 is a front elevation of the device and configuration of FIG. 5.

FIG. 7 is an elevation of a device for permitting mounting of a light therapy device in a passenger compartment of a vehicle. The device is aligned for insertion into a power port of a vehicle and a light therapy device is aligned for insertion into the docking bay of the device.

### DETAILED DESCRIPTION OF THE PREFERRED EMBODIMENTS

Referring to FIGS. 1 to 3, a light therapy device according to one embodiment of the present invention is shown. The device is small in size and resembles a large calculator or hand-held computer. Preferably, the outside dimensions of the device are less than about 7 inches wide, 7 inches high and 1.5 inches deep. The size can be varied as desired and with consideration as to portability, convenience and the components that must be contained therein.

The device includes an outer housing 10. The housing is preferably formed of a durable, impact resistant material such as, for example, a polymer (i.e. nylon, thermoplastic or blends thereof). Preferably, all housing parts are of minimal thickness to provide suitable impact resistance and support for internal components while minimizing the weight of the device. The housing can be formed, as shown, in parts secured together by screws 12 or other fastening means.

The housing carries a light emitting assembly 20. The light emitting assembly is mounted in the housing such that in operation light emitted therefrom is directed out through an opening 22 in the housing.

Light emitting assembly **20** includes a printed circuit (PC) board **26** providing electrical connection for light emitting diodes **28**. The LEDs are spaced apart on the board, with consideration as to their light output and wavelength, such that the assembly emits a light of illumination adequate for treatment of light deficient disorders. In particular, the light emitting assembly generates adequate illumination for treatment of light deficient disorders including Seasonal Affective Disorder (SAD), circadian sleep disorders and circadian disruptions associated with jet-lag, shift-work, PMS and bulimia, which is between 2,500 and 7,500 lux, and preferably between about 3,500 and 5,500 lux at 12 inches from the assembly. To generate this level of illumination, the assembly generally includes between about 10 and 150 LEDs together having a total light output of between 50 and 500 candelas and preferably about 250 to 450 candelas. The number of LEDs in the light emitting assembly may be reduced considerably as the efficiency of a LED is increased.

Using a light therapy device according to the present invention, treatments of acceptable duration can be administered. As an example, treatments for SAD can be completed in  $\frac{1}{4}$  to 4 hours and in most cases,  $\frac{1}{2}$  to 3 hours.

For bright-light therapy, preferably white LEDs are used. However, it is sometimes useful to combine light of different wavelengths and in some instances to approximate the spectral properties or distribution of a tropical sunrise. Therefore, LEDs **28** can be entirely of the type emitting white light or, alternatively, LEDs emitting light of various wavelengths (i.e. red or amber) can be used with white light emitting diodes. The light generated by the light emitting assembly is preferably constant, though it may also be pulsed.

In one embodiment, a diffuser screen **32** is mounted over the diodes to create a more uniform, less harsh light emission. Preferably, LEDs **28** are mounted a suitable distance from diffuser screen **32** such that the light emitted by each LED overlaps on the screen and avoids the appearance of individual points of light behind the screen. If a diffuser screen is used, it is necessary to ensure that adequate levels of light, as set out above, are passed therethrough to permit treatment.

Power is supplied to the LEDs through electrical lines **34**. Power can be provided through batteries or preferably, to reduce weight, through a jack **36** for connection to a 120 v electrical supply (for use in North America). The device preferably operates using DC power and is supplied with an external AC-DC converter. Since the device is particularly useful during long distance travel in the treatment of jet lag, an adapter can be provided within the device or separately for device compatibility with foreign voltages of AC power or with DC power, as is provided through power ports mounted in aircraft armrests.

To facilitate light treatment, a support leg **40** can be provided for supporting the housing in a propped position such that light is emitted in a generally horizontal direction. In one embodiment, support leg **40** is connected by a hinge **42** to the rear of the housing such that the leg can be rotated between a supporting position and a stored position against the rear of the housing. A more complex stand for elevating the light illuminating assembly can be used, as desired.

The light treatment device can be mounted in a vehicle passenger compartment including, for example, a passenger or operator seat area. The vehicle can be, for example, an aircraft, a train, a bus, a truck or an automobile. In one embodiment, the light treatment device is mounted in an aircraft seat back or in an aircraft seat armrest for use by air travelers. The device can be mounted in a manner similar to aircraft telephones, individual video monitors, and other such devices, wherein the light treatment device is attached to an

adjustable extension arm, thereby enabling the user to remove the light treatment device from an armrest and position it appropriately for treatment. Alternately, the light treatment device may be temporarily removed from its seat back mounting position and positioned on a tray table or other surface for treatment, while remaining secured to the seat back by means of a cable that could also serve as a power source. The device may also be mounted into an airliner flight deck or other such areas of an airliner to provide discreet and convenient light treatments for pilots, flight attendants and other such on-board crew affected by jet lag and fatigue.

In another embodiment, the light treatment device can be mounted in the passenger compartments of vehicles, for example, automobiles, transport trucks, buses, trains, and other such vehicles, wherein the device is stored when not in use but readily available to provide a light therapy treatment. In the case of automobiles and trucks, the device may be mounted on the underside of a sun visor, or within the glove compartment, or under the vehicle's dashboard. In the latter two examples, the device can be attached to an adjustable extension arm in order to permit proper positioning for treatment.

The device may also be mounted so as to provide a light treatment for the driver or operator of these vehicles, with appropriate precautions being indicated for safe operation of the vehicle, for example, at those times when the vehicle is parked or idle. One such embodiment is described hereinafter with reference to FIG. 7.

Housing **10** can also be formed to accommodate other electronics, batteries etc. or to define storage space such as for cords, adapters, glasses or other items. The housing can also include a cover or a case. Referring to FIGS. **4** to **6**, a light therapy device according to another embodiment of the present invention is shown. The device has an outer housing including an upper housing member **110** and a lower housing member **112**. The housing members are connected by a hinge **114** that permits them to pivot relative to each other between a closed position shown in FIG. **4** and an open position shown in FIGS. **5** and **6**. When in the closed position, the housing members can be releasably locked together by a catch **116**. The device is small in size and, when closed, resembles a portable compact disc player or a make-up compact.

The housing encloses a light emitting assembly **20**. In the illustrated embodiment, light-emitting assembly **20** is mounted in the upper housing member. The light emitting assembly is mounted on the inwardly facing portion of the upper housing member so that, when the device is in the closed position, assembly **20** is protected within the housing members. In this way, the light emitting assembly, which is more fragile than the housing, is protected against damage during transport.

The device is opened for use to administer a light treatment. In a preferred embodiment, upper housing member **110** unfolds from the closed position by rotating about hinge **114**. Lower housing member **112** acts as a base for supporting the light emitting assembly. Preferably, hinge **114** is of the type that permits self-locking in at least a few rotational orientations. The use of such a hinge permits that, for example, upper housing member can be oriented to direct the light downwardly, horizontally or, if preferred, in other directions. This is useful as it may be necessary, depending on the treatment, to have the light directed into the patient's eyes or alternately downwardly toward a workspace.

Counterweights (not shown) can be mounted in the lower housing member to prevent the device from tipping. Member **112** can also be formed to accommodate electronics, batteries etc. or to define storage space such as for cords, adapters,

5

glasses or other items. Member **112** can also accommodate a treatment calculator, as will be described hereinbelow.

In one embodiment illustrated, for example in FIGS. **1** to **3**, housing **10** also accommodates a calculator including a display **82**, a key pad **84** and a processor mounted within housing **10**. The calculator is programmed to calculate a light treatment regime based on input of information. The calculator processor uses calculation references such as that known as the Jet Lag Calculator™ available from Bio-Brite, Inc., Maryland. In one embodiment, the calculator can be used to calculate light treatment regimes for jet lag based on inputs of information, as follows:

Option 1	
i.	Number of time zones crossed during trip
ii.	Direction of time zones crossed (East or West)
iii.	Normal wake-up time of patient (for establishing the patient's "body clock")
Option 2	
i.	Departure city
ii.	Arrival city
iii.	Normal wake-up time of patient

Based on the input of the above-noted information, the calculator will then calculate and display a treatment regime including, for example, a period of light exposure and a period of light avoidance. In option 2, the calculator determines the number of time zones through which travel will occur and uses this to calculate treatment regime. The calculator in one embodiment calculates a two-day treatment regime.

In one embodiment, the calculator keypad includes keys to be depressed when inputting particular information. As an example, the keypad can include keys such as: "departure city", "destination city" and "wake up time". The calculator can be adapted to prompt the patient such as by displaying questions requesting the appropriate information. Preferably, the calculator includes a pause function capable of recording a time of treatment interruption and capable of outputting from memory the portion of the treatment remaining when treatment is resumed.

In addition or alternately, the calculator can be programmed for calculation of other treatment regimes such as, for example, for treatments to alleviate fatigue in shift workers. Treatments for shift workers may include inputs such as work shift start time, previous shift time and normal waking time.

A speaker **88** is preferably provided for communication to the user. As an example, the speaker can communicate with the calculator processor to audibly prompt a user to input information. In addition, the speaker can function to emit an audible signal, such as an alarm, to alert a user to commence or modify a treatment. In one embodiment, the calculator processor controls a switch for the light emitting assembly such that it is turned on or off in response to a signal from the processor.

In a preferred embodiment, the calculator memory is capable of storing previous treatment regimes. These stored treatment regimes can be recalled from processor memory for repeat trips or shift work schedules.

If desired, to enhance the usefulness of the device, the calculator can also be programmed with other information including a clock, a standard mathematical calculator or other information such as an address book, etc.

6

As noted hereinbefore, a light therapy device according to the present invention can be mounted in a vehicle for use by passengers. One such embodiment is illustrated in FIG. **7**. A vehicle mounting adaptor **50** useful for mounting a light treatment device in a vehicle passenger compartment acts as an interface between the vehicle power port **52** (i.e. an in-dash cigarette lighter) and the light treatment device **54**. In particular, at one end the adaptor has a power port contactor **56** for insertion into the power port. A locking collar **57** is threadedly engaged at the outboard end of the contactor **56**. Once power port contactor **56** is inserted into power port **52**, locking collar **57** can be tightened down about the port by threaded advancement to reinforce the engagement between port **52** and power port contactor **56**.

At the opposite end, the adapter includes a docking port **58** with a recess **59** having therein electrical contactors **60**. The light treatment device is mountable in the recess of docking port **58** in electrical communication with contactors **60**. Venting slots **64** are formed through the docking port and positioned to substantially align with the vents **66** on light treatment device **54** to provide ventilation to the light treatment device therethrough.

Power cables (cannot be seen) extend between ends **56** and **58** to provide electrical communication therebetween. The power cables are housed within a bendable arm **68** of the type including a corrugated tube and internal supports that can be bent into various orientations and, once positioned, will hold fast in that orientation. Arm **68** is bendable yet rigid enough to hold the weight of the light treatment device **54** and docking port **58** without moving out of the bended configuration into which it has been adjusted. Locking collar **57** also securely holds power port contactor **56** in power port **52** even against the weight of the light treatment device and against the stress of bending arm **68**. Adapter **50** can be removed from power port **54** and stored when not required.

Numerous modifications, variations and adaptations may be made to the particular embodiments of the invention described above without departing from the scope of the invention as defined in the claims.

The embodiments of the invention in which an exclusive property or privilege is claimed are defined as follows:

**1.** A method for treating a patient with a light deficient disorder using an ocular light therapy device including:

- an outer housing including an opening, the outer housing including a width, a height and a depth, the width and the height each being greater than the depth and the width and the height defining dimensions of a front face on which the opening is positioned;
  - a support for supporting the housing in a treatment position on a support surface;
  - a light emitting assembly in the housing and operable to emit light through the opening in the housing, the light emitting assembly including an LED light source configured to generate an output of light suitable for ocular light therapy of a light deficient disorder;
  - a diffuser screen of light diffusing sheet material positioned to diffuse light from the LED light source passing through the opening;
  - a treatment selector key on the outer housing for setting a treatment regime; and
  - a processor within the housing for storing the treatment regime and being configured to turn off the light emitting assembly after administering the treatment regime;
- the method comprising:
- operating the ocular light therapy device employing a hand-held operation including:



7

actuating the treatment selector key to emit light from the LED light source of the light emitting assembly through the opening and the diffuser screen according to the treatment regime;

5 setting the ocular light therapy device onto the support surface spaced from the patient in a treatment position supported by the support; and

directing the light toward the eyes of the patient to administer an ocular light treatment until the LED light source is turned off by the processor.

10 2. The method of claim 1 wherein the light emitting assembly includes between about 10 and 150 LEDs.

3. The method of claim 1 wherein the emitted light has an intensity of 50 to 500 candelas.

15 4. The method of claim 1 further comprising pausing and resuming the ocular light treatment.

5. The method of claim 1 wherein the light is administered for  $\frac{1}{4}$  to 4 hours for the ocular light treatment.

6. The method of claim 1 wherein the treatment regime comprises a period of light exposure.

20 7. The method of claim 6 wherein the treatment regime further comprises a period of light avoidance.

8. The method of claim 1 wherein the light therapy device further comprises a memory configured to store the treatment regime.

25

8

9. The method of claim 1 further comprising setting the treatment regime using the treatment selector key.

10. The method of claim 1 wherein the processor is configured to calculate the treatment regime in response to an input from the treatment selector key.

11. The method of claim 10 further comprising setting the treatment regime using the treatment selector key to input to the processor (i) a number of time zones crossed, (ii) a direction of travel and (iii) a normal wake-up time.

12. The method of claim 10 further comprising setting the treatment regime using the treatment selector key to input to the processor (i) a departure city, (ii) an arrival city and (iii) a normal wake-up time.

13. The method of claim 1 wherein the light deficient disorder is a circadian sleep disorder.

14. The method of claim 1 wherein the light deficient disorder is a circadian disruption.

15. The method of claim 1 wherein the light deficient disorder is Seasonal Affective Disorder.

16. The method of claim 1 wherein the light deficient disorder is jet lag.

17. The method of claim 1 wherein the light deficient disorder is bulimia.

18. The method of claim 1 wherein the light deficient disorder is PMS.

\* \* \* \* \*