



US007575572B2

(12) **United States Patent**
Sweeney

(10) **Patent No.:** **US 7,575,572 B2**
(45) **Date of Patent:** **Aug. 18, 2009**

(54) **METHOD AND DEVICE FOR DELIVERING MEDICINE TO BONE**

(75) Inventor: **Patrick J. Sweeney**, Flossmoor, IL (US)

(73) Assignee: **Spinal Generations, LLC**, Olympia Fields, IL (US)

(*) Notice: Subject to any disclaimer, the term of this patent is extended or adjusted under 35 U.S.C. 154(b) by 643 days.

(21) Appl. No.: **10/620,287**

(22) Filed: **Jul. 15, 2003**

(65) **Prior Publication Data**

US 2005/0015059 A1 Jan. 20, 2005

(51) **Int. Cl.**
A61M 5/00 (2006.01)

(52) **U.S. Cl.** **604/264**

(58) **Field of Classification Search** 604/175,
604/264; 606/72-73, 93, 80, 60, 62, 92
See application file for complete search history.

(56) **References Cited**

U.S. PATENT DOCUMENTS

4,399,814 A	8/1983	Pratt, Jr. et al.	
4,653,489 A	3/1987	Tronzo	
4,760,844 A	8/1988	Kyle	
4,976,692 A	12/1990	Atad	
5,047,030 A	9/1991	Draenert	
5,203,770 A *	4/1993	Wigness et al.	604/506
5,425,723 A *	6/1995	Wang	604/523
5,618,286 A	4/1997	Brinker	
5,681,289 A *	10/1997	Wilcox et al.	604/175
5,702,372 A *	12/1997	Nelson	604/264
5,800,407 A	9/1998	Eldor	
5,871,484 A *	2/1999	Spievack et al.	606/60
6,019,761 A	2/2000	Gustilo	
6,048,343 A	4/2000	Mathis et al.	
6,077,265 A	6/2000	Werdning et al.	
6,210,376 B1 *	4/2001	Grayson	604/264
6,214,012 B1	4/2001	Karpman et al.	

6,220,888 B1 *	4/2001	Correa	439/445
6,228,088 B1 *	5/2001	Miller et al.	606/80
6,387,098 B1	5/2002	Cole et al.	
6,679,890 B2	1/2004	Margulies et al.	
2001/0021852 A1 *	9/2001	Chappius	606/73
2002/0138146 A1	9/2002	Jackson	
2003/0045885 A1	3/2003	Margulies et al.	

(Continued)

FOREIGN PATENT DOCUMENTS

WO WO 02/098307 A1 12/2002

OTHER PUBLICATIONS

Office Action for U.S. Appl. No. 10/682,307, mailed Jan. 25, 2007, 7 pages.

(Continued)

Primary Examiner—Nicholas D Lucchesi
Assistant Examiner—Christopher D Koharski
(74) *Attorney, Agent, or Firm*—Foley & Lardner LLP

(57) **ABSTRACT**

Fenestrated bone screws and inserts disposed therein are provided for the delivery of medicants to bone. The bone screws provide a method to strengthen or repair damaged bones, and in conjunction with the inserts, provide a method of delivering a continuous or regulated amount of medicant to a desired location within the bone such as a fracture interface. In one embodiment, the inserts are customized in size, shape, or configuration after the bone screw has been inserted into the patient.

17 Claims, 12 Drawing Sheets

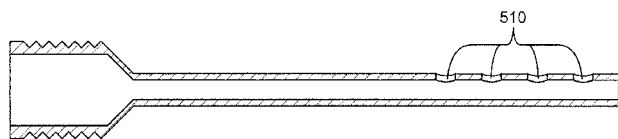
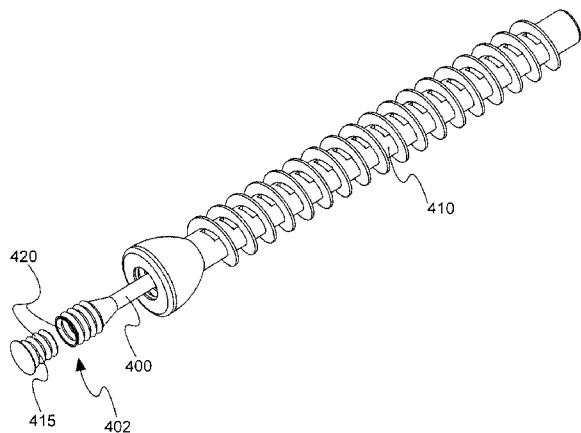

U.S. PATENT DOCUMENTS

2003/0212426 A1 11/2003 Olson, Jr. et al.
2004/0225292 A1* 11/2004 Sasso et al. 606/73
2006/0111767 A1 5/2006 Olson et al.

OTHER PUBLICATIONS

Cecil, M. L. et al., "Projection of the S2 Pedicle Onto the Posterolateral Surface of the Ilium—A Technique for Lag Screw Fixation of Sacral Fractures or Sacroiliac Joint Dislocations," Spine 1996, vol. 21, pp. 875-878; www.kalindra.com/project.htm, 6 pages.

Sato, T. et al., "Calcium Phosphate Augmentation of Screw Fixation in Femoral Neck Fracture," 47th Annual Meeting, Orthopaedic Research Society, Feb. 25-28, 2001, San Francisco, California, 1 page.
Press release from Spine Center Atlanta, "New Screw Debut First-time Use for New Spinal Surgery Device," 2002, Orthopaedic & Spine Surgery of Atlanta LLC; www.SpineCenterAtlanta.com, 2 pages.
Instratek Inc., "Titanium Cannulated Bone Screws Minimize Surgery Time by Eliminating Complicated Procedure Steps," www.instratek.com/bone_screw, 5 pages.
SunMedica—Orthopaedic Surgery Products, "orthoPLUG® Hard Bone Design," Redding, CA 96002; www.sunmedica.com, 1 page.
* cited by examiner

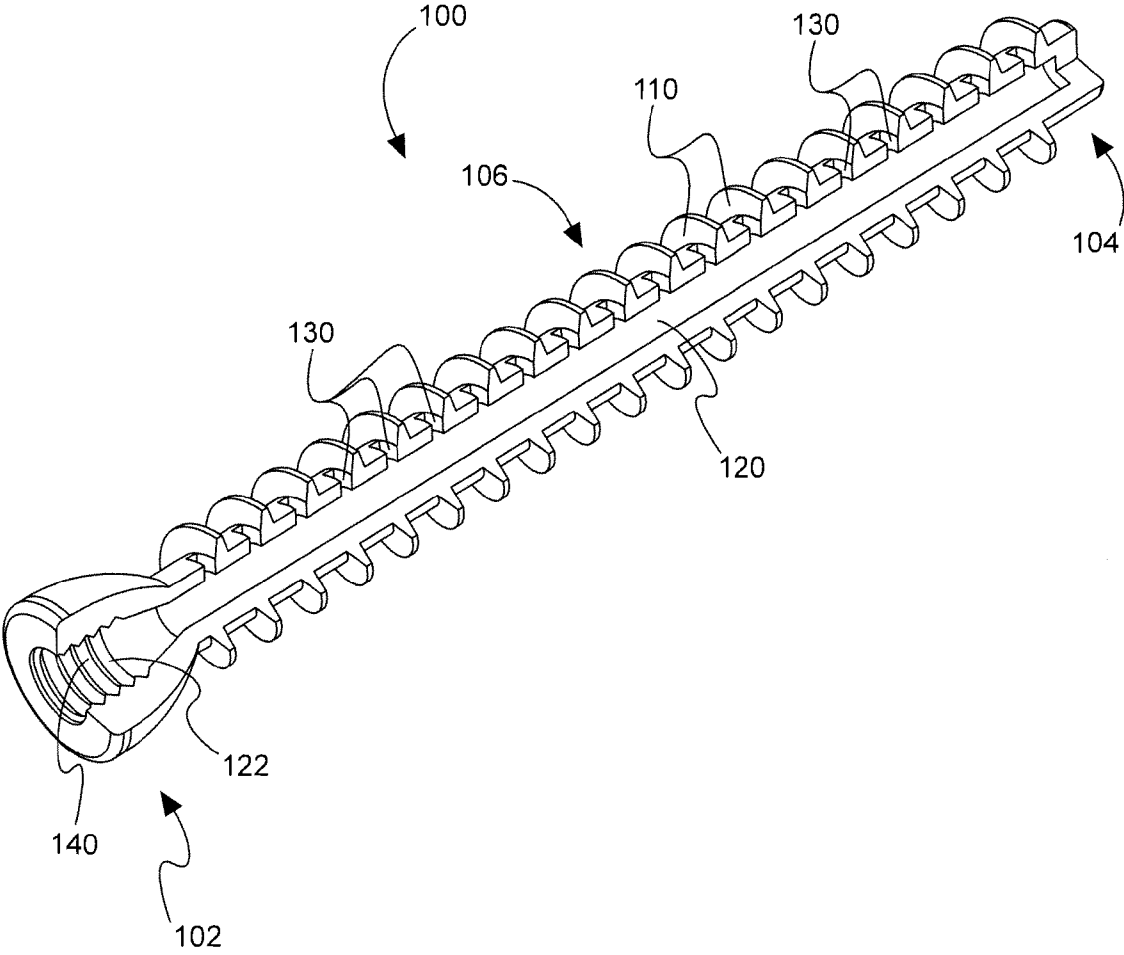

Fig. 1

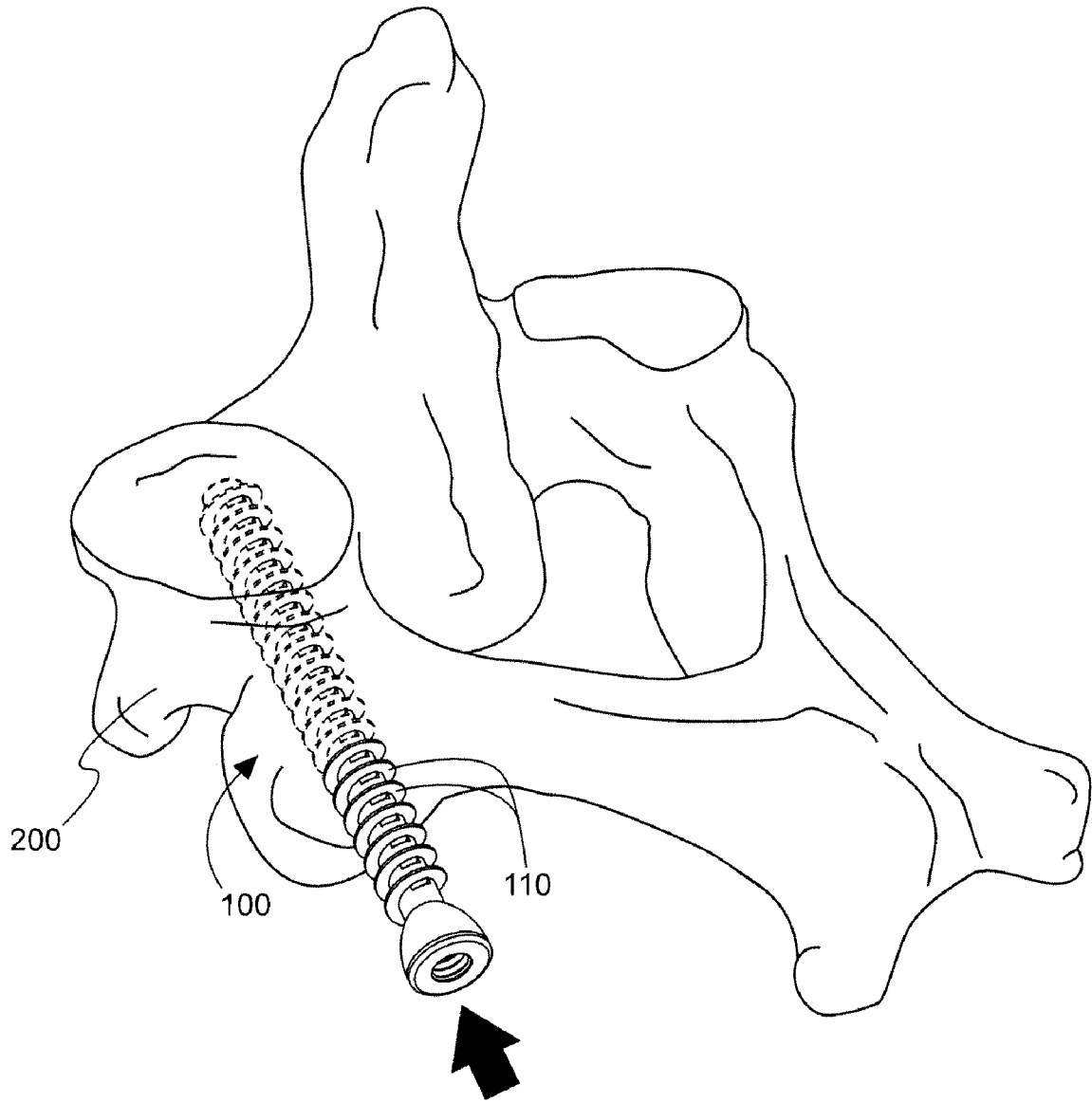

Fig. 2

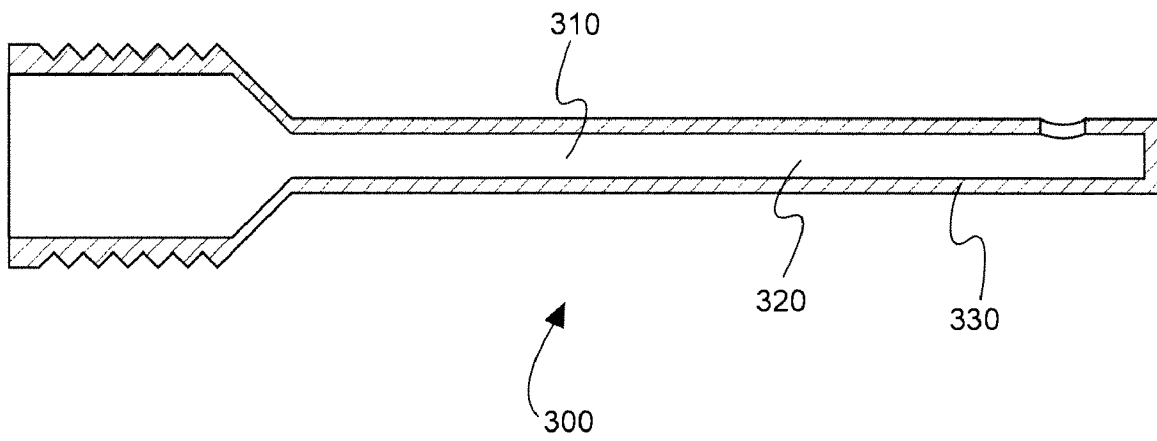

Fig. 3a

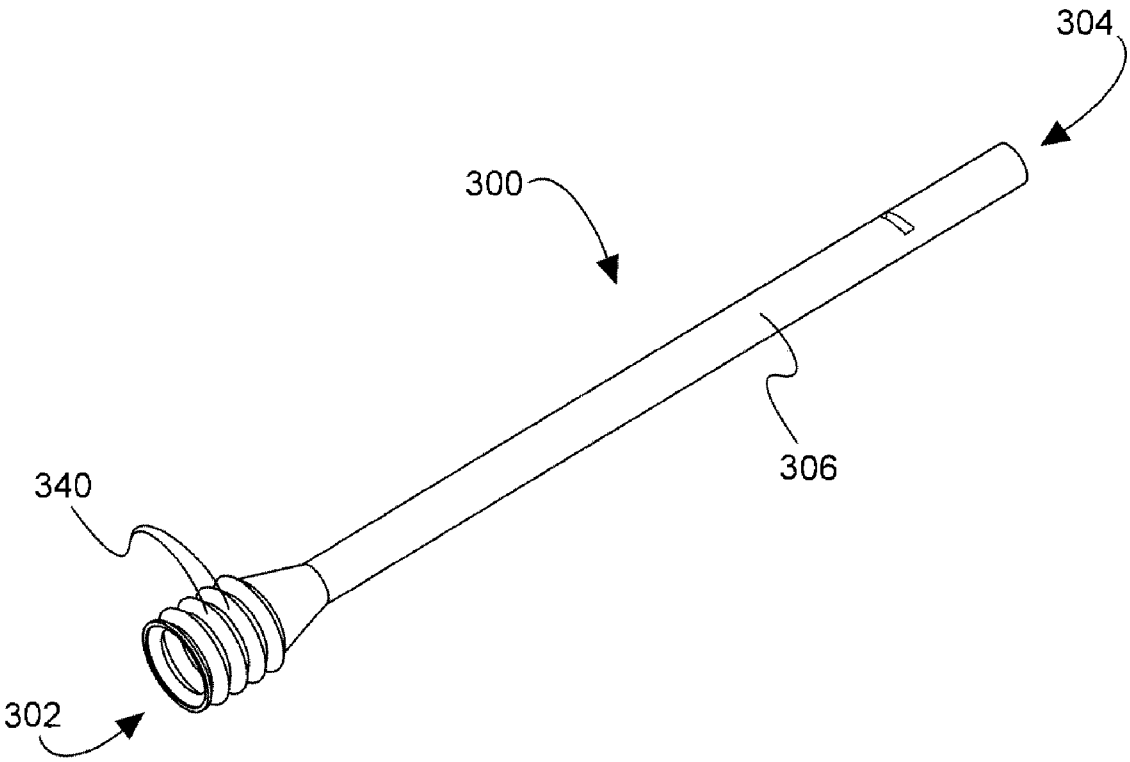

Fig. 3b

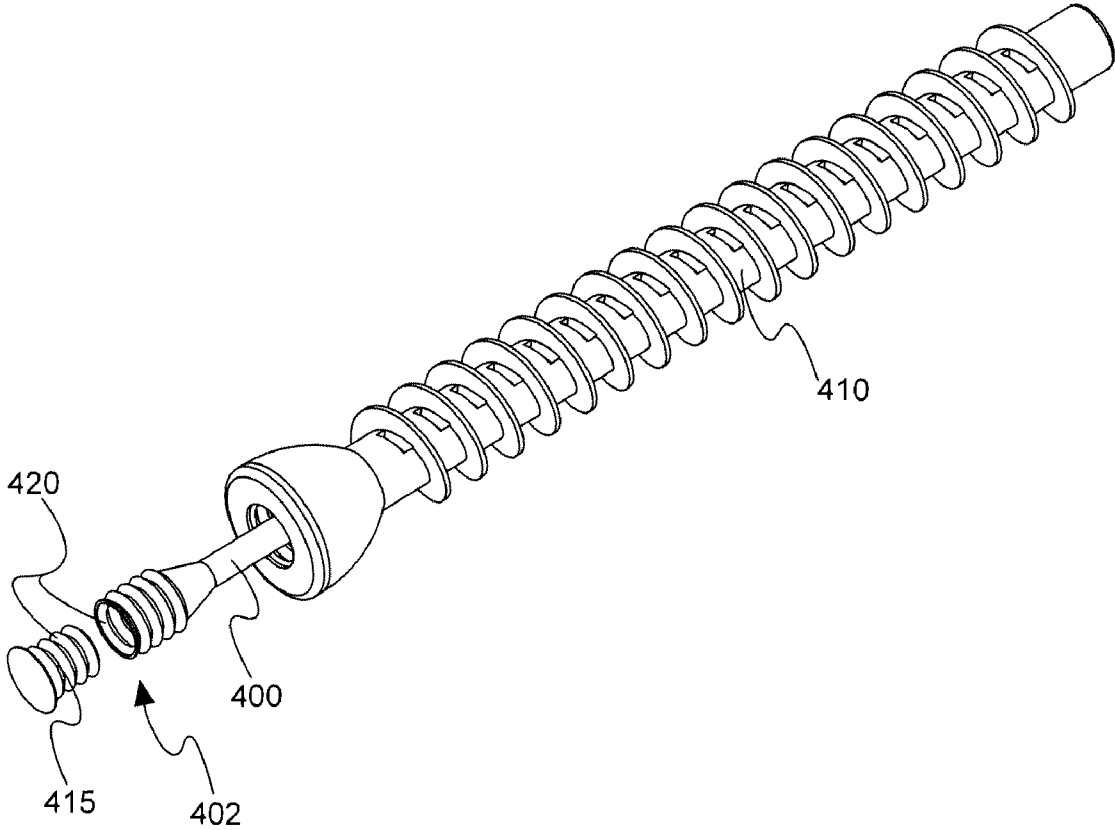

Fig. 4

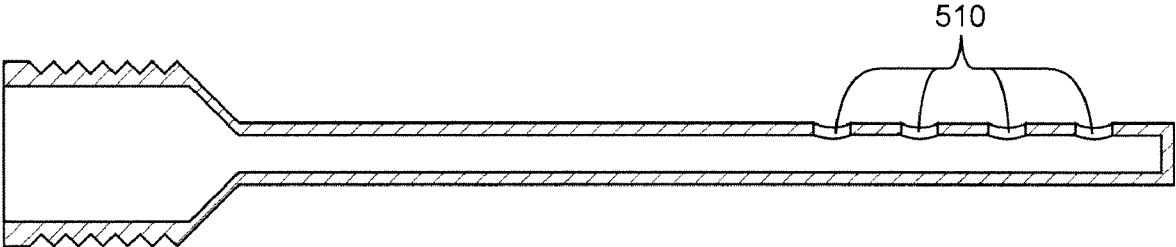

Fig. 5a

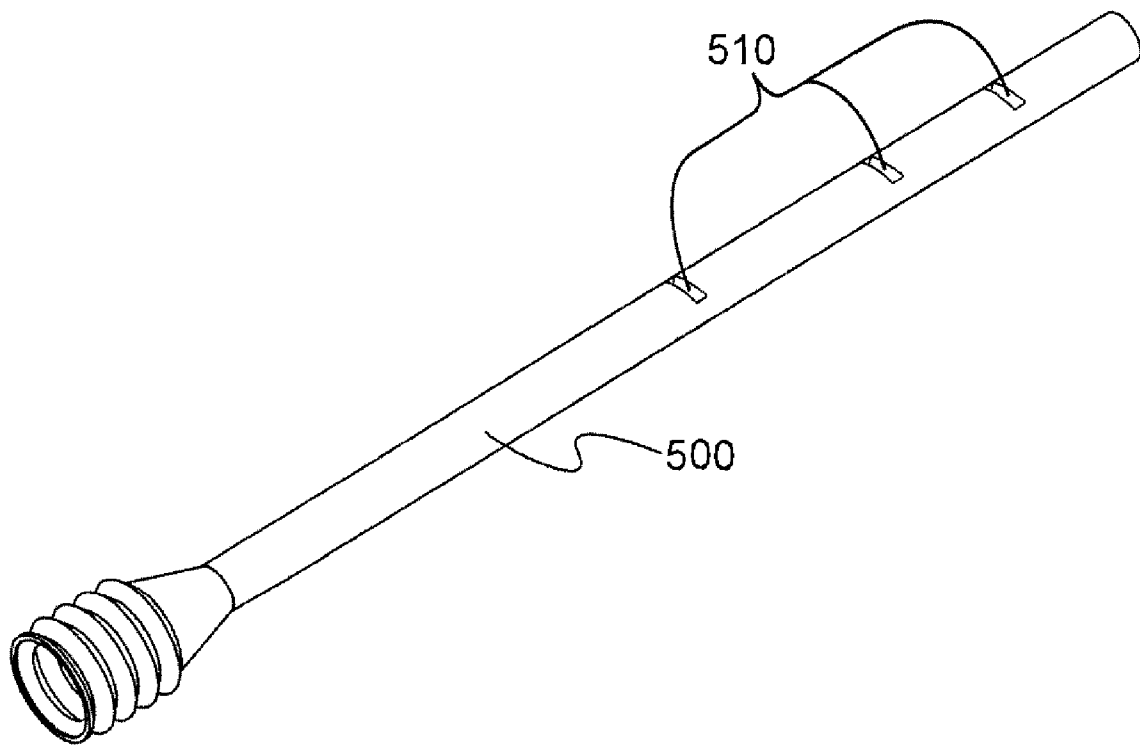

Fig. 5b

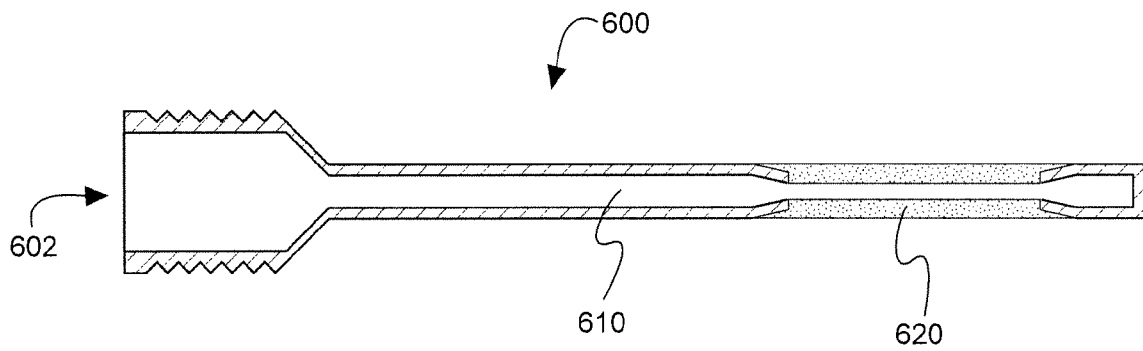

Fig. 6

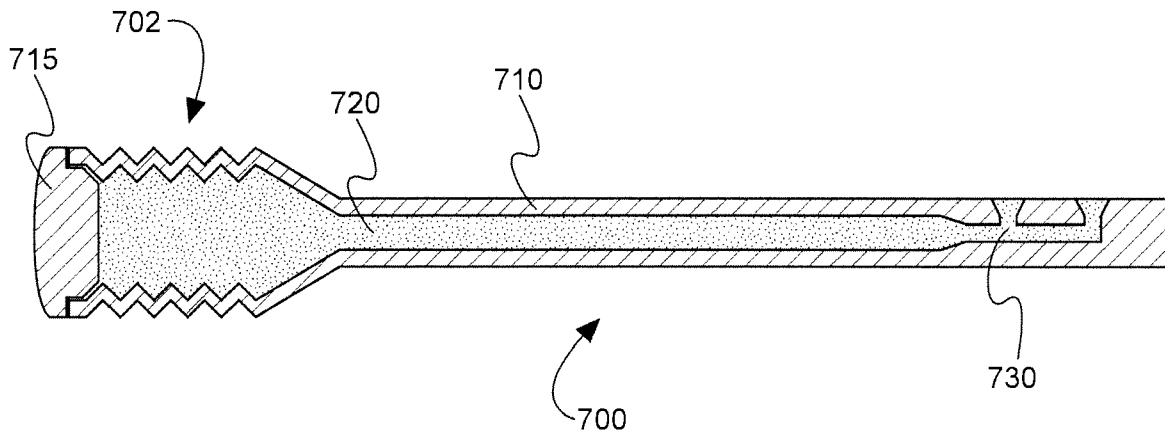

Fig. 7

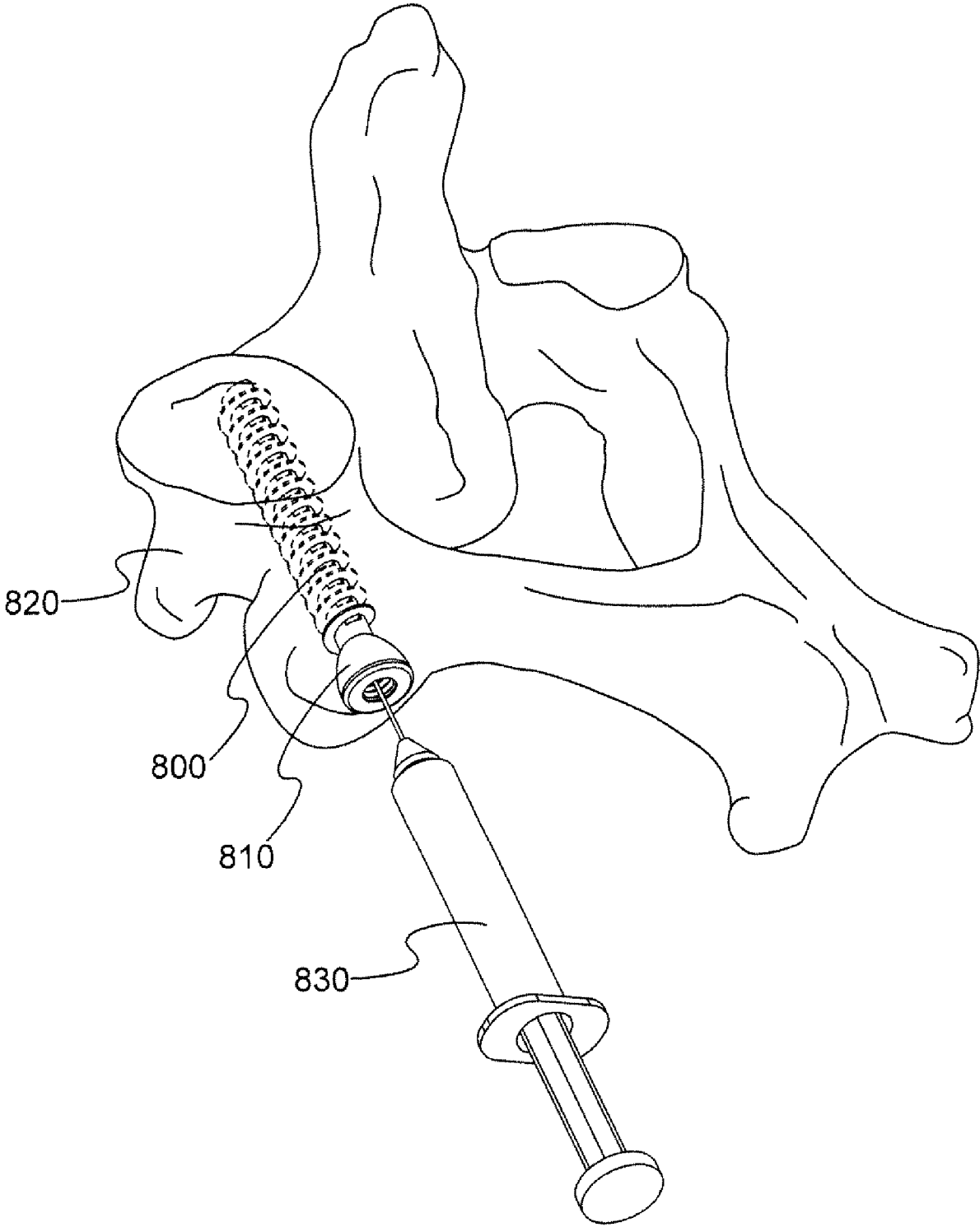

Fig. 8a

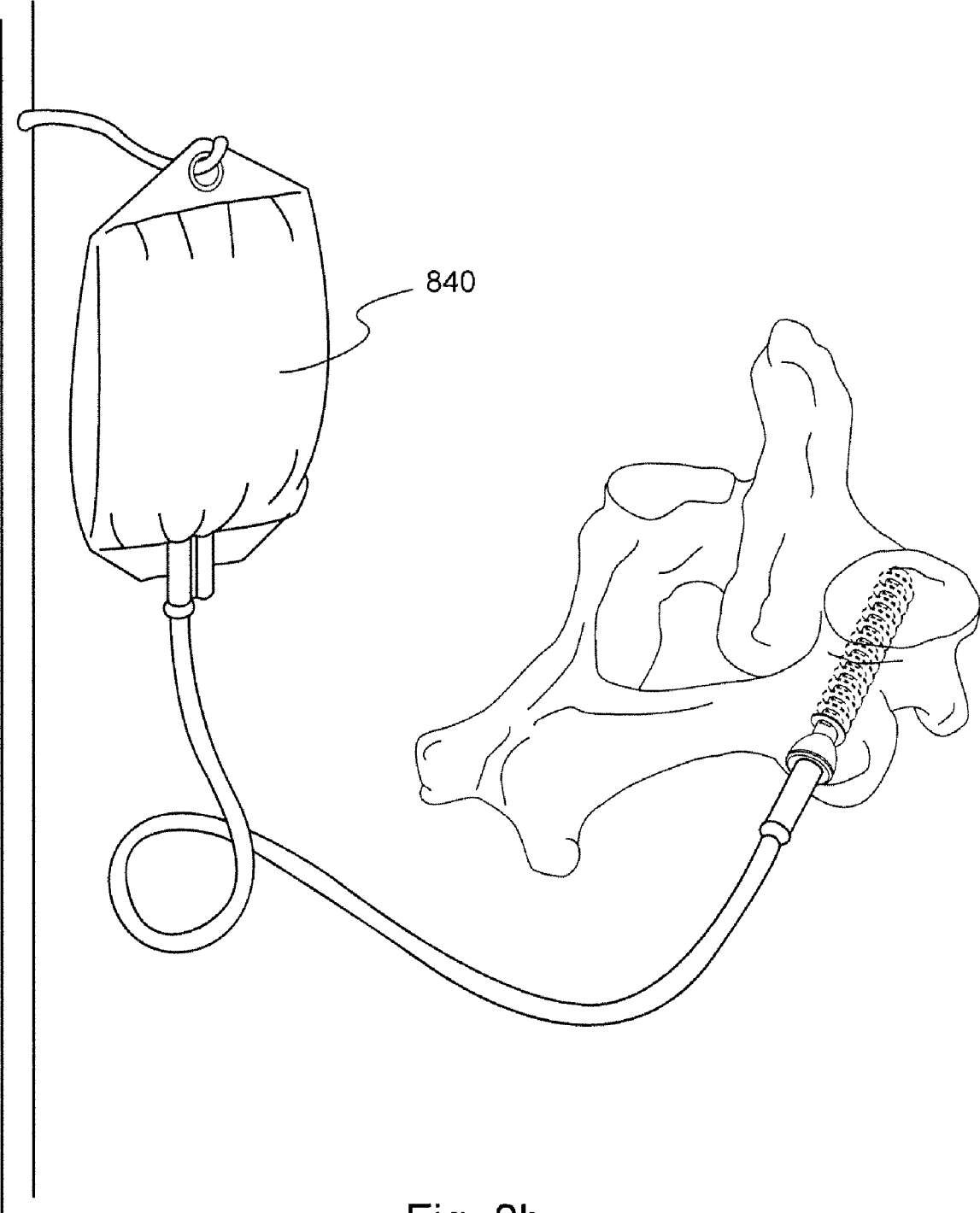

Fig. 8b

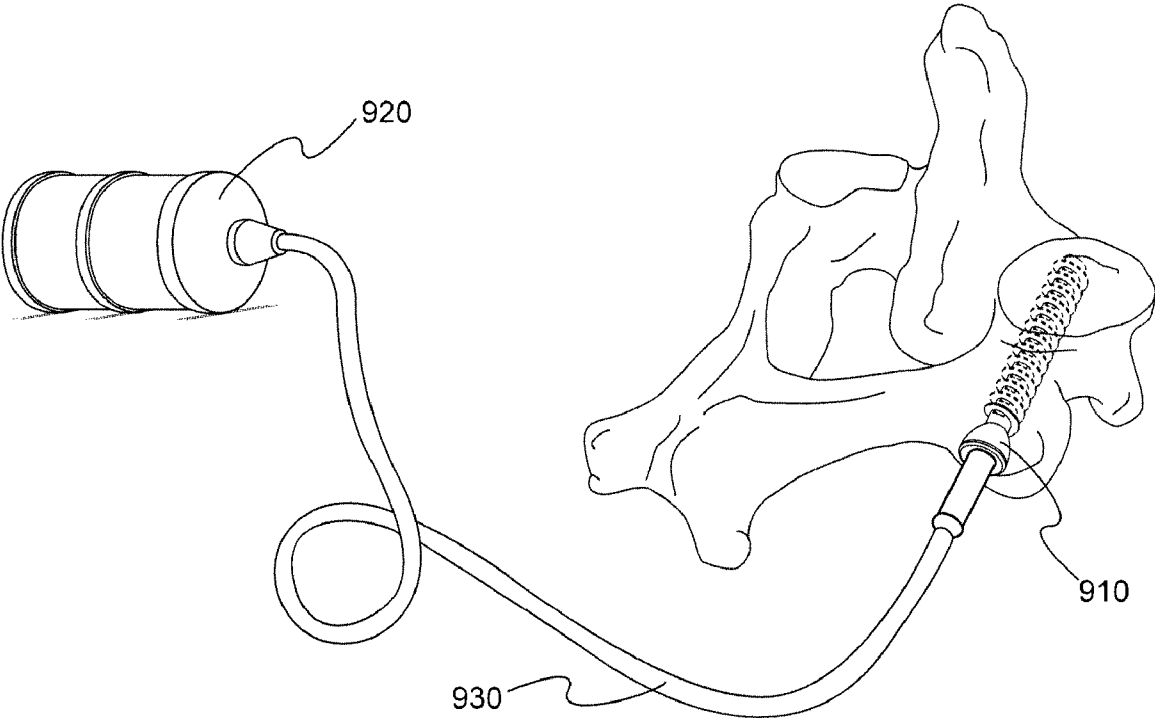

Fig. 9

METHOD AND DEVICE FOR DELIVERING MEDICINE TO BONE

FIELD OF THE INVENTION

The present invention relates to devices and methods for delivering substances such as medicants to bones. More particularly, the present invention concerns devices and methods for delivering substances to the interior or exterior of fractured or otherwise injured bones, especially to the fracture interface thereof.

BACKGROUND OF THE INVENTION

Delivery of medicants or therapeutics to bones is an often desirable but difficult-to-achieve process, especially if one desires to focus the delivery to the interior of a bone or to a particular area in a bone. Delivery pins or needles, such as those disclosed in U.S. Pat. No. 6,210,376, the disclosure of which is hereby incorporated by reference herein, are sometimes used to deliver medication or other fluids into bone. Such pins are typically made of metals such as titanium or steel, and must be fabricated ahead of time for later use. Thus, it is difficult to customize the pins for directing the delivery of medicants or fluids to a specific area of interest within a bone. Moreover, such pins do not serve as fixation screws for holding two or more bones or bone pieces in a fixed spatial relationship with respect to each other.

Bone screws can be used to repair or strengthen fractured or otherwise damaged or diseased bones, often by fixing two or more bones or bone pieces with respect to each other, in which case the bone screw may be referred to as a fixation screw. Such screws have been adapted to deliver liquids such as bone cements to the interior of a bone, and are disclosed in U.S. Pat. Nos. 5,047,030 and 6,214,012, for example, the disclosures of which are hereby incorporated by reference herein. These devices must be fabricated ahead of time for later use, thereby substantially limiting the ability to customize the device to the needs of an individual patient. Moreover, while these devices may be suitable for the one-time delivery of a curable substance such as a bone cement, they provide no way to control or regulate the amount of substance delivered. Substance delivery also cannot be directed to certain areas within the bone and not others without changing the location or configuration of the bone screw itself.

Thus, a need exists for a device capable of delivering a substance to a bone, especially to specific areas within the bone, such as a fracture interface. In addition, a further need exists for the ability to customize the delivery location and amount during the course of an operation, once the bone screw is in place, for example.

SUMMARY OF THE INVENTION

In accordance with the present invention, a bone-screw insert is disposed within a bone screw to provide a device for the delivery of a desired substance to the interior or exterior of a bone or its surrounding tissues. The bone screws and the inserts are cannulated along at least a portion of their lengths. The bone screws are fenestrated and the inserts are either fenestrated or permeable to the substance to be delivered such that when the insert is disposed within the bone screw a delivery pathway exists whereby the substance can be delivered from one end of the insert to the exterior of the bone screw through the bone-screw fenestrations.

In one aspect of the present invention the bone screw comprises a fixation screw whereby two or more bones or bone

pieces may be held in a fixed spatial relationship with respect to each other. It may often be desirable to deliver a substance at or near the fracture interface of a broken bone, for example. In such a case, the desired positions of bone-screw fenestrations which will align with or match this location may not be known until after the bone screw has been disposed within the bone. The bone-screw inserts of the present invention thus allow one to selectively block the bone-screw fenestrations to which substance delivery is not desired, while maintaining a substance delivery pathway to one or more bone-screw fenestrations to which substance delivery is desired.

In another aspect of the invention, the device comprises a reservoir which may serve as a source of the one or more substances to be delivered to the vicinity of a bone. Reservoirs useful in the practice of this invention may comprise the cannulated portions of the bone screw or insert, or they may be reservoirs that are connected to the bone screw or insert for substance delivery. In certain embodiments the present invention may further comprise a pump for facilitating the delivery of the one or more substances to the vicinity of a bone. Such pumps may, for example, aid in the continuous or regulated flow of a fluid into the bone screw or insert for delivery to the desired location.

Yet another aspect of the invention provides a method for administering a substance to a bone. The method comprises introducing a cannulated, fenestrated bone screw into a bone, introducing a cannulated insert into the bone screw, and introducing a substance to be delivered into the cannulated portion of the insert. The method may further comprise the use of a fenestrated or permeable insert, or the use of reservoirs or pumps to aid in substance delivery. In certain embodiments of the invention the insert may initially serve the purpose of preventing bone fragments, blood, fat, or other materials from entering the cannulated portion of the bone screw, especially during insertion of the bone screw into the bone, for example. This may then be followed by readjustment or realignment of the insert to provide a pathway for the substance to be delivered at a later point in time.

BRIEF DESCRIPTION OF THE DRAWINGS

FIG. 1 shows a perspective view of a bone screw in accordance with the present invention.

FIG. 2 shows a bone screw inserted into the hip bone of a patient.

FIG. 3(a) shows a schematic cross-sectional view of a bone-screw insert with a single fenestration.

FIG. 3(b) shows a perspective view of the bone-screw insert of FIG. 3(a).

FIG. 4 shows a perspective view of a bone screw, a bone-screw insert, and an insert cap, in accordance with the present invention.

FIG. 5 shows a schematic cross-sectional view of a bone-screw insert with multiple fenestrations.

FIG. 5(b) shows a perspective view of the bone-screw insert of FIG. 5(a).

FIG. 6 shows a schematic cross-sectional view of a bone-screw insert with a porous section along the length of the shaft.

FIG. 7 shows a schematic cross-sectional view of a bone-screw insert with an internal reservoir and a cap.

FIG. 8(a) shows a perspective view of a syringe being used to provide a liquid to a bone screw disposed in a hip bone.

FIG. 8(b) shows a perspective view of a IV being used to provide a liquid to a bone screw disposed in a hip bone.

FIG. 9 shows a perspective view of a pump assembly being used to provide a liquid to a bone screw disposed in a hip bone.

DETAILED DESCRIPTION OF THE PREFERRED EMBODIMENTS

In accordance with the present invention, a bone-screw-insert is disposed within a fenestrated bone screw, and the combination is used to deliver desired substances to the vicinity of a bone. The bone screw and the insert are cannulated along at least a portion of their lengths. In certain embodiments, the insert may also be fenestrated. The inserts of the present invention may be comprised of a single piece, or alternatively the insert may be comprised of several pieces or sections. In certain embodiments, the bone screw may be a fixation screw used to hold two or more bones or bone pieces in a fixed spatial relationship with respect to each other. The substances to be delivered may comprise medicants or therapeutics, or other substances which are desirable to deliver to the vicinity of a bone. The substance or a combination of substances may be delivered to the interior of the bone, to the exterior of a bone, to the fracture interface between two or more broken bones, or to any other location which may be facilitated by utilization of the present invention.

For the purposes of this invention, the term “cannulated” means that the screw or insert comprises a hollow cavity disposed inside at least part of its shaft. For example, the cavity may consist of a bore beginning at or near one end of the screw or insert and extending longitudinally into the screw or insert. Other configurations are possible, however, and the hollow cavity need not be restricted to a cylindrical shape or a circular cross-section. The cavity may extend throughout the entire length of the screw or insert, thus creating openings at each end of the screw or insert, or alternatively, the cavity may extend only partially into the interior of the screw or insert. The shape and size of the cavity may be suitably chosen to allow delivery of the desired substance through the screw or insert to the bone area of interest. When it is desired to use the cannulated portion of the screw or insert as reservoir for the substance to be delivered, for example, the cavity may be made as large as possible so long as the screw and insert maintain the structural integrity needed for introduction into the bone.

For the purposes of this invention, the term “fenestration” is used broadly to include any slot, gap, or perforation that defines an opening between the inside of the cannulated portion of the screw or insert to the outside of the screw or insert whereby a desired substance may be delivered. Thus, a fenestrated screw comprises an opening which defines a substance delivery pathway between the internal cannulated portion and the exterior of the screw. Likewise, a fenestrated insert is one that comprises an opening which defines a substance delivery pathway between the internal cannulated portion and the exterior of the insert. In certain embodiments of the present invention where a fenestrated insert is utilized in combination with a fenestrated screw, at least one screw fenestration and at least one insert fenestration may be designed to align with each other once the screw and insert are in their appropriate configuration and position. Alignment or coordination of an insert fenestration and a screw fenestration will define a substance delivery pathway between the internal cannulated portion of the insert and the exterior of the screw.

In accordance with the present invention, fenestrations will typically extend in the radial direction from the internal cannulation to the exterior of the screw or insert, but other configurations are possible. Such fenestrations are separate and

distinct from the opening at or near the one end of the screw or insert created by the cannulation. Further in accordance with the present invention, the fenestrations may be any desired shape or size desired to effect the delivery of the desired substance. For example, the fenestration cross-sections may be round, oval, or square. The fenestration cross-sections may, if desired, change shape between the inside and the outside of the screw or insert. Any number or combination of fenestrations may be located along the shaft or at the ends of the screws and inserts of the present invention. The insert fenestrations may be larger or smaller than the screw fenestrations.

For the purposes of this invention, the term “bone screw” is intended to refer to screws of all types which are presently known or hereafter devised for implantation into bone. In this regard, cancellous screws, cortical screws, and machine screws are all contemplated as being within the scope of the types of screws useful in the practice of the present invention. The bone screws of the present invention will typically comprise threads along at least a portion of the exterior of the screw shaft, but it should be appreciated that tacks, pins, nails and the like may also be included within the definition of a bone screw for the purposes of the present invention, whether threaded or unthreaded. When threads are present, it may be found advantageous to use self-tapping threads, or alternatively, the threads can be pre-cut in the bone prior to bone-screw insertion.

Referring now to FIG. 1, there is disclosed a bone screw **100** having two ends **102** and **104** connected by a shaft **106**, and bone screw threads **110**. The cut-out of FIG. 1 reveals that bone screw **100** comprises a cannulated portion **120**, and bone screw fenestrations **130** along the length of the cannulated portion **120**. It will be appreciated by one skilled in the art that the fenestrations **130** need not be even spaced along the cannulated portion **120**, but may be arranged in a desired pattern or frequency along the length of the cannulated portion **120**. It will be further appreciated by one skilled in the art that one end **122** of the cannulated portion **120** of the bone screw **100** is configured to accept a bone screw insert. For example, the bone screw **100** may comprise additional threads **140** on the one end **122** of the cannulated portion **120** to promote fixation of a bone screw insert.

In one embodiment of the current invention the bone screw may be a fixation screw used to hold two or more bones or bone pieces in a fixed spatial relationship with respect to each other. Fixation screws are known in the art. One such device is disclosed by Tronzo, U.S. Pat. No. 4,653,489, the disclosure of which is hereby incorporated by reference herein. In accordance with the present invention, the bone screw may be used to mend peripheral skeletal fractures or osteotomies, repair a spondyloysis or an odontoid fracture, or fuse lumbar facet joints, for example. Other beneficial uses of bone screws, and more particularly, fixation screws, will be known to one skilled in the art and are to be included within the scope of the present invention.

Referring now to FIG. 2, there is disclosed a bone screw **100** disposed partially within a bone **200**. Bone **200** may, for example, represent a human hip bone. In one embodiment, bone screw **100** is disposed within bone **200** by rotating the bone screw **100** such that the bone screw threads **110** act to pull bone screw **100** into bone **200**, thereby anchoring bone screw **100** into place.

Bone screws of the present invention may comprise any material suitable for placement into a bone without harmful effects on the patient. Examples of suitable materials include, but are not limited to, titanium and its alloys, tantalum and its alloys, nickel-cadmium and its alloys, steel and its alloys,

5

plastics, absorbable materials, resorbable materials, polyamino acids, polylactide, polyglycolide, hydroxylapatite, and tricalciumphosphate. Other materials useful for bone screw construction will be known to those skilled in the art, and are to be included within the scope of the present invention.

The device of the present invention further comprises a bone-screw insert. For the purposes of this invention, the term “insert” is used to refer to one or more cannulated members which are disposed within the cannulated portion of a bone screw. Referring now to FIG. 3(a), the insert 300 comprises a cannulated portion 310 which consists of a hollow cavity 320 surrounded by the insert wall 330, where the cavity and wall dimensions may be suitably chosen in order to carry out the practice of the invention disclosed herewith. In certain embodiments, the insert may comprise a single piece, as disclosed in FIG. 3(a). Alternatively, the insert may comprise two or more pieces or sections that, when taken together, form the insert of the present invention. Referring now to FIG. 3(b), when the insert 300 is a single piece, the insert comprises two ends, 302 and 304, connected by a shaft 306. The shaft may be cannulated along its entire length, creating openings at each end of the insert. Alternatively, the cannulation may extend only partially into the shaft so long as the cannulation is sufficient to allow for delivery of a substance from one end of the insert to one or more bone-screw fenestrations. One end 302 of the insert 300 may comprise threads 340 which interlock with bone screw threads 140 of FIG. 1 to help fix an insert 300 into a bone screw 100. When the insert comprises two or more pieces or sections, only one of the sections need be cannulated such that the insert sections, when taken together, allow for delivery of a substance from one end of the insert to one or more bone-screw fenestrations.

In one embodiment of the present invention, the exterior dimensions of the insert are only slightly smaller than the interior dimensions of a cannulated bone screw to provide for a tight but sliding fit when the insert is placed into the bone screw, as depicted in FIG. 4 in which an insert 400 is shown partially disposed within a bone screw 410. Also disclosed in FIG. 4 is an insert cap 415 which can be used to substantially seal the one end 402 of the insert 400 via insert cap threads 420 either before, during, or after the bone screw 410 and insert 400 are put into place. The insert may have substantially the same cross-sectional shape as the cannulated portion of the bone screw, or their cross-sectional shapes may be different. For example, the internal bone screw cavity and the exterior surface of the insert may have a substantially circular cross-section. One advantage of this embodiment is that after the insert has been disposed within the bone screw, the insert may be rotated with respect to the screw to achieve alignment of certain of the insert and bone-screw fenestrations, for example. In another embodiment, the insert and bone screw may have substantially non-circular cross-sections such that the insert is not free to rotate once it has been disposed within the bone screw. In yet another embodiment, at least part of the insert cross-section may not match that of the bone screw cavity such that when the insert is disposed within the bone screw, one or more channels are formed longitudinally along at least part of the insert and bone screw shafts. Such channels may be useful, for example, to allow air or fluids to escape the bone screw cavity as the insert is introduced.

When substantially unimpeded delivery of a substance to one or more bone-screw fenestrations is desired, the inserts of the present invention may comprise one or more insert fenestrations 510, as depicted in FIG. 5(a). An insert having an appropriate number, size, shape, and location of insert fenestrations can be chosen by the practitioner without undue

6

experimentation to provide a delivery pathway between at least one end of the insert and the one or more bone-screw fenestrations. For example, FIG. 5(b) discloses an insert 500 comprising a plurality of insert fenestrations 510 having a substantially rectangular cross-section. Alternatively, the delivery pathway may initiate at one end of the bone screw and pass through the insert to one or more bone-screw fenestrations. The insert fenestrations need not match the bone-screw fenestrations in number, size, shape, or location, although it may be advantageous to locate at least one of the insert fenestrations such that it may be substantially aligned with at least one bone-screw fenestrations once both the bone screw and the insert are in place.

In another embodiment of the present invention, the inserts of the present invention may be permeable to the substance to be delivered such that the substance is delivered to the exterior of the insert by diffusion through the insert wall or through small openings in the insert wall. Such openings may be intentionally created such as by increasing the porosity of the insert material (e.g., by introducing a series of pinpricks into the material), or they may exist naturally as pores in the material. Referring to FIG. 6, there is disclosed an insert 600 comprising a cannulated portion 610 and a permeable material 620 wherein a substance to be delivered can travel from one end 602 of the insert to the permeable material 620. When the insert comprises a material that is at least partially permeable to the substance to be delivered, the insert may or may not be fenestrated so long as delivery of the desired substance is not completely impeded by the insert. An embodiment of the present invention comprising a permeable but non-fenestrated insert may be preferred when it is desired to effect a controlled, slow release of the desired substance to a bone, or when it is desired to prevent bone fragments, blood, fat or other materials or fluids from traveling from the exterior of the insert to the interior cavity.

When it is desired to use the cannulated portion of the insert as a reservoir for the substance to be delivered, or when the substance is to be delivered to a bone by permeation through the insert walls, it may be desirable to make the insert walls as thin as possible. Referring now to FIG. 7, there is disclosed an insert 700 with walls 710 surrounding a reservoir 720. One end 702 of the insert may be substantially sealed by insert cap 715. For example, in one embodiment, the insert may comprise a thin-walled tube which increases the available volume for storage of the substance, and which also increases the diffusion of the substance through the insert wall. In another embodiment, the insert may comprise a film or coating on the interior surfaces of the bone-screw cavity. Inserts in accordance with this embodiment may be as thin as a few hundred nanometers or less, which again may be beneficial for increasing the reservoir size with the bone screw and insert cavity, and for increasing the diffusion of the substance through the insert wall.

In another aspect of the present invention, the delivery of a substance to a bone may alternately be controlled or directed by diminishing the cavity size within the insert so that the movement of the substance is restricted. In this embodiment, it may be desired that the insert cannulation or insert fenestrations be a few microns (e.g., 5 microns) or less in size. Referring again to FIG. 7, there is further disclosed a cannulated portion 730 of insert 700 which is diminished in size so as to restrict or limit the flow of a substance from the reservoir 720. The exact configuration and geometry of an insert providing the desired level of substance delivery can be determined by one skilled in the art without undue experimentation, and all such configurations are to be included within the scope of the present invention.

In yet another aspect of the present invention, the inserts may control or direct the delivery of a substance to a bone through a fenestrated bone screw by substantially blocking one or more of the bone-screw fenestrations. This approach may be advantageous when it is desired to deliver the substance to a specific location with respect to the bone screw's position within the bone. Since the exact bone-screw fenestrations which align with or match this location may not be known until after the bone screw has been disposed within the bone, the bone screw inserts of the present invention allow one to selectively block the bone-screw fenestrations to which substance delivery is not desired, while maintaining a substance delivery pathway to one or more bone-screw fenestrations to which substance delivery is desired. Moreover, by utilizing an insert whereby the insert fenestrations align with the bone-screw fenestrations to which substance delivery is desired, one may achieve substantially unimpeded delivery of the substance to the area of interest.

In addition, the bone-screw inserts of the present invention, even when fenestrated, may be advantageously used to significantly hinder bone fragments, blood, fat, or other materials from entering the cannulated portion of the bone screw, especially during insertion of the bone screw into the bone, for example. In this case it may be desirable to initially position the insert and bone screw such that the insert fenestrations do not align with the bone-screw fenestrations. The insert may then be subsequently re-positioned at a later time to align one or more of the insert fenestrations with the bone-screw fenestrations to facilitate substance delivery.

Inserts of the present invention may comprise any material compatible with the bone screw and able to be placed within the bone screw without producing adverse effects to the patient. Examples of suitable insert materials include, but are not limited to, titanium and its alloys, tantalum and its alloys, nickel-cadmium and its alloys, steel and its alloys, plastics, absorbable materials, resorbable materials, polyamino acids, polylactide, polyglycolide, hydroxylapatite, and tricalcium-phosphate. Other materials useful for insert construction will be known to those skilled in the art, and are to be included within the scope of the present invention. When the insert comprises two or more sections, the sections need not comprise the same material. In addition, when it is desired that the insert be permeable to the substance to be delivered, one or more of the insert sections may comprise a material specifically chosen to impart the desired level of permeability to the insert.

The insert may be sold or otherwise provided in a kit containing two or more inserts having different fenestrations or permeability characteristics. The availability of such a kit has the advantage of allowing a practitioner to select an appropriate insert based on the particular needs of the patient.

In accordance with the present invention, the insert is disposed within the bone screw to provide for a directed or controlled delivery of a desired substance to a bone. For the purposes of this invention, the term "substance" is used to refer to one or more chemical compounds that are useful when delivered to the vicinity of a bone. Substances may be chosen to help treat diseased bone as well as fractured or otherwise injured bones. Alternatively, the substance may be delivered to otherwise healthy bone to help maintain overall bone health, for example. Representative example substances include medicants or therapeutics such as antibiotics, chemotherapeutics, angiogenic factors, bone morphogenic proteins, and bone growth factors. Other desirable substances may be known or hereinafter determined by one skilled in the art, which are to be included within the scope of this invention.

In certain applications of the present invention it may be desirable that the substance be stored in a reservoir prior to delivery to a bone. Thus, it may be advantageous for the device of the present invention to further comprise a reservoir.

For the purposes of this invention, the term "reservoir" refers to any source of the one or more substances to be delivered to the vicinity of a bone. For example, the reservoir may comprise the hollow cavity created by the cannulation of the bone-screw insert and any part of the bone-screw cannulation not occupied by the insert, as depicted in FIG. 7 and described above. In one embodiment of the present invention, the substance to be delivered may be absorbed into a sponge-like material such as a collagen, for example, which may then be disposed within the cannulated portion of the bone screw or insert, or both. When additional reservoir space is desired, a suitable reservoir may be connected to the cannula opening of either the bone screw or insert. For example, FIG. 8(a) discloses a bone screw **800** and an insert **810** disposed therein, both of which are disposed within a bone **820**. FIG. 8(a) further discloses a syringe **830** which acts as a reservoir in accordance with the present invention to provide a substance to the bone **820** via bone screw **800** and insert **810**. Another embodiment of the present invention, is depicted in FIG. 8(b) which discloses an IV **840** which serves as a reservoir for delivering a substance to a bone via a bone screw and an insert. In yet another embodiment of the present invention, the reservoir may be implanted beneath the patient's skin, i.e., subcutaneously.

In another aspect of the present invention, it may be advantageous for the device of the present invention to further include a pump **920**, as depicted in FIG. 9, for delivering a substance to a bone via a bone screw and an insert **910**, and tubing **930**. A pump may be utilized to aid in delivery of the substance to the vicinity of a bone by, for example, delivering a continuous, regulated volume to the screw. The pump may also be used to increase the fluid pressure within the cannulated portion of the insert, thereby aiding fluid flow through the insert fenestrations or insert walls, for example. This embodiment may have the further advantage that the positive pressure created by the pump within the cannulated portion of the insert or bone screw hampers the influx of unwanted materials or compounds into the device. The pump may be connected to the cannulated portion of the bone screw or insert as depicted in FIG. 9, and the pump may also be implanted subcutaneously if desired. Examples of pumps which may be suitably used in the practice of the current invention are the implantable pumps disclosed in U.S. Pat. No. 4,588,394, for example. Other examples may be relatively simple pumps such as external pumps similar to those used with patient controlled anesthesia machines or simple IV pumps. These and other pump types and designs which may be currently known or hereinafter discerned by one skilled in the art are to be included within the scope of this invention.

Another aspect of the present invention is a method of administering a substance to a bone. The method comprises introducing a cannulated, fenestrated bone screw into a bone, introducing a cannulated insert into the bone screw, and introducing a substance to be delivered into the cannulated portion of the insert. Under some circumstances, one may find it advantageous to introduce the insert into the bone screw, in its entirety or only partially, prior to introducing the bone screw into the bone. This sequence might be preferred in order to shorten the overall surgery time, or to reduce the amount of material that enters the bone-screw fenestrations from outside the screw during screw insertion, for example. Alternately, other circumstances may make it more advantageous to intro-

duce the insert into the bone screw, in its entirety or only partially, after the bone screw is introduced into the bone. This latter sequence might be preferred in order to be able to determine which screw fenestrations are located at the optimum location for delivery of the desired substance, and thus what insert configuration or length should be used to facilitate substance delivery to those bone-screw fenestrations and not others. Other sequences can be envisioned by one skilled in the art, such as for example, partially introducing the bone screw into a bone, partially or completely inserting the insert into the bone screw, and then completing the insertion of the bone screw into the bone. Even more sequence variations are possible when one considers the additional step of introducing the substance into the cannulated portion of the bone screw insert, and all such sequence variations are to be included within the scope of this disclosure.

In practicing the current invention it may also be found advantageous to drill a pilot hole in the one or more bones or bone pieces in order to facilitate introduction of the bone screw. In this regard it may be found advantageous to use bone screws with self-tapping threads, or to pre-cut the threads in the bone prior to bone screw insertion.

When the bone screw is a fixation screw, the present invention may further comprise the method of holding or fixing two or more bones or bone pieces in a fixed spatial relationship with respect to each other. Such a method may be desirable when it is desired to deliver a substance such as a medicant or therapeutic to the vicinity of a site where a peripheral skeletal fracture or an osteotomy is mended, a spondyloysis or an odontoid fracture repaired, or lumbar facet joints are fused.

The present invention may further comprise the method of delivering a substance to the vicinity of a bone including the steps of attaching a reservoir, a pump, or both, to the bone screws or bone-screw inserts disclosed herein. Such reservoirs and pumps may aid in the continuous, regulated, or long-term delivery of the desired substance to the vicinity of a bone, thereby facilitating the healing process or the overall health of the bone and its surrounding tissues.

What is claimed is:

1. A device for delivering a substance to a bone, the device comprising:

- (a) a bone screw comprising two ends connected by a shaft, wherein the shaft is cannulated along at least a portion of its length;
- (b) one or more bone-screw fenestrations disposed along the cannulated portion of the bone-screw shaft;
- (c) an insert disposed inside the cannulated bone-screw shaft, wherein the insert comprises two ends connected by a shaft and is cannulated along at least a portion of its length; and
- (d) one or more insert fenestrations disposed along the cannulated portion of the insert between the two ends of the insert, wherein the insert is movable between:
 - a first position wherein none of the one or more insert fenestrations align with the one or more bone-screw fenestrations such that at least a portion of the shaft of the insert substantially prevents material from entering the cannulated portion of the bone-screw through the one or more bone-screw fenestrations; and
 - a second position wherein the insert provides a delivery pathway for the substance between at least one end of the bone screw and the at least one bone-screw fenestration.

2. The device of claim 1 wherein at least one insert fenestration aligns with at least one bone-screw fenestration in the second position.

3. The device of claim 1 wherein the insert is rigid.

4. The device of claim 1 wherein the cannulated portion of the bone-screw shaft extends through the entire length of the bone screw.

5. The device of claim 1 wherein the bone screw is a fixation screw.

6. The device of claim 1 wherein one end of the bone screw is self-tapping.

7. The device of claim 1 wherein the bone screw comprises a material selected from the group consisting of titanium and its alloys, tantalum and its alloys, nickel-cadmium and its alloys, steel and its alloys, plastics, absorbable materials, resorbable materials, polyamino acids, polylactide, polyglycolide, hydroxylapatite, and tricalciumphosphate.

8. The device of claim 1 wherein the insert comprises a material selected from the group consisting of titanium and its alloys, tantalum and its alloys, nickel-cadmium and its alloys, steel and its alloys, plastics, absorbable materials, resorbable materials, polyamino acids, polylactide, polyglycolide, hydroxylapatite, and tricalciumphosphate.

9. The device of claim 1 further comprising a substance reservoir attached to at least one end of the bone screw.

10. The device of claim 9 wherein the reservoir is implanted subcutaneously.

11. The device of claim 1 further comprising a pump attached to at least one end of the bone screw.

12. The device of claim 11 wherein the pump is implanted subcutaneously.

13. A device for delivering a substance to a bone, the device comprising:

- (a) a bone screw comprising two ends connected by a shaft, wherein the shaft is cannulated along at least a portion of its length;
- (b) one or more bone-screw fenestrations disposed along the cannulated portion of the bone-screw shaft; and
- (c) an insert disposed inside the cannulated bone-screw shaft such that at least a portion of the shaft of the insert prevents at least some material from entering the cannulated portion of the bone screw through all of the one or more bone-screw fenestrations, wherein the insert comprises two ends connected by a shaft and is cannulated along at least a portion of its length, and further wherein the insert comprises a section between the two ends of the insert that is permeable to the substance to be delivered to the bone.

14. The device of claim 13 wherein the insert further comprises at least one insert fenestration disposed along the cannulated portion of the insert.

15. The device of claim 13 wherein the cannulated portion of the bone-screw shaft extends through the entire length of the bone screw.

16. The device of claim 13 wherein the bone screw is a fixation screw.

17. The device of claim 13 wherein one end of the bone screw is self-tapping.

UNITED STATES PATENT AND TRADEMARK OFFICE
CERTIFICATE OF CORRECTION

PATENT NO. : 7,575,572 B2
APPLICATION NO. : 10/620287
DATED : August 18, 2009
INVENTOR(S) : Sweeney

Page 1 of 1

It is certified that error appears in the above-identified patent and that said Letters Patent is hereby corrected as shown below:

On the Title page,

[*] Notice: Subject to any disclaimer, the term of this patent is extended or adjusted under 35 USC 154(b) by 643 days.

Delete the phrase "by 643 days" and insert -- by 1022 days --

Signed and Sealed this

Eighteenth Day of May, 2010

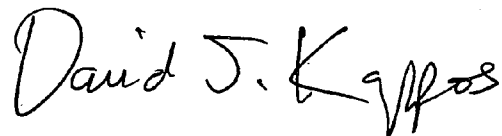
A handwritten signature in black ink that reads "David J. Kappos". The signature is written in a cursive style with a large, stylized 'D' and 'K'.

David J. Kappos
Director of the United States Patent and Trademark Office